

High Voltage Power Supply SHQ HIGH PRECISION series with RS232 Interface

Operator Manual

Contents:

1. General information
 2. Technical Data
 3. SHQ Description
 4. Front panel
 5. Operation
 6. RS232 Interface
 7. Program example
- Appendix A: Block diagram

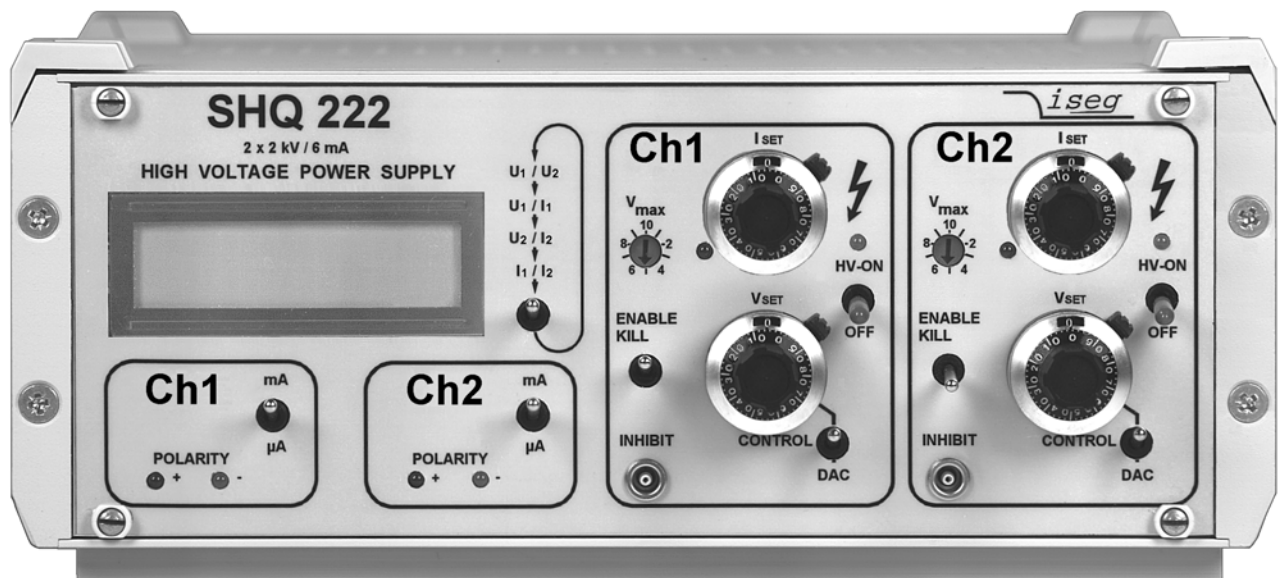

WARNING!

-It is not allowed to use the unit if the covers have been removed.

-We decline all responsibility for damages and injuries caused by an improper use of the module. It is strongly recommended to read the operators manual before operation.

Notice

The information in this manual is subject to change without notice. We take no responsibility for any error in the document. We reserve the right to make changes in the product design without reservation and without notification to the users.

Filename SHQx2x_V301_eng.____; version 3.01 as of 22.10.01

1. General information

The SHQ is a high voltage desk top family of instruments which offer output voltages up to 6 kV for use in industry and research.

Main Characteristics:

- High voltage desk top power supplies with either front-panel or remote control via serial interface
- Output voltages with very low ripple and noise
- Compact and ruggedized enclosure with 1 or 2 independent high voltage power supplies
- Polarity manual switchable
- Simultaneous indication of current and voltage in HIGH RESOLUTION format on the 2-line LCD display
- Output short circuit and overload protection

2. Technical Data

TECHNICAL DATA	HIGH PRECISION		
Single channel HV Power Supply	SHQ 122	SHQ 124	SHQ 126
Dual channel HV Power Supply	SHQ 222	SHQ 224	SHQ 226
Output voltage V_O	0...2 kV	0...4 kV	0...6 kV
Output current I_O	0...6 mA	0...3 mA	0...1 mA
Ripple and noise	typ.: < 2 mV _{P-P}		max.: 5 mV _{P-P}
Stability: $\frac{\Delta V_O}{\Delta V_{INPUT}}$	< $5 * 10^{-5}$ (after a warm-up period from 30 min)		
$\frac{\Delta V_O}{\Delta V_O}$ (no load/ load)	< $3 * 10^{-5}$ (after a warm-up period from 30 min)		
Temperature coefficient	< $3 * 10^{-5}/^{\circ}C$		
Voltage measurement resolution:	0.1 V [Option VHR : 10 mV (up to 4 kV)] / 6-digit LCD display		
accuracy:	$\pm (0,05\% V_O + 0,02\% V_{O\ max})$		
Current measurement resolution:	2 ranges / 6-digit LCD display 1 st Range $I_{O\ MAX}$ [mA]: resolution 100 nA 2 nd Range 100 μ A: resolution 1 nA (Option 0n1 : 2 nd Range 10 μ A: resolution 100 pA)		
accuracy:	$\pm (0,1\% I_O + 0,02\% I_{O\ max})$		
Voltage settings manual:	10-turn potentiometer		
DAC:	digital via serial interface		
Rate of change of output voltage	fixed: 500 V/s (at HV-ON/OFF) variable: 2 ... 255 V/s (at remote control)		
Protection	<ul style="list-style-type: none"> -hardware voltage limit (rotary switch in 10%-steps) -hardware current limit (rotary switch in 10%-steps, Option IWP: setting with 10-turn potentiometer) -INHIBIT (external signal, TTL-level, Low = active) -programmable current trip (software) 		
Interface	RS 232-Interface (Option CAN : CAN-Interface \Rightarrow SHQ x4x)		
Line voltage AC (V_{INPUT})	230 V _{AC} ^{+10%} / _{-15%} (Option ACW ¹⁾ : 95 V _{AC} ... 265 V _{AC})		
Connectors	HV output: SHV-Connector INHIBIT: 1-pin Lemo-hub RS 232 (opt. CAN): 9-pin female D-Sub connector		
Desk case	Size (W/H/D) : (236/100/320) mm		
Operating temperature	0 ... +50 $^{\circ}C$		
Storage temperature	-20 ... +60 $^{\circ}C$		

The **built-in options** are signed on the name plate on the rear side!

¹⁾ **Option ACW:** The state-of-readiness of the unit will be achieved ca. 10 s after power up the AC line voltage from 110 V-AC \pm 10% !

3. SHQ Description

The functions are described with reference to a block diagram of the SHQ, shown in Appendix A.

High voltage supply

A patented high efficiency resonance converter circuit, which provides a low harmonic sine voltage on the HV-transformer, is used to generate the high voltage. The high voltage is rectified using a high speed HV-rectifier, and the polarity is selected via a high-voltage switch. A consecutive active HV-filter damps the residual ripple and ensures low ripple and noise values as well as the stability of the output voltage. A precision voltage divider is integrated into the HV-filter to provide the set value of the output voltage; an additional voltage divider supplies the measuring signal for the maximum voltage control. A precision measuring and AGC amplifier compares the actual output voltage with the set value given by the DAC (computer control) or the potentiometer (manual control). Signals for the control of the resonance converter and the stabilizer circuit are derived from the result of the comparison. The two-stage layout of the control circuit results in an output voltage, stabilized with very high precision to the set point.

Separate security circuits prevent exceeding the front-panel switch settings for the current I_{\max} and voltage V_{\max} limits. A monitoring circuit prevents malfunction caused by low supply voltage.

The internal error detection logic evaluates the corresponding error signals and the external INHIBIT signal. It allows the detection of short overcurrent due to single flashovers in addition.

Digital control unit

A micro controller handles the internal control, evaluation and calibration functions of both channels. The actual voltages and currents are read cyclically by an ADC using a multiplexer and processed for display on the 4 digit LCD display. The current and voltage hardware limits are retrieved cyclically several times per second. The reference voltage source provides a precise voltage reference for the ADC and generation of the control signals in the manual operation mode of the unit.

The set values for the corresponding channels are generated by a 18-bit DAC in computer controlled mode.

Filter

A special property of the unit is a tuned filtering concept, which prevents radiation of electromagnetic interference into the unit, as well as the emittance of interference by the module. A filtering network is located next to the connectors for the supply voltage and the converter circuits of the individual devices are also protected by filters. The high-voltage filters are housed in individual metal enclosures to shield even minimum interference radiation.

Floating HV-outputs

The HV outputs are related to the same ground HV-0V (HV-GND), outer connector (screen of HV cable) of SHV connectors. The channels can be switched independently in polarity and are also independently controlled in output voltage related to HV-0V (HV-GND).

The SHV connectors are mounted isolated to chassis (PE) in order to have a floating HV-0V.

In case of the floating voltage will become more than 47V a suppressor diode connects HV-0V to PE (chassis) and so far avoids that the voltage between HV-0V and PE/chassis will become dangerous.

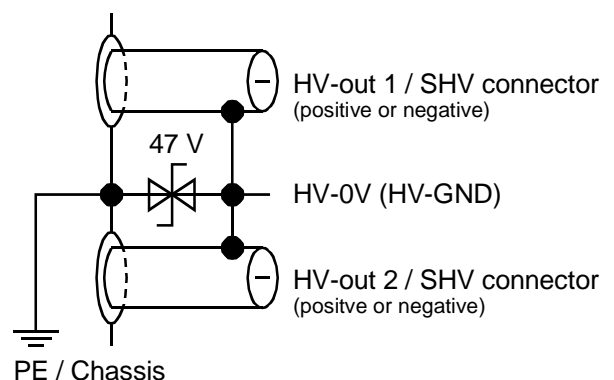

4. Front panel

Option IWP: Hardware current limit with 10-turn potentiometer

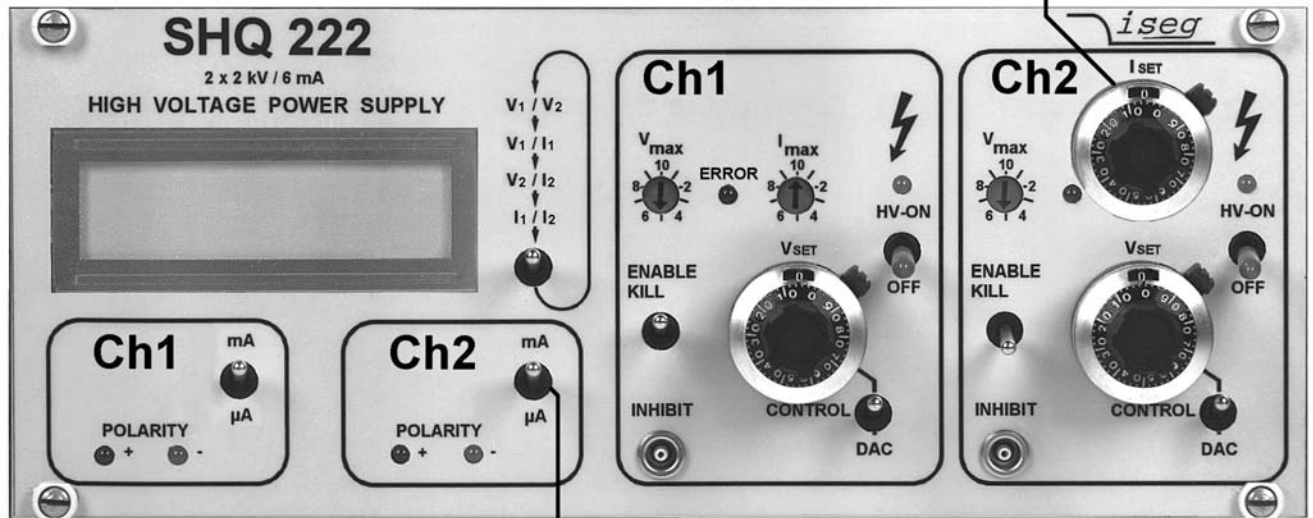

Setting current measurement

Channel 1 shows the panel for the SHQ module without the option IWP. The option IWP "Hardware current limit setting with 10-turn potentiometer" is shown on the panel Channel 2, on the right side.

5. Operation

The state-of-readiness of the unit is detected by monitoring the AC line voltage, the 9 pin female D-Sub connector for the serial interface and the HV-output on the rear.

Option ACW: The state-of-readiness of the unit will be achieved ca. 10 s after power up the AC line voltage from 110 V-AC \pm 10% !

The Output Polarity is selectable with help of a rotary switch on the rear of the unit. The selected polarity is displayed by a LED on the front panel and a sign on the LCD display.

WARNING! Do not change the polarity under power!

An undefined Output Polarity switch setting (not at one of the end positions) will result in no output voltage.

High voltage output is switched on with HV-ON switch at the front panel. This condition is signalled by the yellow LED over the switch.

WARNING! If the CONTROL switch is in upper position (manual control), high voltage is generated at HV-output on the flip side with a ramp speed from 500 V/s (hardware ramp) to the set voltage chosen via 10-turn potentiometer (V_{SET}). This is also the case if RS232 control is switched over to manual control while operating.

If the CONTROL switch is in lower position (DAC), high voltage will be activated only after receiving corresponding RS232 commands.

WARNING! During last operation of the unit the user activated the function "Autostart", the high voltage will be turned on immediately with the saved parameters!

The type of display can be selected by briefly toggling the switch next to the 2 line LCD display. Voltages and / or currents are indicated with the resolution of voltage- and current measurement of the corresponding SHQ series.

Maximum output voltage can be hardware selected in 10%-steps with the rotary switches V_{max} (switch dialled to 10 corresponds to 100%). The output voltage will be limited to V_{max} .

If working with manual control, output voltage can be set via 10-turn potentiometer in a range from 0 to the set maximal voltage.

If the CONTROL switch is switched over to remote control, the DAC takes over the last set output voltage of manual control. Output voltage can be generated with a programmable ramp speed (software ramp) from 2 to 255 V/s in a range from 0 to the maximal set voltage via the interface.

The maximum output current per channel can be set with a programmable current trip via the interface with the resolution of maximum current measurement range. If the output current exceeds the programmable limit, the output voltage will be shut off permanently by the software. Restoring the voltage is possible only after "Read status word" and then "Start voltage change" via the serial interface. If "Auto start" is active, "Start voltage change" is not necessary.

Maximum output current can be hardware selected independently of programmable current trip

- in 10%-steps with the rotary switches I_{max} (switch dialled to 10 corresponds to 100%) or
- optionally with the 10-turn potentiometer I_{SET} .

If the output voltage or current exceeds the limits, is this signalled by the red error LED on the front panel.

The resolution of current measurement can be preset with the switch „Setting current measurement“. There by the setting range of the hardware current limit and maximum output current are defined. 100 % I_{max} or I_{SET} always corresponds to the maximum current measurement data of the chosen sector. The automatic measurement range selection for current measurement and display only functions in the direction of higher resolution and does not influence the setting range of the hardware current limit.

Function of the KILL switch:

Switch to the upper position: (ENABLE KILL)	The output voltage will be shut off permanently without ramp on exceeding I_{max} / I_{SET} or in the presence of an INHIBIT signal (Low=active) at the INHIBIT input. Restoring the output voltage is possible after operating the switches HV-ON or KILL or "Read status word" and then "Start voltage change" by DAC control. If "Auto start" is active, "Start voltage change" is not necessary.
--	--

Note:	When capacitance is present at the HV-output or when the rate of change of output voltage is high (hardware ramp) at high load, then the KILL function will be released by the current charging the condenser. In this case use a small rate of output change (software ramp) or select ENABLE KILL not until output voltage is set voltage.
-------	--

Switch to the lower position: (DISABLE KILL)	The output current will be limited to I_{max} / I_{SET} ; INHIBIT shuts the output voltage off without ramp, the previous voltage setting will be restored with hard- or software ramp on INHIBIT no longer being present.
---	--

6. RS232 interface

The most important parameters of the high voltage supply can be set and read under computer control via the RS232 interface.

RS232 control mode

1 st Write function:	set voltage; ramp speed; maximal output current (current trip); auto start
2 nd Switch function:	output voltage = set voltage, output voltage = 0
3 rd Read function:	set voltage; actual output voltage; ramp speed; actual output current; current trip; auto start ; hardware limits current and voltage; status

Front panel switches are having priority over software control.

Manual control mode

While the unit is operated in manual control mode, RS232 read cycles are interpreted only. Commands are accepted, but do not result in a change of the output voltage.

Specification RS232 interface

The data exchange is character based, synchronisation between the computer and the supply (input) is performed using echo. The data transfer to the computer (output) is asynchronous, breaks between two characters, programmable of the break time, allow the computer to receive and evaluate the incoming data. Break time is setting 3 ms at works.

The hardware setting of the RS232 interface is 9600 bit/s, 8 bit/character, no parity, 1 stop bit.

Signal transmission is performed potential free via the RxD and TxD, relative to GND.

The HV-supply is equipped with a 9 pin female D-Sub connector, the connection can be set up using a 1:1 extension cord (no null modem cable) when a PC is used. The pin assignment is given in table 1. Control signals to be bridged on the PC side when a three lead cable is used, are given in table 1 also.

Table 1:

Signal RS 232	HV-supply		PC DSUB9	PC DSUB25	Connection 3-lead cable
	DSUB9	Int.			
RxD	2		2	3	
TxD	3		3	2	
GND	5		5	7	
	4	⌋	4	20	⌋
	6		6	6	
	8		8	5	

Syntax

The commands are transmitted in ASCII. The end of command is formed by the sequence <CR> <LF> (0x0D 0x0A , 13 10 respectively). Leading zeroes can be omitted on input, output is in fixed format.

Command set

Command	Computer	HV-supply
Read module identifier	# *	# * nnnnnn ; n.nn ; U ; I * (unit number ; software rel. ; V _{out max} ; I _{out max})
Read break time	W *	W * nnn * (break time 0 ... 255 ms)
Write break time	W=nnn *	W=nnn ** (break time = 0 - 255 ms)
Read actual voltage channel 1	U1 *	U1 * { polarite / mantisse / exp. with sign } * (in V)
Read actual current channel 1	I1 *	I1 * { mantisse / exp. with sign } * (in A)
Read voltage limit channel 1	M1 *	M1 * nnn * (in % of V _{out max})
Read current limit channel 1	N1 *	N1 * nnn * (in % of I _{out max})
Read set voltage channel 1	D1 *	D1 * { mantisse / exp. with sign } * (in V)
Write set voltage channel 1	D1=nnnn.nn *	D1=nnnn.nn ** (voltage corresponding resolution in V; <M1)
Read ramp speed channel 1	V1 *	V1 * nnn * (2 ... 255 V/s)
Write ramp speed channel 1	V1=nnn *	V1=nnn ** (ramp speed = 2 - 255 V/s)
Start voltage change channel 1	G1 *	G1 * S1=xxx * (S1 , ⇒ Status information)
Write current trip	L1=nnnnn *	L1=nnnnn ** (trip corresponding resolution range mA > 0)
cannel 1	Range "mA" LB1=nnnnn *	LB1=nnnnn ** (trip corresponding resolution range mA > 0)
	Range "µA" LS1=nnnnn *	LS1=nnnnn ** (trip corresponding resolution range µA > 0)
Read current trip	L1 *	L1=nnnnn ** (see above, for nnnnn=0 ⇒ no current trip)
cannel 1	Range "mA" LB1 *	LB1=nnnnn ** (see above, for nnnnn=0 ⇒ no current trip)
	Range "µA" LS1 *	LS1=nnnnn ** (see above, for nnnnn=0 ⇒ no current trip)
Read current trip channel 1	L1 *	L1 * { mantisse / exp. with sign } * (s.a., current trip in A)
Read status word channel 1	S1 *	S1 * xxx * (S1 , ⇒ Status information)
Read module status channel 1	T1 *	T1 * nnn * (code 0...255, ⇒ Module status)
Write auto start channel 1	A1=nn *	A1=nn ** (conditions ⇒ Auto start)
Read auto start channel 1	A1 *	A1 * nnn * (8 ⇒ auto start is active; 0 ⇒ inactive)

* = <CR><LF>

The second channel of the supply is addressed by replacing 1 with 2 !

Status information:

xxx:	ON<SP>	Output voltage according to set voltage
	OFF	Channel front panel switch off
	MAN	Channel is on, set to manual mode
	ERR	V_{max} or I_{max} is / was exceeded
	INH	Inhibit signal was / is active
	QUA	Quality of output voltage not given at present
	L2H	Output voltage increasing
	H2L	Output voltage falling
	LAS	Look at Status (only after G-command)
	TRP	Current trip was active

If output voltage shut off permanently (by ERR or INH at ENABLE KILL or TRP) you must do "Read status word" before the output voltage restoring is possible.

Error codes:

????	Syntax error
?WCN	Wrong channel number
?TOT	Timeout error (with following reinitialization)
?<SP>UMAX=nnnn	Set voltage exceeds voltage limit

Module status:

Status	Description	Bit	Valency
QUA	Quality of output voltage not given at present	7=1	128
ERR	V_{max} or I_{max} is / was exceeded	6=1	64
INH	INHIBIT signal	was / is active	5=1
		inactive	0
KILL_ENA	KILL-ENABLE is	on	4=1
		off	0
OFF	Front panel HV-ON switch in	OFF position	3=1
		ON position	0
POL	Polarity set to	positive	2=1
		negative	0
MAN	Control	manual	1=1
		via RS 232 interface	0
		0=0	0

Auto start:

Description		Bit	Valency
If module status OFF + ERR + INH + MAN = 0, output voltage of the channel ramping at set voltage. G-command is not necessary after D-command, POWER-ON and OFF ⇒ ON. If output voltage shut off permanently (by ERR or INH at ENABLE KILL or TRP), the previous voltage setting will be restored with software ramp after "Read status word".		3=1	8
Values loading in corresponding registers at POWER-ON!	Current trip saving in EEPROM	2=1	4
	Set voltage saving in EEPROM	1=1	2
	Ramp speed saving in EEPROM	0=1	1

(EEPROM guarantee 1 million saving cycles)

Software

Contact us for an overview on our user friendly control and data acquisition software!

7. Program example

```

/*****
/*
/*      shq.cpp
/*
/*      example program for iseg shq hv power supply, written by Jens Römer, 27.2.97 */
/*
/*      this code was compiled under BC, please contact iseg for the source file
/*
/*
/*****

#include <dos.h>
#include <stdio.h>
#include <conio.h>
#include <stdlib.h>
#include "int14.h"                // COM2 handling

const      etx= 0x03;
const      f = 0x0a;
const      cr = 0x0d;
unsigned   char readU[]={ 'U', '1', cr, lf, etx};           //read voltage
unsigned   char sendU[]={ 'D', '1', '=', '1', '0', cr, lf, etx}; //set voltage to 10V
unsigned   char *ptr;
unsigned   char rby;
int        i, cnt;
boolean    ok;

void main(void)
{
    clrscr();
    COM2_init();
    COM2_set(9600);                // COM2:      9600 baud, 8 databits, no parity, 1 stopbit
    ok=True_;
    ptr=readU;
    for (;;)
    {
        if (*ptr==etx) break;
        COM2_send(*ptr);           //send one byte
        rby=COM2_read();           //read one byte
        if (rby!=*(ptr++)) ok=False_; //compare sent with read data
        else switch (rby)
        {
            case lf : printf("%c",lf); break;
            case cr : printf("%c",cr); break;
            default : printf("%c",rby); break;
        }
        if (ok==False_)
        {
            printf("No coincident read data found!");
            exit(1);
        }
    }
    cnt=8;
    do
    {
        rby=COM2_read();           //read voltage data
        switch (rby)
        {
            case lf : printf("%c",lf); break;
            case cr : printf("%c",cr); break;
            default : printf("%c",rby); break;
        }
        cnt--;
    } while (cnt>=1);
}

```

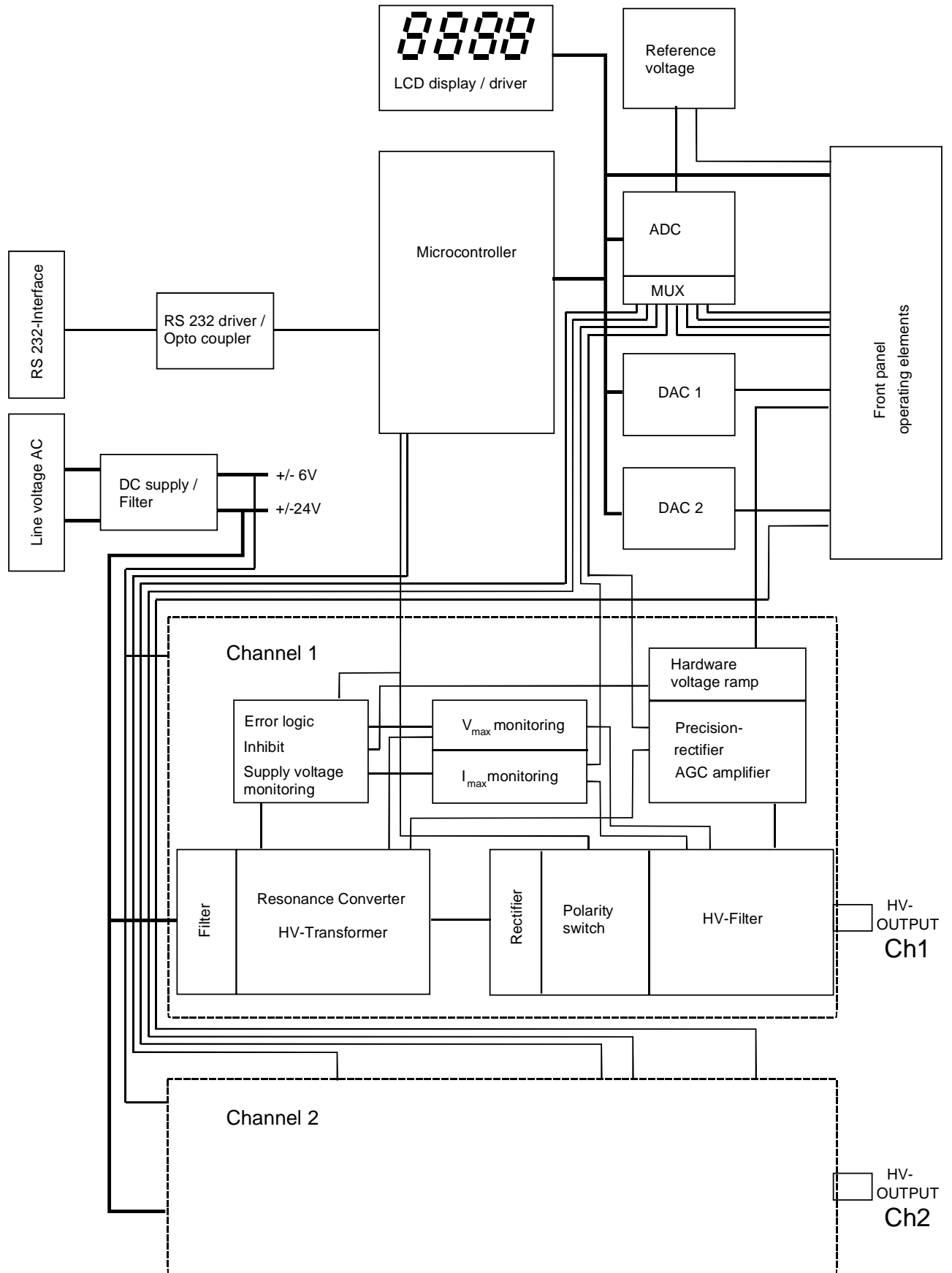

Appendix A: Block diagram SHQ