

MECHANICAL AND VACUUM DESIGN OF THE WIGGLER SECTION OF THE ILC DAMPING RINGS*

O.B. Malyshev[†], ASTeC, STFC DL and the Cockcroft Institute, Warrington, UK.

J.M. Lucas, N. Collomb, S. Postlethwaite, ETC, STFC DL and Cockcroft Institute, Warrington, UK.

M. Korostelev, A. Wolski, Dept. of Phys., University of Liverpool, and CI, Warrington, UK.

K. Zolotarev, BINP, Novosibirsk, Russia.

Abstract

The design of the vacuum vessel for the wiggler sections of the ILC damping rings should meet a number of challenging specifications. Synchrotron radiation (SR) power of about 40 kW is generated in each wiggler. The expanding fan of SR reaches the beam vacuum chamber walls in the following wiggler and may cause the following problems: large power dissipation on vacuum chamber walls inside the cryogenic vessel; radiation damage of superconducting coils; high photo-electron production rate causing electron cloud to build up to an unacceptable level. Therefore, the power should be absorbed in places where these effects are tolerable or manageable. Some possible solutions for tackling all SR related problems as well as the vacuum design are discussed.

INTRODUCTION

The mechanical and vacuum design of the damping rings (DRs) for the International Liner Collider (ILC) is based on the DCO4 lattice design [1]. A key part of the damping ring is a wiggler section of length 374 m, consisting of 44 regular FODO cells with two wiggler modules per cell. The vacuum design of this section must satisfy the beam dynamics requirements, including: beam pipe aperture [1], vacuum chamber impedance [2], mitigation of electron cloud effects [3-5], suppression of ion induced pressure instability [6] and power absorption [7]. At the same time, the cost should not be excessive either directly in terms of manufacture, or indirectly in terms of increased magnet aperture or maintenance requirements.

A similar trade-off needs to be made for the support structures, which (for example) need to be effective in isolating machine components from vibrations, yet be simple enough in manufacture to keep cost to a minimum. The 'Fit, Form and Function' considerations are mainly governed by envelope constraints. Although the large scale of the DRs may appear to provide sufficient space for systems and associated mechanical design components, close examination of certain sections highlights the fact that space is in fact at a premium.

* Work supported by the Science and Technology Facilities Council, UK.

[†] oleg.malyshev@stfc.ac.uk

DESIGN OVERVIEW

The 3D layout of a wiggler module in the positron DR (located directly above the electron DR beam line) is shown in Fig. 1. The wiggler cryostat is a graphical representation (place holder) only, based on the envelope provided by the Cornell design [3].

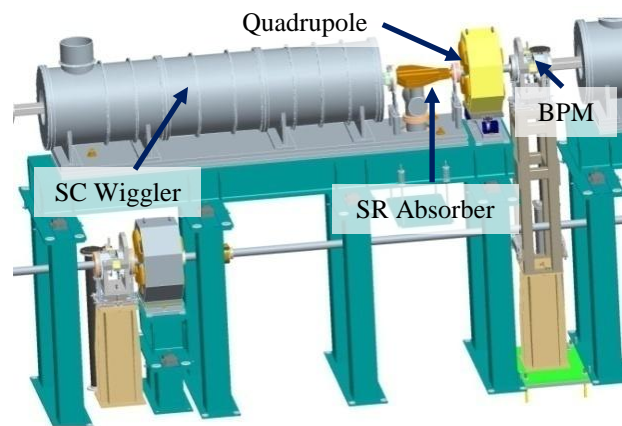

Figure 1: Wiggler module in the positron damping ring.

Fig. 2 shows the components between wiggler modules in more detail. The 5-axis mover system allows orbit correction to be achieved by moving the quadrupole instead of by use of a separate dipole steering magnet: this enables sufficient space to be provided for the photon absorber.

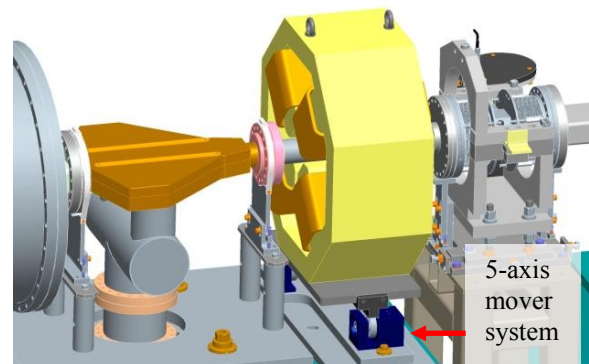

Figure 2: Wiggler module components.

Each wiggler module generates 40 kW SR power; this raises a number of issues:

- The power needs to be absorbed safely.

- Sufficient pumping must be provided to achieve a good vacuum in the presence of high rates of photon-stimulated desorption.
- SR impacting the chamber walls can lead to high rates of photoelectron emission, resulting in build-up of electron cloud: this can be particularly dangerous in the magnetic fields of the wigglers and quadrupoles.
- The BPM assembly should be protected from SR.

Wiggler Vacuum Chamber

The design of the wiggler vacuum chamber follows that developed at Cornell [3]. Fig. 3 depicts internal details of the chamber. The design can be manufactured out of extruded aluminium, thus eliminating a ‘split top-bottom’ design that would have an inherent leak risk and would require additional operations during fabrication. Assembly is more complicated using an extruded vessel, but this disadvantage is outweighed by the advantages of cost, reliability and simpler ‘operation’.

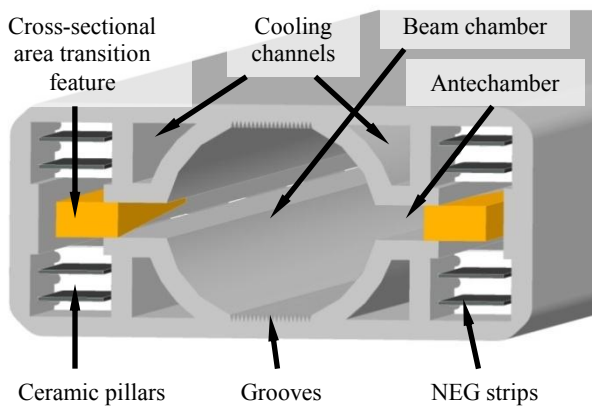

Figure 3: Wiggler vacuum chamber cross section.

Since electron cloud is a potential threat in the positron DR (especially in magnetic elements such as wigglers and quadrupoles), the wiggler vacuum chamber should include mitigation techniques. The results from various experiments and models of electron cloud build-up help us to identify a number of possible measures [3-4], some of which are incorporated in this design. There are three sources for electrons within the positron DR chamber: photoelectrons, secondary electrons, and beam induced residual gas ionisation. The number of photoelectrons in the beam chamber can be efficiently reduced with the use of antechambers that allow a significant fraction of photons to pass along the wiggler vacuum chamber without striking the walls, and to be absorbed outside the wiggler. The antechamber can also be used for distributed pumping with NEG strips as shown in Fig. 3. Grooves along the top and the bottom of beam chamber (also shown in Fig. 3) can suppress secondary electron emission; in addition, the beam chamber inner surface should be coated with TiN. An alternative solution is an integrated electrode (not shown, see reference [8]) that could be used instead of grooves.

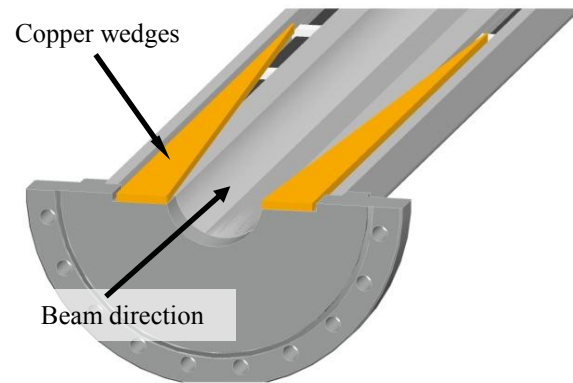

Figure 4: Wiggler vacuum entrance with copper wedges in the antechamber to provide smooth aperture transition.

The copper wedges shown in Fig. 4 are required for a smooth transition between the round vacuum chamber upstream from a wiggler and the vacuum chamber with an antechamber inside the wiggler. Based on impedance considerations [2], the taper angle is approximately 7° .

SR Power Absorber

While the chamber in the wiggler module is designed to minimise the SR falling onto it, the SR power absorber poses a different challenge, since the system is designed so that most of the 40 kW radiation power from each wiggler module will fall onto an absorber. The spacing between wiggler modules (driven by beam dynamics considerations) limits the length of the power absorber to about 500 mm. A solution for such high power absorption was originally developed at BINP, for SR absorbers designed for Siberia-2 LS (Russia). The SR hits an absorber with a saw-tooth surface geometry, ramped at an angle of 40 mrad (see Fig. 5). The reflected photons and photoelectrons are intercepted with a horizontal plate closing the absorber from the top. A similar geometry is used in crotch absorbers in the Diamond Light Source (UK).

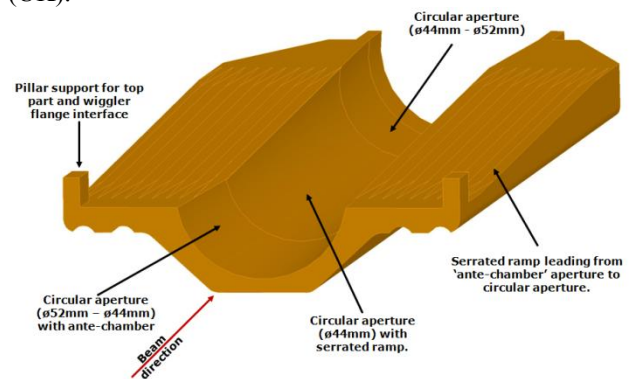

Figure 5: SR power absorber.

Due to the length of the wiggler section, SR will hit the inner walls of the beam chamber. To shadow the downstream quadrupole and BPM chambers the absorber beam pipe should taper to an inner diameter of 44 mm. A smooth transition from 52 mm to 44 mm, and then back

to 52 mm, is shown in Fig. 7. Studies show that the impedance of this geometry is acceptable [2].

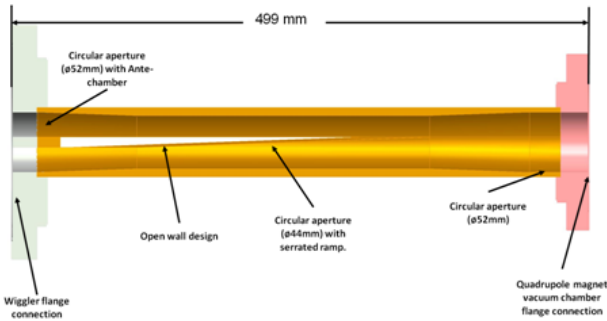

Figure 6: Longitudinal cross section of SR power absorber beam chamber.

The gap between the ramped saw-tooth surface and the plate above it (see Figs. 6 and 7) provides sufficient vacuum conductance to pumped antechambers. A pump is connected to the antechambers through ducts (100 mm diameter) leading to a vacuum canister. Pumping occurs through the bottom flange (see Fig. 2).

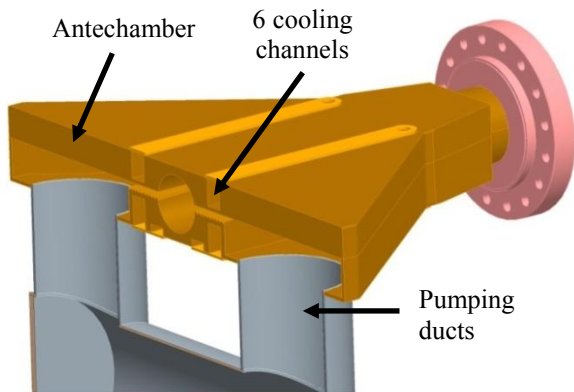

Figure 7: Transverse cross section of SR power absorber vacuum chamber.

The thermal power is dissipated by cooling channels machined sufficiently close to the radiated surfaces (but not too close to cause the material to ‘melt’) as shown in Fig. 7. The top is designed as a solid block thus making use of all three heat transfer methods: conduction, convection and radiation. OF copper is the material of choice, but needs to be confirmed. Further investigation is required to validate that the component will survive under steady state conditions. It is intended to carry out a thermal analysis (using a Finite Element Analysis method) in the near future, based on an assumption of a flat energy distribution.

Quadrupole and BPM Vacuum Chambers

The vacuum chamber passing through the quadrupole magnet is a simple tube, of length 454 mm and internal diameter 52 mm, with flanges at either end. This is a simple and cost effective design.

The Beam Position Monitor (Fig. 8) has essentially the same design as that used in the arc cells, the main difference being that the flanges are circular, thus reducing complexity and cost. The buttons are recessed in a slightly larger aperture from the chamber on either side, to improve shadowing from SR.

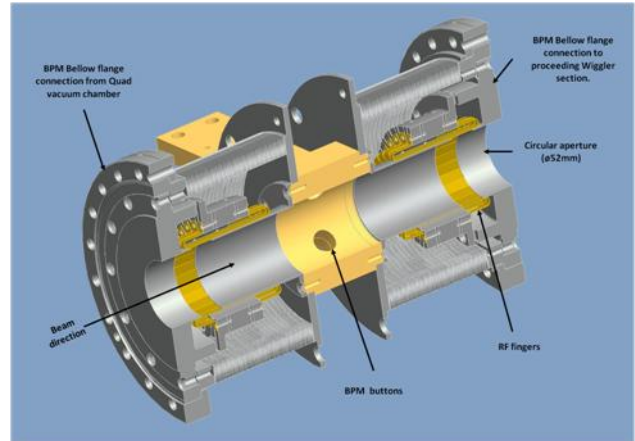

Figure 8: BPM assembly.

CONCLUSIONS

A first design for the vacuum and mechanical components of the wiggler section has been completed. It satisfies the requirements from impedance, electron cloud, power absorption and vacuum models, at a reasonable cost. A detailed design model is available for further improvements and refinements, and for other DR studies connected with the vacuum and mechanical design, including impedance modelling [2], power deposition modelling [7], electron cloud studies, etc. Although the design has been developed for the 6.4 km ring, many of the design details could also be used for a 3.2 km damping ring.

REFERENCES

- [1] M. Korostelev *et al*, “DCO4 lattice design for 6.4 km ILC damping ring”, WEPE096, these proceedings (IPAC’10).
- [2] M. Korostelev and A. Wolski, “Impedance and single-bunch instabilities in the ILC damping ring”, WEPE095, these proceedings.
- [3] M. Palmer, “CesrTA project status, results and future plans”, presentation at AEC09, CERN, 12-13 Oct 2009.
- [4] M. Pivi *et al*, “Groove mitigation and plans”, presentation at AEC09, CERN, 12-13 Oct 2009.
- [5] O.B. Malyshev, “ILC DR vacuum design and e-cloud”, Proceedings of EPAC08, Genoa, Italy, p. 673.
- [6] O.B. Malyshev, “Ion induced pressure instability in the ILC positron damping ring”, WEPE093, these proceedings.
- [7] K. Zolotarev, O.B. Malyshev, M. Korostelev, *et al*, “SR power distribution along wiggler section of ILC damping rings”, WEPE094, these proceedings.
- [8] M. Zobov *et al*, “Impact of ion clearing electrodes on beam dynamics in DAΦNE”, ECL2 proceedings, CERN, Geneva, Switzerland, 1-2 March, 2007.