

# EMC Components

## ZCYS Series

### Common-Mode Choke Coils for Signal Line SMD

#### FEATURES

- The ZCYS series common-mode choke coils provide highly effective noise rejection characteristics without distorting the transmission signal. Especially, most available for USB interface circuit.
- Well suited as a countermeasure against high-frequency radiation noise in small signal interface lines, this product is a space-efficient solution for multiple-line cable applications.
- A high level of miniaturization has been achieved with a maximum height of 2.5mm.

#### APPLICATIONS

Personal computers, telephones, LANs, ISDNs, digital PBXs, word processors, electronic games, palm-sized computing devices, CTVs, CD-ROM drives, 8mm video cameras.

#### SHAPES AND DIMENSIONS/RECOMMENDED PC BOARD PATTERNS

##### ZCYS51R5-2PAT

##### ZCYS51R5-M3PAT

##### ZCYS51R5-M3PA7T

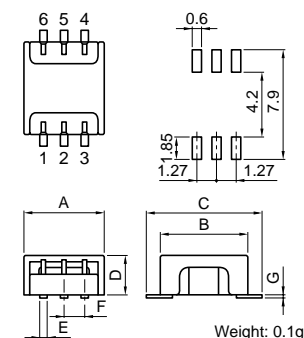

##### ZCYS51R5-M4PAT

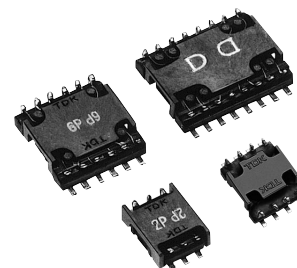
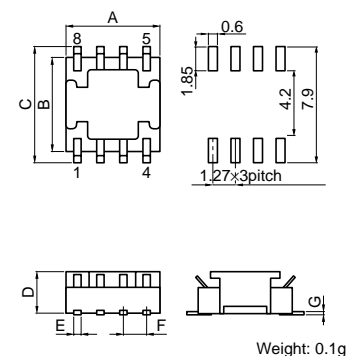

##### ZCYS51R5-M6PT

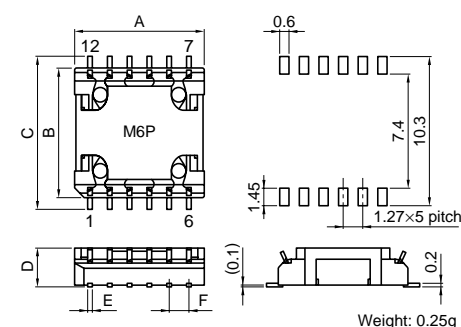

##### ZCYS51R5-M8PT

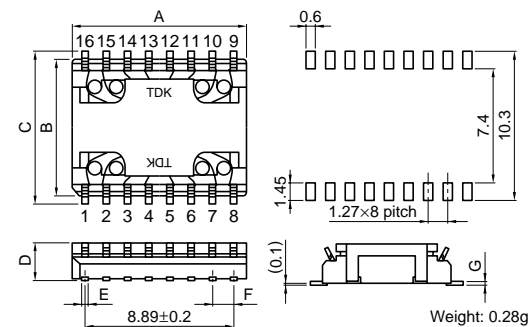

Part No.	A max.	B	C±0.5	D max.	E	F±0.15	G
ZCYS51R5-2PAT*	5.2	6	7	2.5	0.39	1.27	0.2
ZCYS51R5-M3PA(7)T							
ZCYS51R5-M4PAT	5.7	5.7	7	2.5	0.4	1.27	0.2
ZCYS51R5-M6PT	8.5	8.5	9.4	2.5	0.39	1.27	0.2
ZCYS51R5-M8PT	11	8.5	9.4	2.5	0.39	1.27	0.2

\* T means the taping product.

#### CIRCUIT DIAGRAMS

##### ZCYS51R5-2PAT

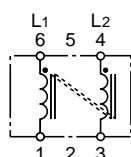

##### ZCYS51R5-M3PA(7)T

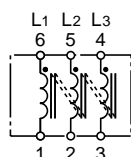

##### ZCYS51R5-M4PAT

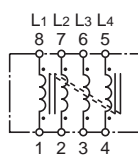

##### ZCYS51R5-M6PT

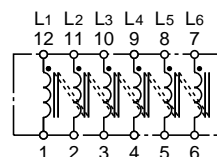

##### ZCYS51R5-M8PT

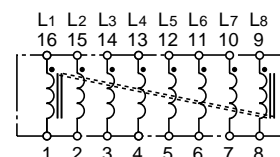

△ Specifications which provide more details for the proper and safe use of the described product are available upon request.  
All specifications are subject to change without notice.

# EMC Components

## ZCYS Series

### Common-Mode Choke Coils for Signal Line SMD

#### ELECTRICAL CHARACTERISTICS

Part No.	ZCYS51R5-2PAT	ZCYS51R5-M3PAT/ -M3PA7T	ZCYS51R5-M4PAT	ZCYS51R5-M6PT	ZCYS51R5-M8PT
Rated voltage E <sub>dc</sub> (V)	50	50	50	50	50
Rated current (A)	0.5	0.5	0.5	0.5	0.5
Test voltage E <sub>dc</sub> (V) [Between terminals for 5s]	125	125	125	125	125
Insulation resistance (MΩ) [Between terminals at DC.50V for 1min]	100min.	100min.	100min.	100min.	100min.
DC resistance (Ω) [each line]	0.3max.	0.3max./0.15max.	0.2max.	0.25max.	0.3max.
Operating temperature range(°C)	-25 to +85	-25 to +85	-25 to +85	-25 to +85	-25 to +85
Impedance (Ω) [+5 to +35°C]	400min. [50 to 300MHz]	400min.[50 to 300MHz]/ 100min.[100 to 500MHz]	200min. [100 to 500MHz]	200min. [50 to 300MHz]	100min. [100 to 300MHz]

#### TYPICAL ELECTRICAL CHARACTERISTICS

##### IMPEDANCE vs. FREQUENCY CHARACTERISTICS

(for 1 element)

##### ZCYS51R5-2PAT

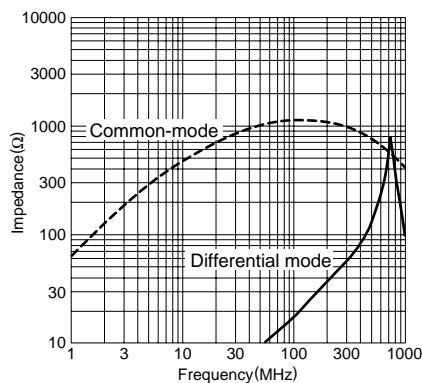

##### ZCYS51R5-M3PAT

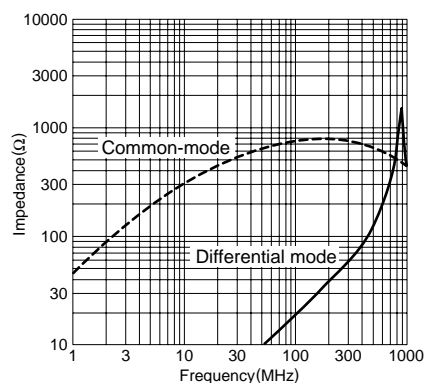

##### ZCYS51R5-M4PAT

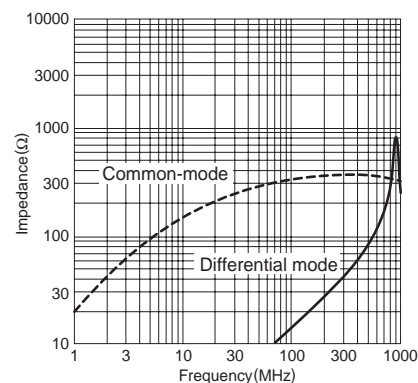

##### ZCYS51R5-M6PT

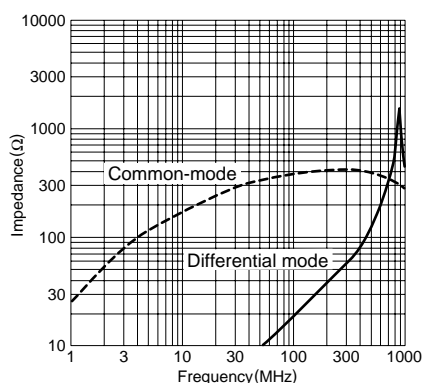

##### ZCYS51R5-M8PT

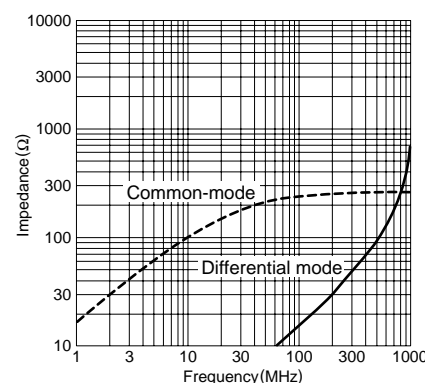

##### ZCYS51R5-M3PA7T

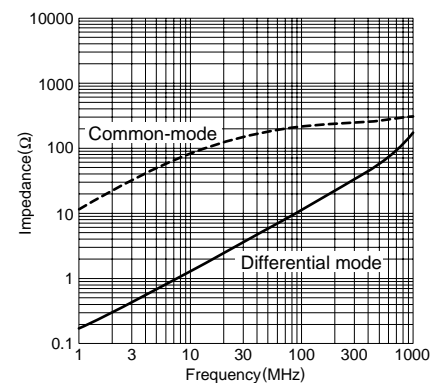

#### PACKAGING STYLE AND QUANTITIES

Packaging style	Part No.	Quantity
Taping	ZCYS51R5-2PAT	3000 pieces/reel
	ZCYS51R5-M3PA(7)T	3000 pieces/reel
	ZCYS51R5-M4PAT	3000 pieces/reel
	ZCYS51R5-M6PT	2000 pieces/reel
	ZCYS51R5-M8PT	2000 pieces/reel