

Future Physics with pp and ep

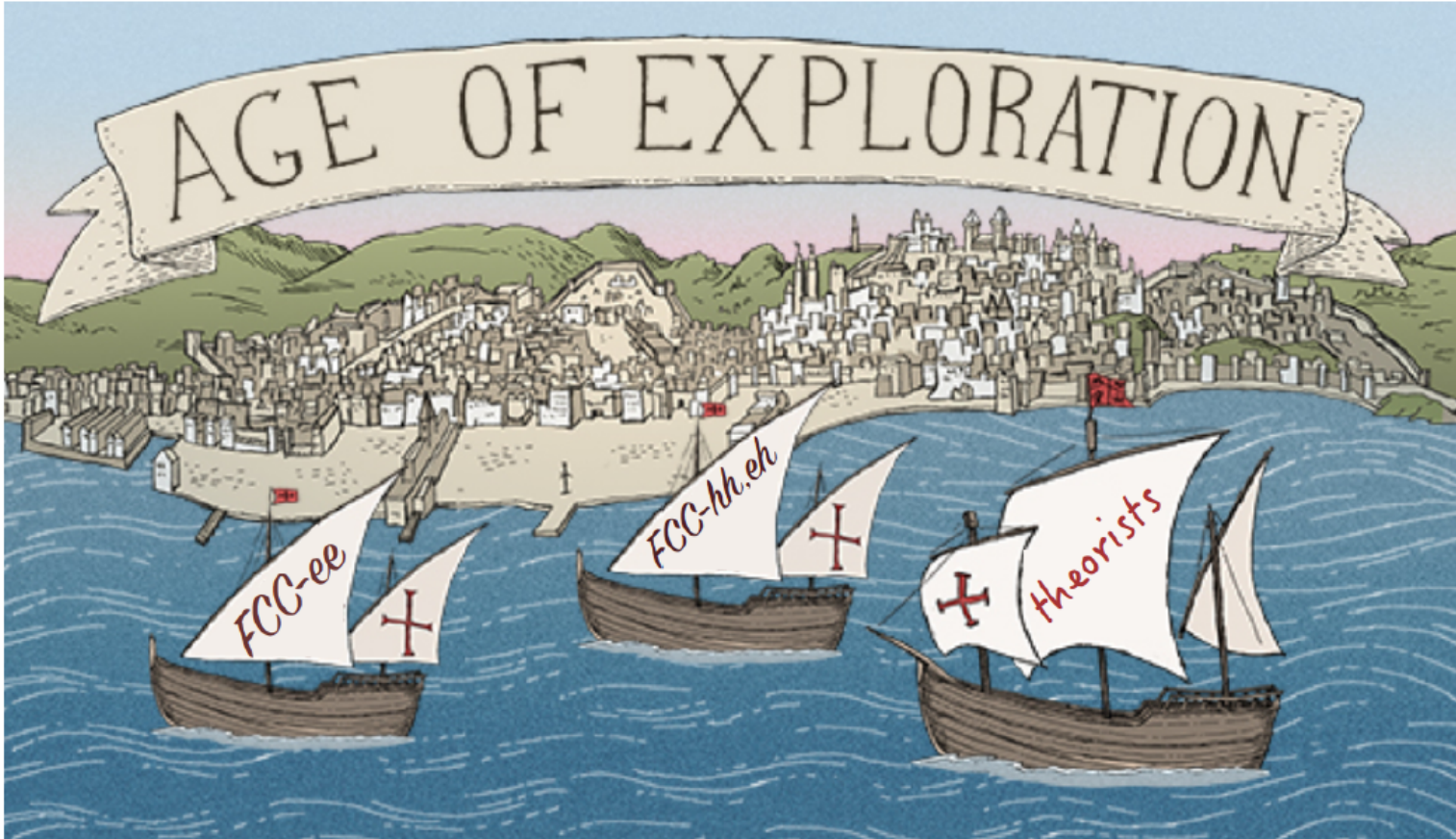

Jo Rudermann

Why going beyond the LHC?

Three remarks

FCC-pp:

Five examples for its physics

ep with pp at the LHC

FCC-eh

Remarks

Max Klein and Paul Newman,
PPAP Birmingham, 12.9.2019

Higgs at HL-LHC

$\sqrt{s} = 14 \text{ TeV}, 3000 \text{ fb}^{-1}$ per experiment

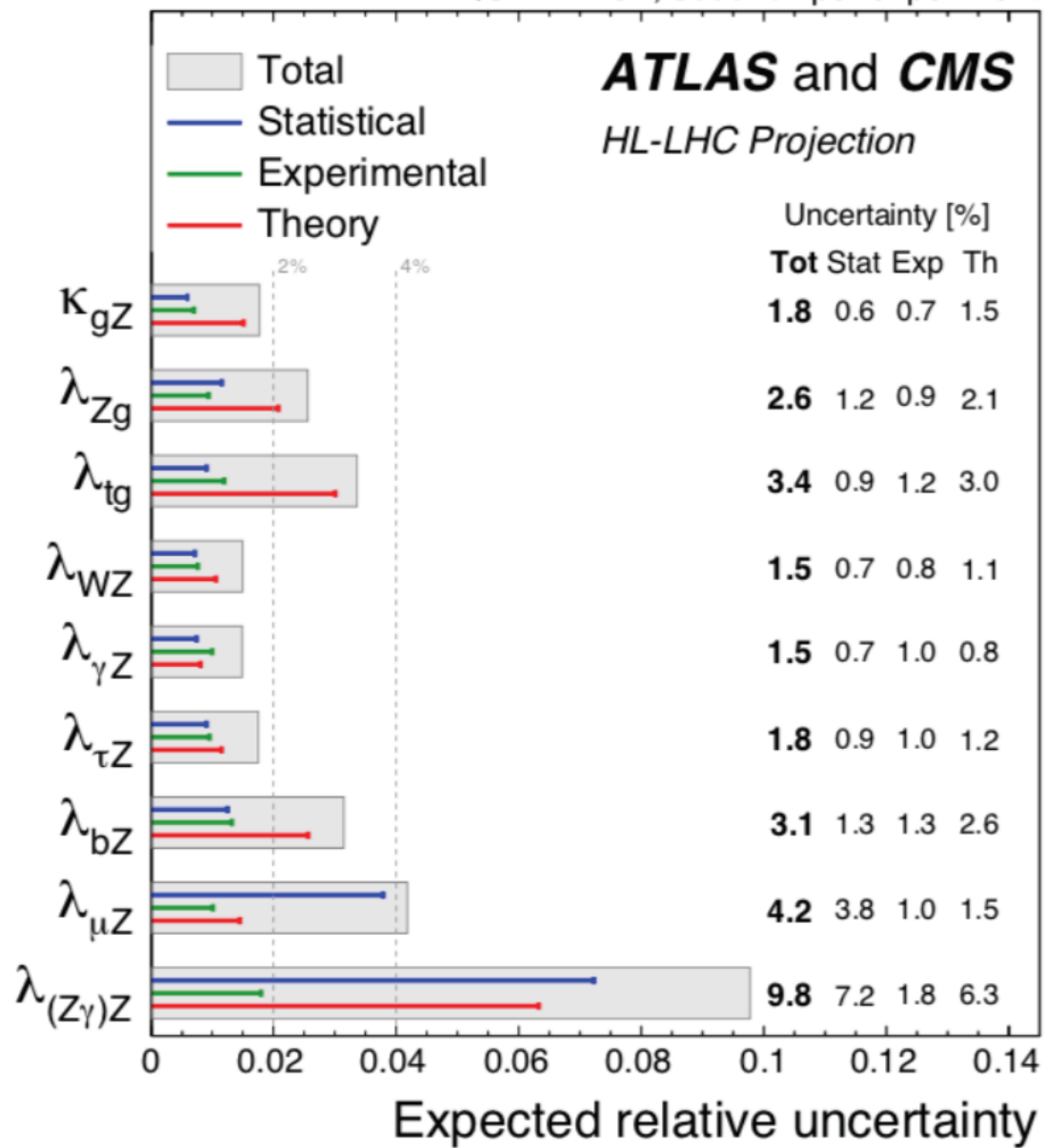

Observations and Questions:

LHC accesses rare channels, unlike e^+e^- or ep
[50 pb cross section vs 0.2 pb at these machines, 1pb FCCeh]

Most couplings in the SM will be measured to a few percent precision (no charm), much better than initially expected

The measurements are expected to be limited by QCD.

Double Higgs production may be seen at 5 sigma, if we use the time LHC offers.

It is, yet, for FCC-pp to study the H potential + self coupling

Very high precision needs higher energy and lepton Colliders (ee and ep).

Are there further (charged) Higgs particles, is the Higgs composite?

What is beyond the LHC reach (or still within?)

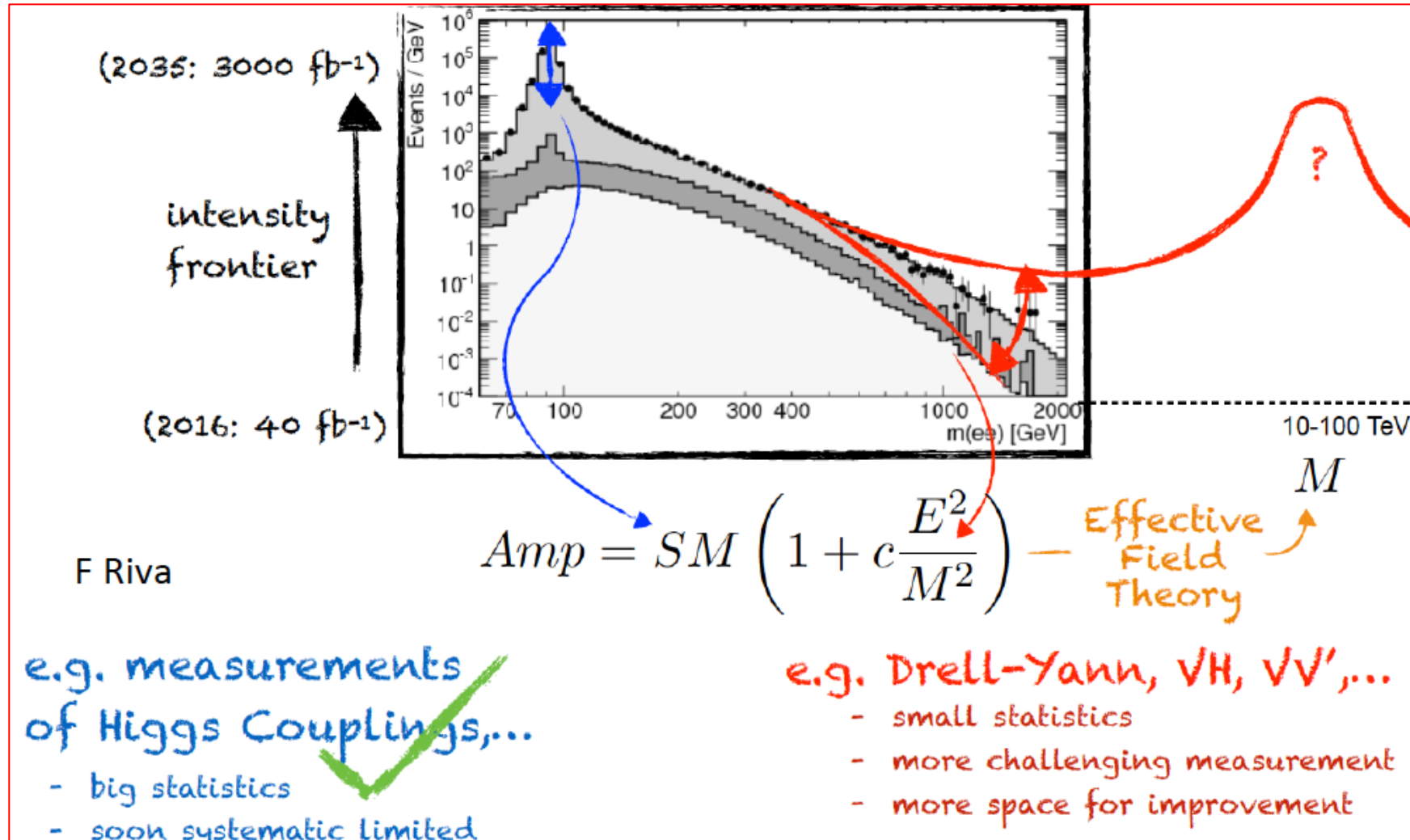

We need higher energy, higher precision and to understand the proton and its dynamics deeper: pp+ep

The SM looks complete, but PP is far from having answered its fundamental questions

- Do we have too many particles? 12 leptons, 36 quarks, 12 mediators, 1 Higgs = 61
- Is there a further layer of structure (preons?)
- How can we unify the 3 + 1 interactions (SU(5) failed in 1980 but established neutrino physics)
- Why are leptons and quarks different?
- Can one restore the boson-fermion symmetry (SUSY since 1972)
- Why do we have 3 families?
- Neutrino puzzles: Majorana, sterile neutrinos – Oscillations (98), Pontecorvo (57)
- Is the proton stable?
- How to we stabilise the Higgs Mass
- ...

New: We lost the SM guidance

PP is not astrophysics, it needs pp+ep and as well ee and neutrino, energy frontier and low energy experiments. It may be justified independently of the dark astro questions. It is as before a technology driver and challenge. There was no SM when Stanford endorsed the 2m electron linac and when CERN went for ISR and SPS.

Future Higgs Physics with FCC-pp

- The FCC-hh machine will produce $> 10^{10}$ Higgs bosons
- Such **large statistics** open up a whole new range of possibilities, allowing for precision in new kinematic regimes, and rare decay channels \rightarrow complementary to FCC-ee
- Measuring **ratios of couplings** (or equivalently BRs), allows to cancel systematics (1% precision on “rare” couplings within reach after absolute HZZ measurement in e^+e^-)
- Higgs-self coupling can be measured with $\delta\kappa_\lambda(\text{stat}) \approx 5\%$ precision at FCC-hh (best achievable precision among all future facilities)
- **VBS** longitudinal polarisations $\mathbf{V}_L\mathbf{V}_L$ can be measured at **3-4%** precision (W_LW_L same sign), provides percent level precision HWW coupling measurement.
- Can directly and indirectly exclude compelling classes of models compatible with 1st order electro-weak phase transition
- Extremely rich Higgs program at the FCC-hh, goes much beyond what has been presented here.
- Further studies are needed:
 - gauge boson pair production at large mass (to study anomalous couplings)
 - differential measurements: Higgs p_T in the multi-TeV, as a probe of BSM physics
 - VH production at large mass
 - missing HH decay channels ($bb\tau\tau$ ($\sim 8\%$), $bbbb$, etc ...) and combination

e.g. Charged Higgs Boson?

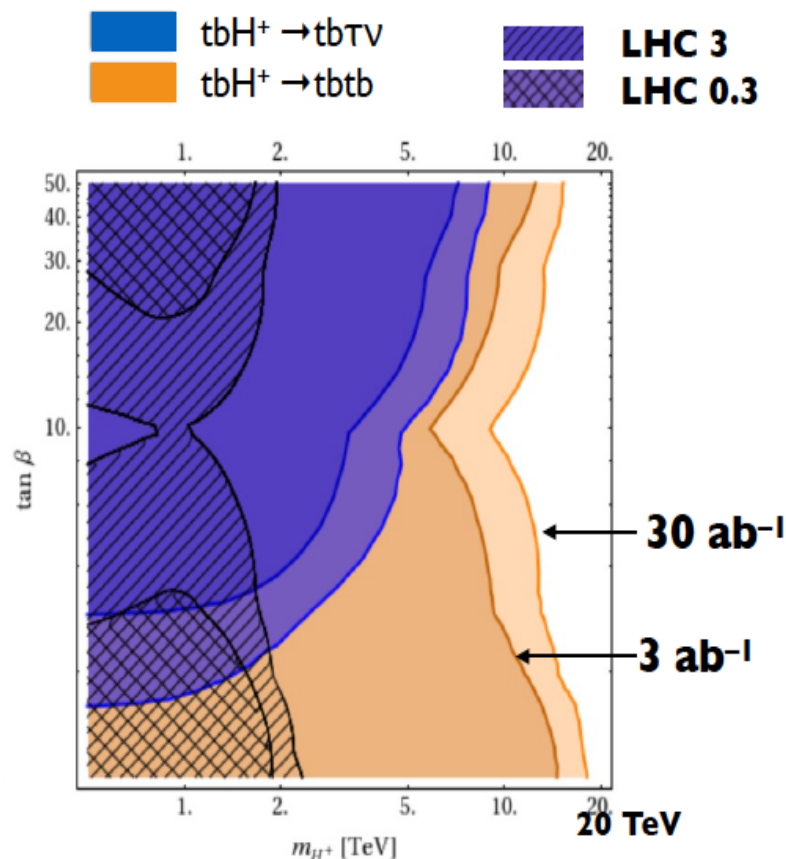

J. Hajer, Y.-Y. Li, T. Liu, and J. F. H. Shiu,
arXiv:1504.07617

Higgs Compositeness?

- Using fits from EWK/Higgs group ([arXiv:1905.03764](https://arxiv.org/abs/1905.03764))

- Connection between notations:

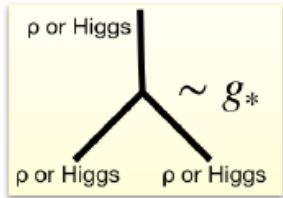

$$\frac{c_\phi}{\Lambda^2} = \frac{g_*^2}{m_*^2}$$

$$\frac{c_W}{\Lambda^2} = \frac{1}{m_*^2}$$

$$\frac{c_{2W}}{\Lambda^2} = \frac{1}{g_*^2 m_*^2}$$

A diagrammatic equation showing a horizontal line labeled "gauge" with a vertical line labeled "ρ" attached to its center. This is followed by a tilde symbol and a fraction: $\frac{g_W}{g_*}$.

- Deviations ~1% in Higgs couplings for mass/coupling ~2 TeV

95% CL limits on compositeness scale (O_H operator)

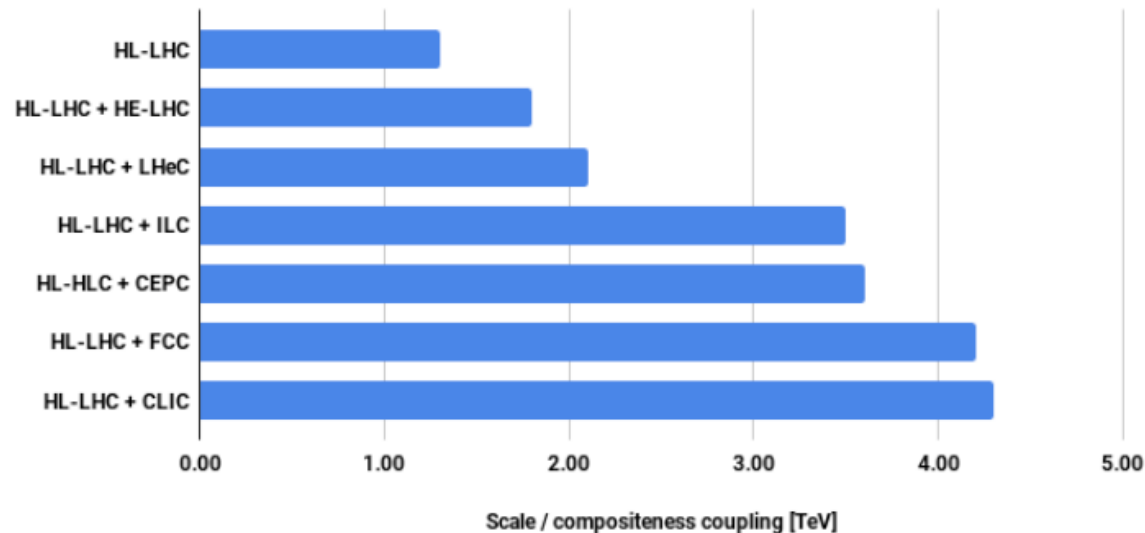

Maximum sensitivities from CLIC and FCC(ee+eh+hh)

Note:

HL-LHC reaches 1.2 TeV

with LHeC 2.1 TeV

e+e- colliders + LHC lead to 3-4 TeV

CLIC here is the 3 TeV Version.

Example for pp+ep+ee Symbiosis.

Future Searches with FCC-pp

Example: Strongly interacting SUSY: Gluinos

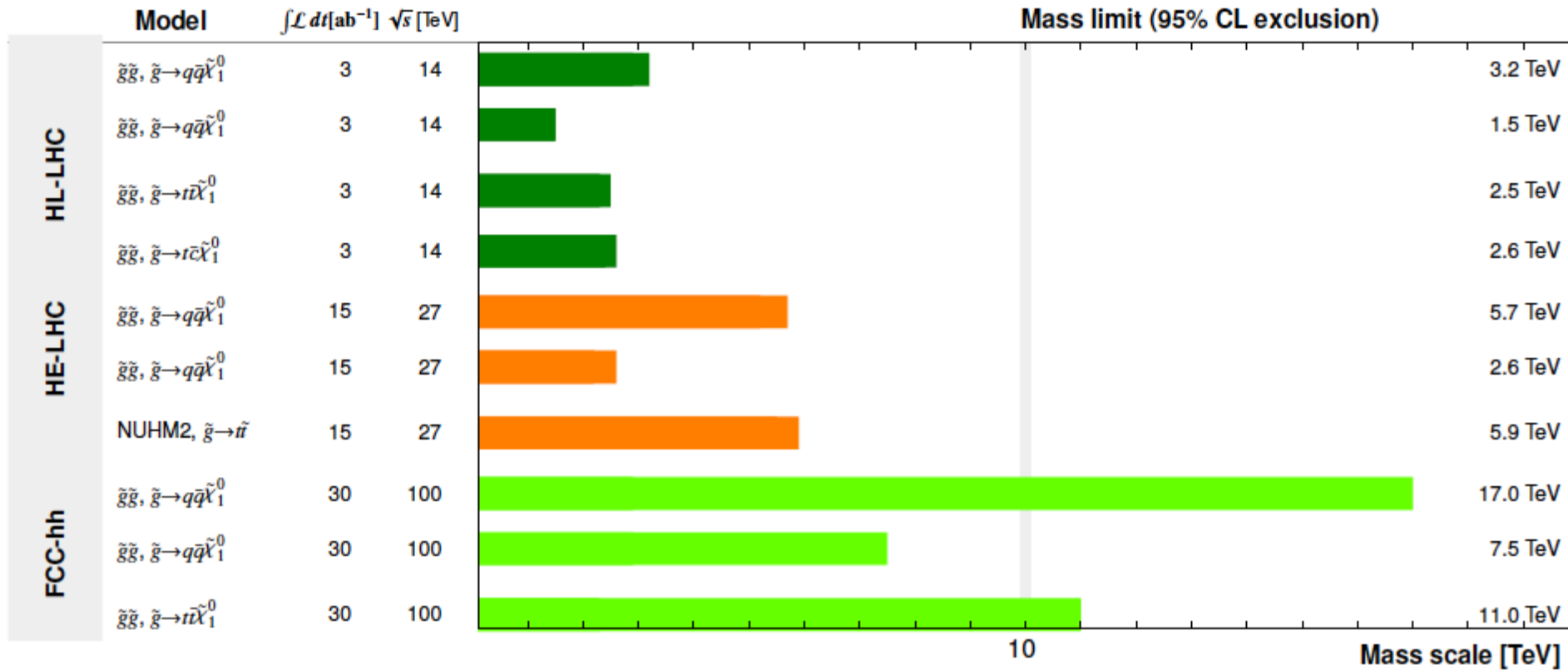

Gian Giudice and Paris Sphicas with BSM WG, Granada, May 2019

FCC-pp unbeatable in its discovery reach, through energy and luminosity. A 40 TeV FCC-pp is in between HE-LHC and 100 TeV

FIPs: Vector Portal (Dark Photon)

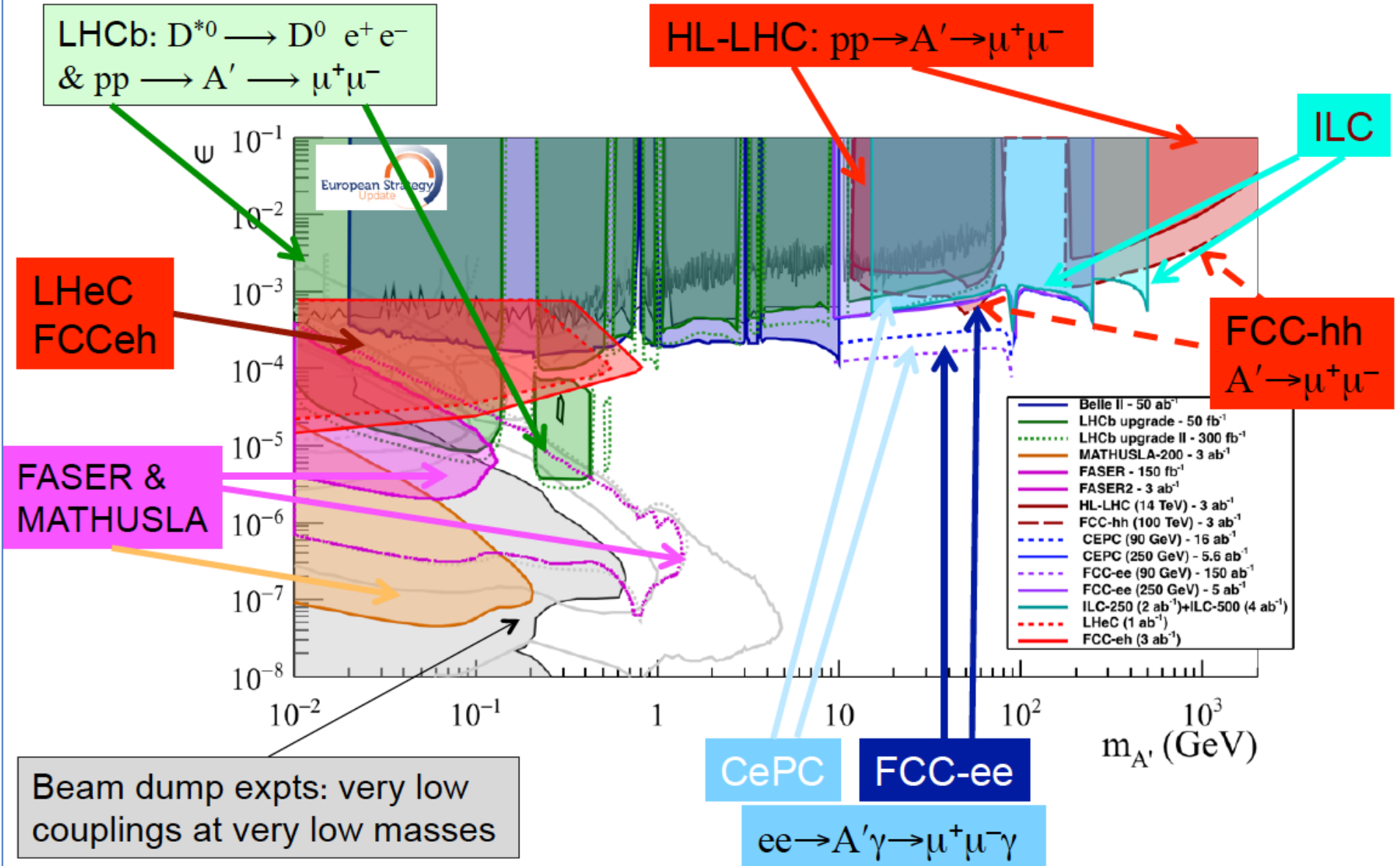

Another example of the complementarity of experiments in the search for new physics.

QCD with FCC-pp

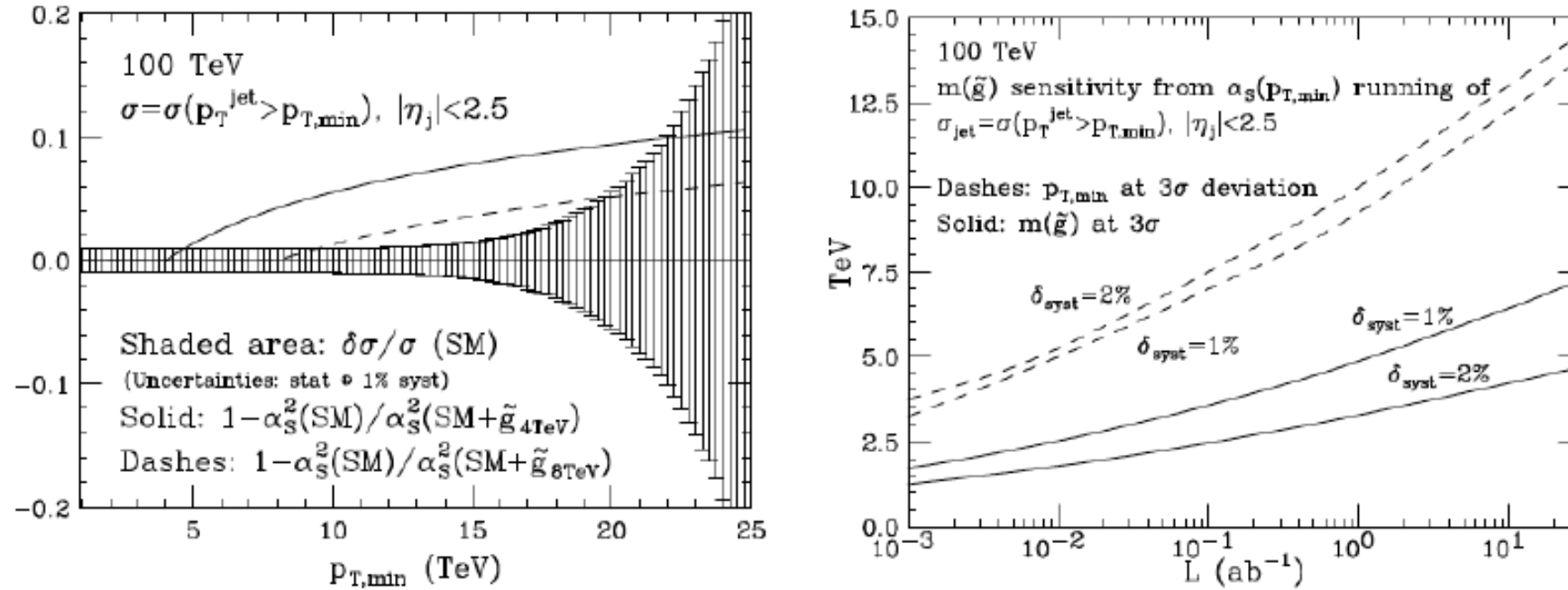

Figure 5.5: Left plot: combined statistical and 1% systematic uncertainties, at 30 ab^{-1} , vs p_T threshold; these are compared to the rate change induced by the presence of 4 or 8 TeV gluinos in the running of α_S . Right plot: the gluino mass that can be probed with a 3σ deviation from the SM jet rate (solid line), and the p_T scale at which the corresponding deviation is detected.

Jet cross sections sensitive to $p_{T,\text{min}}$ of $\sim 20 \text{ TeV}$. Departures in the cross section from 4 or 8 TeV gluinos present in the evolution of the strong coupling at high scales. Study (right) as functions of statistical and systematic error. Precision inferior to eh/ee.

Example:

Strong coupling
sensitivity to gluinos

Jets

QCD at FCC

M.K. Presentation of CDR
March 2019, CERN

Principal Components for QCD



Hot & Dense QCD

A coherent and complementary “hot & dense QCD program” at the SPS brings valuable and unique contributions in the exploration of the QCD phase diagram.

An (HL-HE-)LHC/FCC based AA/pA/fixed-target program is unique and provides essential science at the frontline towards a profound understanding of particle physics.



Precision QCD

A globally concerted “precision QCD program” provides a unique avenue to find new physics that breaks the Standard Model.

A high-luminosity e^+e^- collider at the EW scale and a high-energy ep collider provide a unique environment for high-precision QCD, essential for most of our aspirations in particle physics.



Partonic Structure

A “hadronic structure program” exploring the complementarity of ep/pp/eA colliders provides vital ingredients for the high precision exploration in searches for new physics and as well steps into uniquely unknown territories of QCD.



Theory

It is vital to support coherently the QCD theory community to succeed in all these programs and to link QCD to the rest of the particle physics research program, especially for our HL-LHC exploration.



Organization

Strengthening the synergies in research and technology with adjacent fields will reinforce our efforts.

Global platforms, networks and institutes have the potential to enhance the research exchange among experts worldwide and to provide essential training opportunities.

LHC (HL+HE) Footprint of ERL FCC

LHeC
 50 GeV
 5km tunnel
 1 TeV cms
 10^{34} Lumi
 $O(1) ab^{-1}$
 IP2

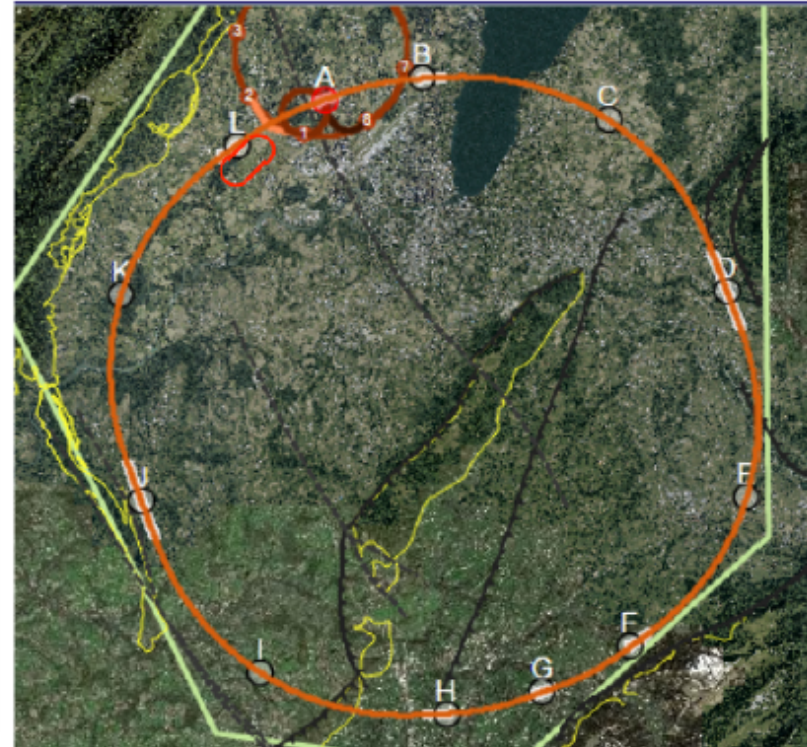

FCC-eh
 60 GeV
 9km tunnel
 3 TeV cms
 10^{34} Lumi
 $O(2) ab^{-1}$
 Point L

Figure 2: Possible locations of the ERL racetrack electron accelerator for the LHeC (left) and the FCC-he (right). The LHeC is shown to be tangential to Point 2 and Point 8. For Point 2 three sizes are drawn corresponding to a fraction of the LHC circumference of 1/3 (outer, default with $E_e = 60$ GeV), 1/4 (the size of the SPS, $E_e = 56$ GeV) and 1/5 (most inner track, $E_e = 52$ GeV). To the right one sees that the 8.9km default racetrack configuration appears to be rather small as compared to the 100 km ring of the FCC. Present considerations suggest that Point L may be preferred as the position of the ERL, while two GPDs would be located at A and G.

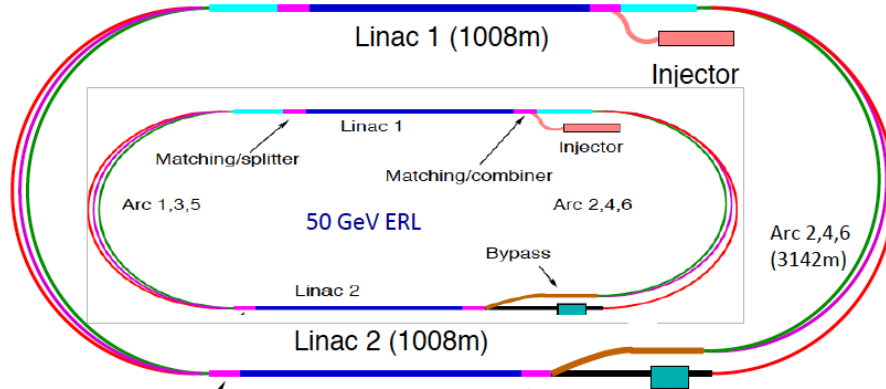

LHeC: 1 TeV ep collider with 10^{34} luminosity: P/10! Dump at injection.
Possible injector to FCC-ee in recirculating mode [O.Brueening]

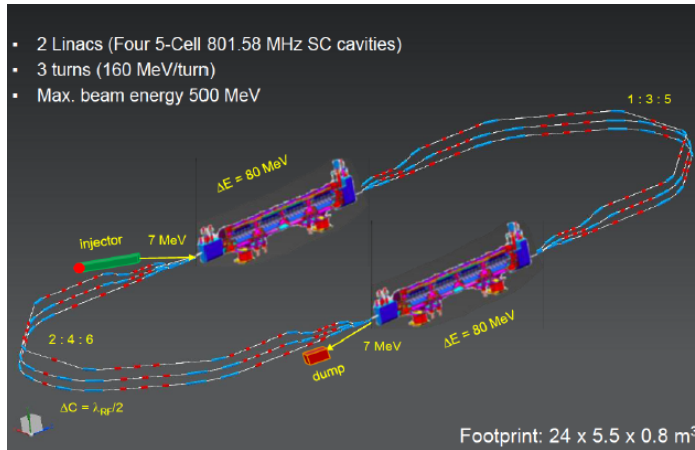

ERL: A revolutionary technology ripe for real applications in HEP, low energy and industrial areas, of huge potential just evolving : to be recognised in strategy

Energy Recovery

today and tomorrow

FCC-ee

- Joint 802 MHz cavity development [LHeC+FCC]
- Complete Design of FCC-ee with ERL technique: [extension to higher energy, less SR power, higher lumi > WW]

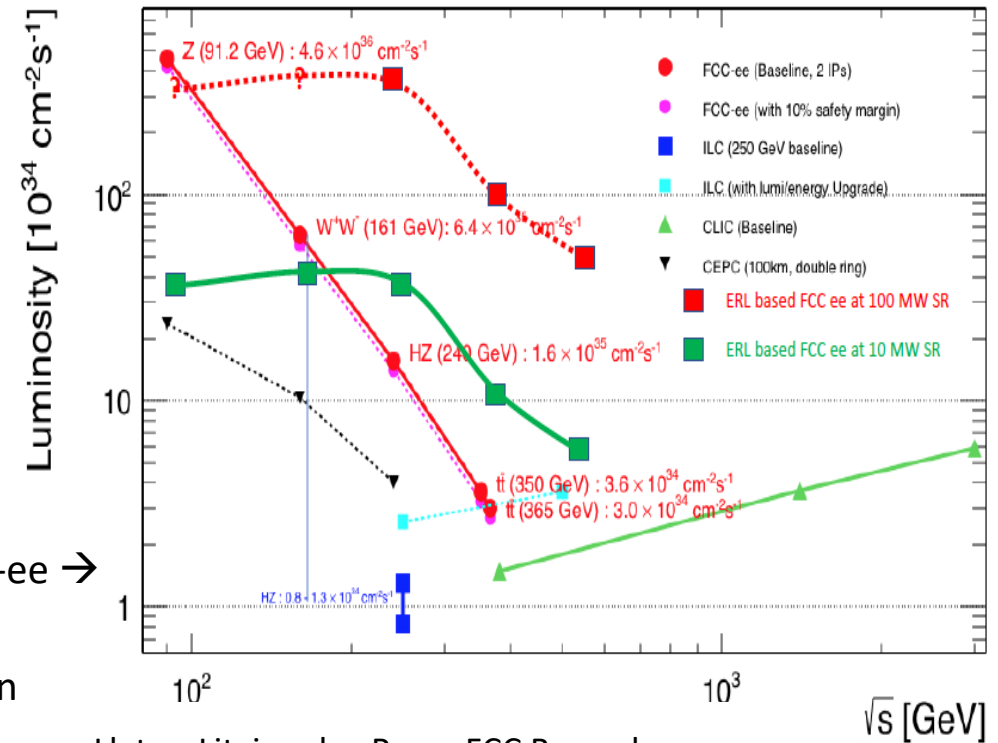

Llatas, Litvinenko, Roser FCC Brussels

PERLE BINP, CERN, Daresbury, Liverpool, Jlab, Orsay+. Could be 6 GeV injector to FCC-ee →
ERLs in: Berlin, BINP, Cornell, Daresbury, Darmstadt, Jlab, KEK, Mainz..
High current and $E \sim 1\text{GeV}$: low energy physics [1000 x L(ELI)!], lithography, photofission

Physics with Energy Frontier DIS

Deep Inelastic Scattering

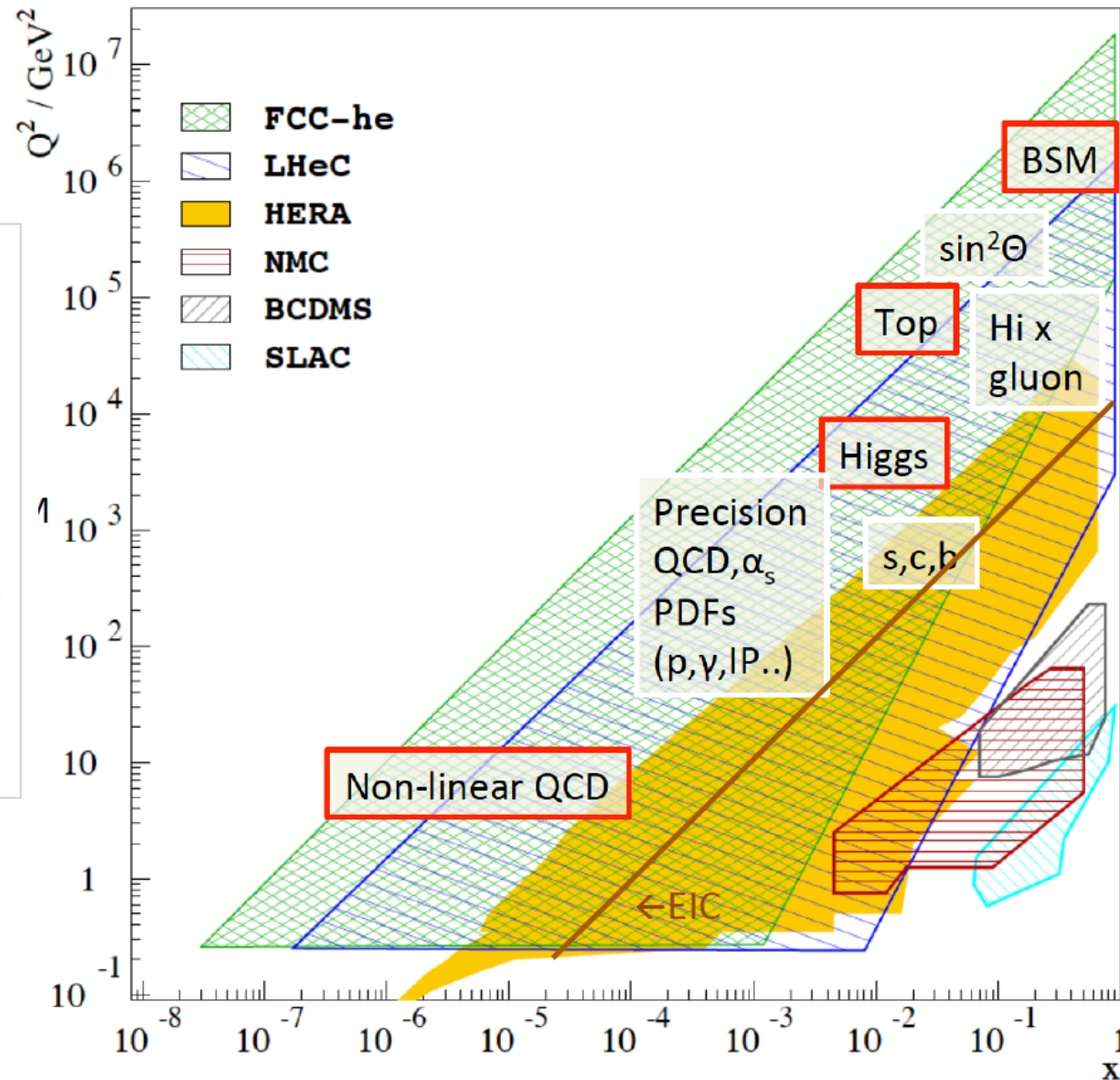
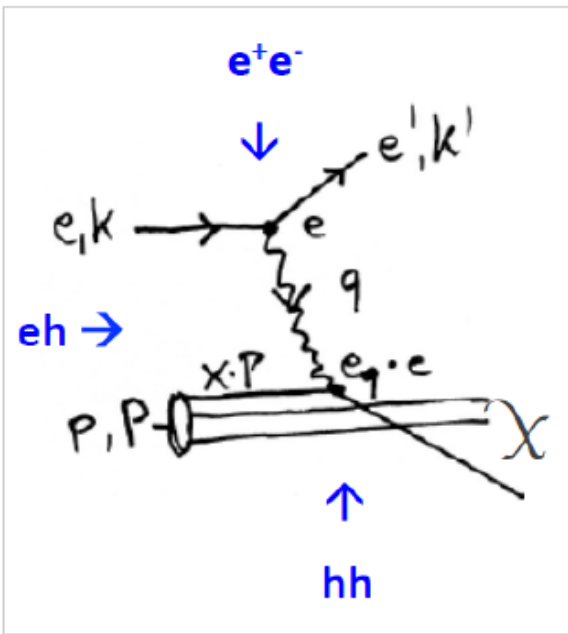

Raison(s) d'être of the LHeC

Cleanest High Resolution Microscope: QCD Discovery

Empowering the LHC Search Programme

Transformation of LHC into high precision Higgs facility

Discovery (top, H, heavy ν 's..) Beyond the Standard Model

A Unique Nuclear Physics Facility

Parton Distributions

DIS: clean theory, light cone, redundant e/h FS reconstruction, ..

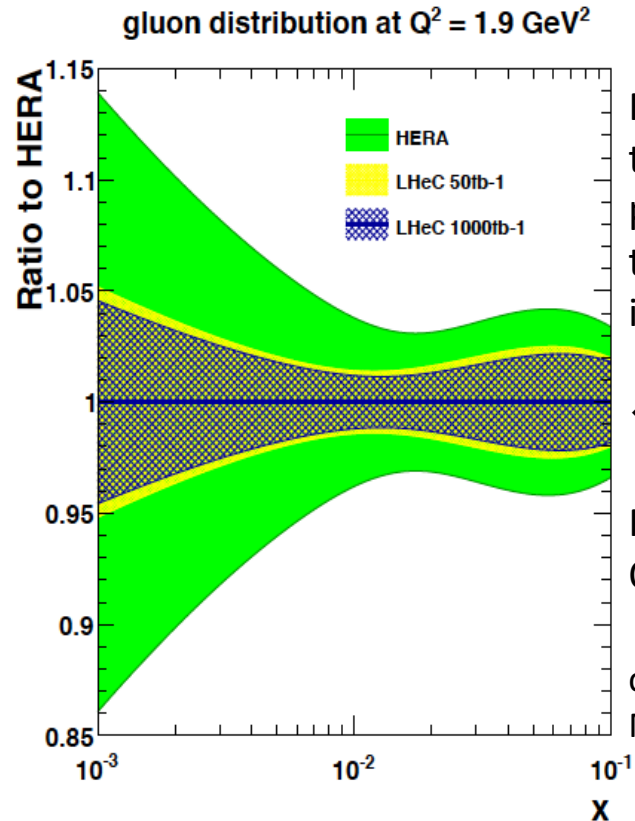

For LHC to have an impact on the search and precision physics program at HL-LHC it is crucial that PDF and QCD information is available early.

← PDF study with 50 vs 1000 fb^{-1}

Remove essential part of QCD uncertainties of $gg \rightarrow H$

cf C. Gwenlan, talk at DIS19 and M Cooper Sarkar yesterday at EPS

Figure 6: Uncertainty on the determination of the gluon distribution in the x range relevant for Higgs measurements at the LHC, based on the combined HERA data (outer band, green) and for the LHeC with the full data set (inner band, blue) and from the first running period (yellow, around the inner band). The LHeC uncertainties comprise full correlated systematic error estimates besides the statistics.

Note that 50fb^{-1} is 100 times H1's total luminosity: Low x needs just 1fb^{-1} .

Complete unfolding of parton contents in unprecedented kinematic range: u, d, s, c, b, t, xg
Strong coupling to permille accuracy (incl + jets):

Crucial for LHC:

- high precision eweak, Higgs measurements
- Extension of high mass search range
- Non-linear low x parton evolution; saturation?

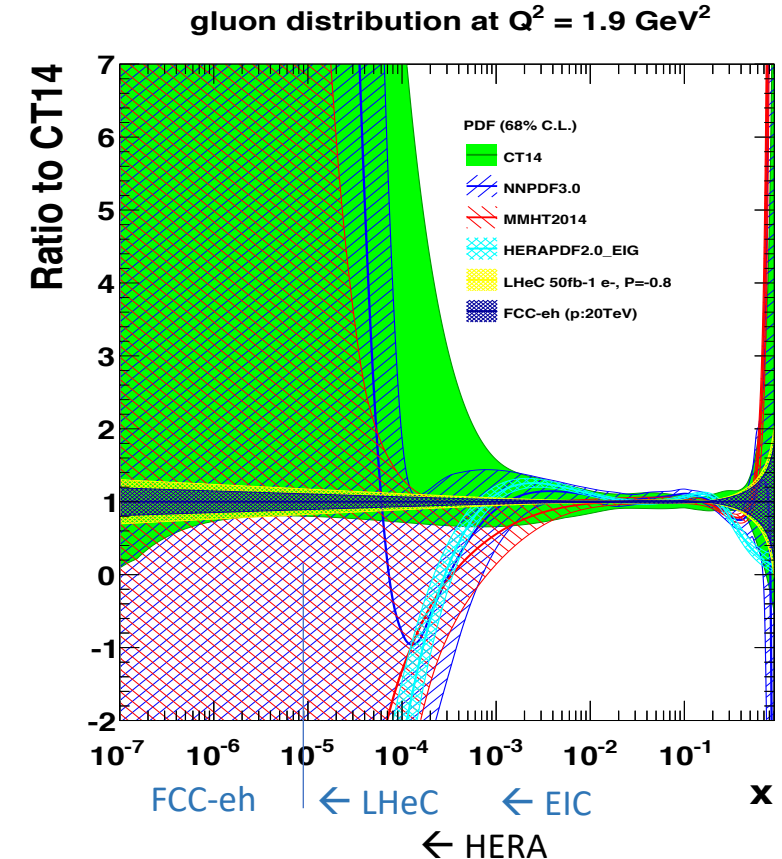

Higgs in ep and pp [LHeC and HL-LHC]

Determination of SM Higgs couplings jointly from pp + ep

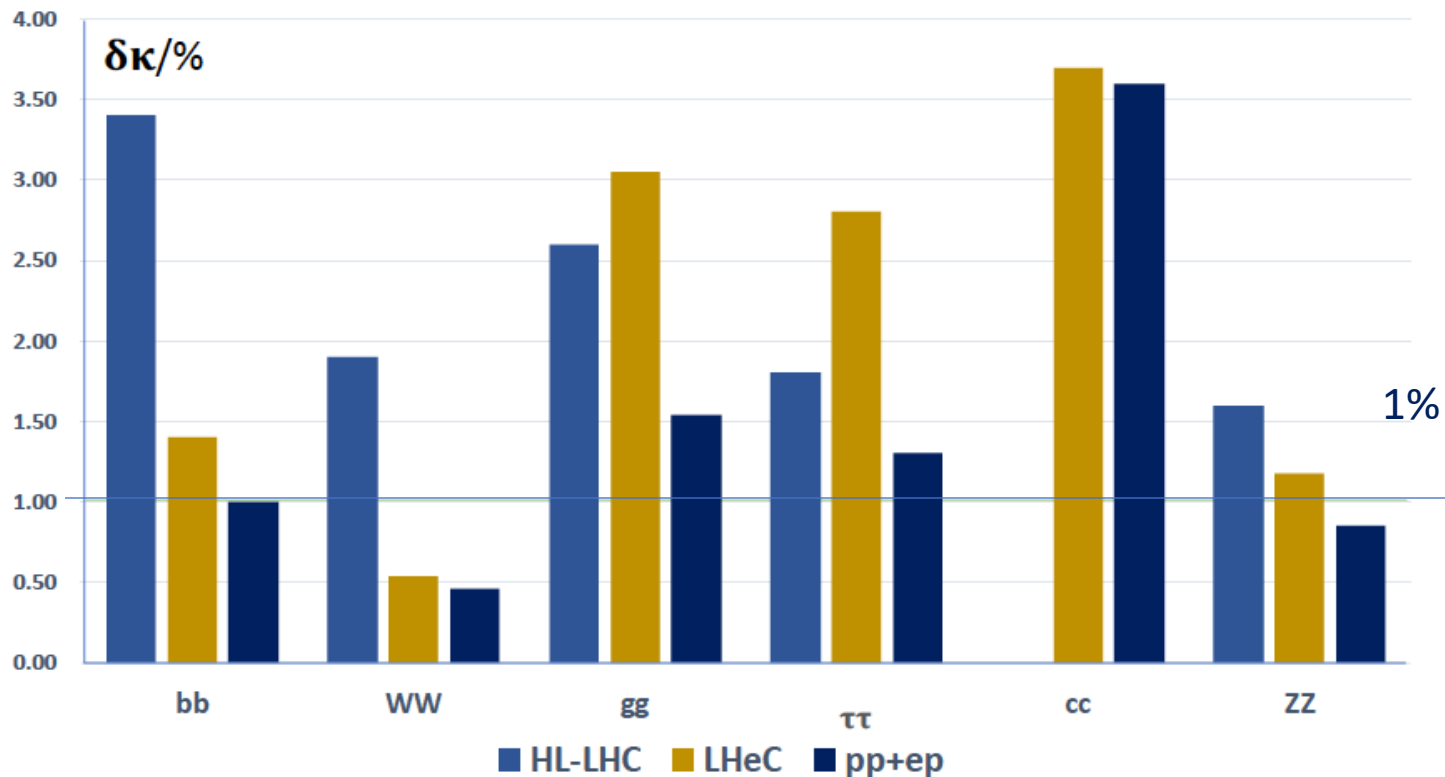

The combined ep+pp at LHC reaches below 1% for dominant channels
ep adds charm. Analysis in EFT framework work in progress (aTGCs in ep..)

Results for FCC-eh at
20 TeV E_p x 60 GeV E_e

Uncertainties on kappa
Decay FCCep HL-LHC

bb	0.9	2.7
WW	0.3	1.2
gg	1.7	2.2
tau	1.5	1.6
cc	1.9	--
ZZ	0.5	1.0
yy	3.3	1.7

in percent. SM width.

Precision
Electroweak
Physics

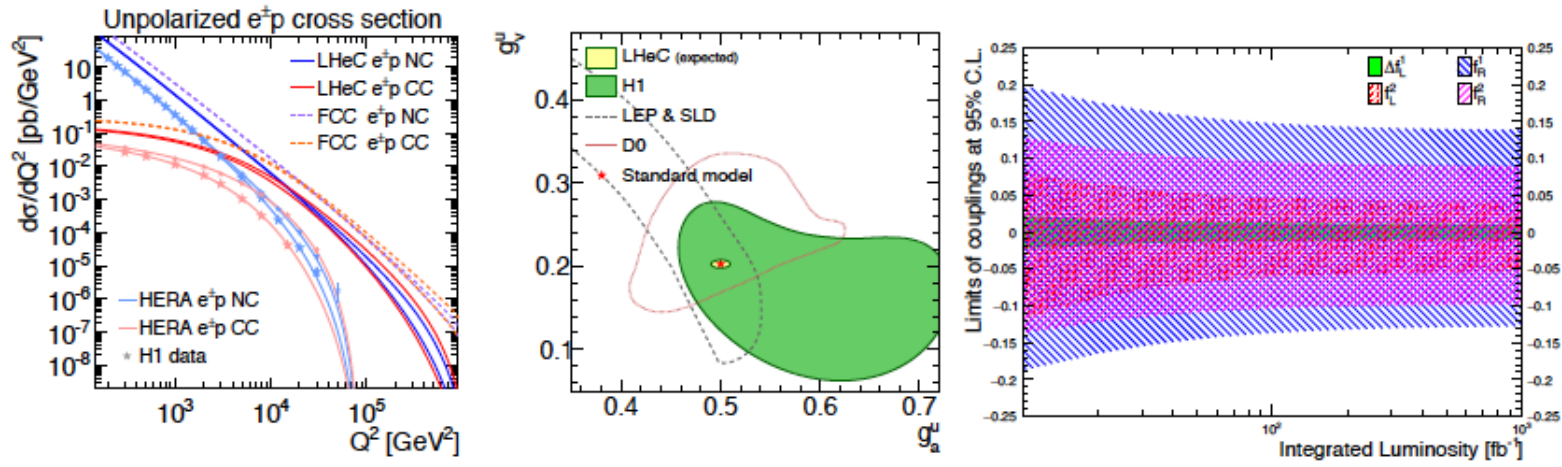

Electroweak+Top Physics

Figure 1: Left: Unpolarised inclusive NC and CC DIS cross sections as a function of Q^2 at the LHeC, in comparison to HERA (H1 [17]) and FCC-eh expectations; Middle: Determination of the up-quark weak neutral current vector and axial-vector couplings with LHeC (yellow) compared with current determinations; Right: Expected sensitivities as a function of the integrated luminosity on the SM and anomalous W_{tb} couplings [18].

Anomalous
 W_{tb} couplings

Heavy Neutrinos

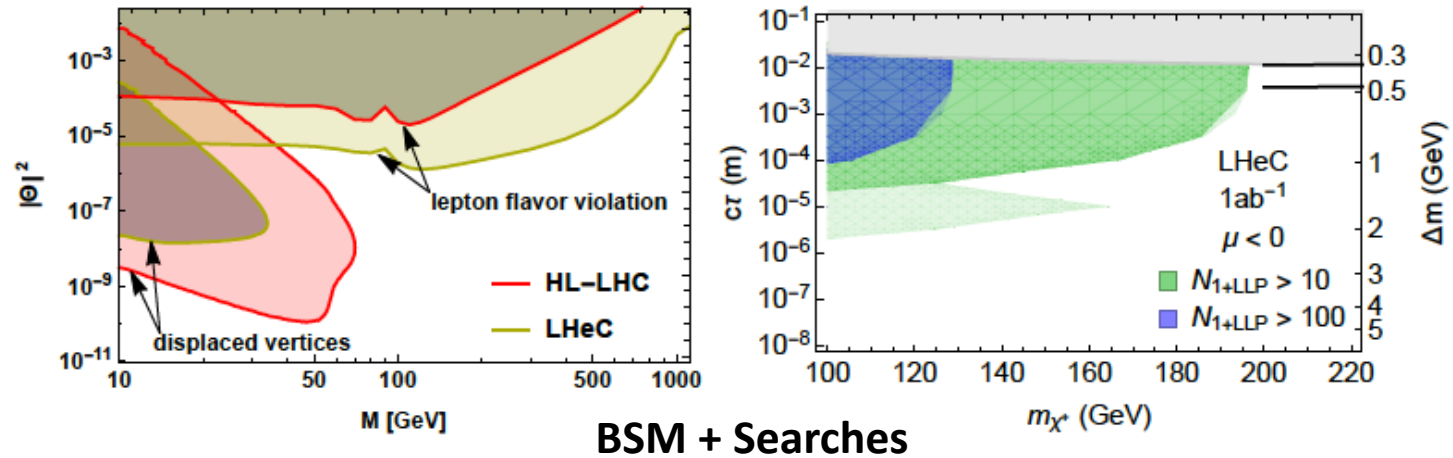

BSM + Searches

Figure 4: Left: Prospects for direct right-handed neutrino searches at the LHeC, first estimates for HL-LHC prospects for comparison, based on [34]. Right: Reach for long-lived Higgsinos in the mass (m_χ) - lifetime ($c\tau$) plane, compared to disappearing tracks at the HL-LHC [35], shown by the black lines. Light shading indicates the uncertainty in the predicted number of events due to different hadronization and LLP reconstruction assumptions. For details, see [36].

Higgsinos

Unique nuclear/HI physics programme
 Extension of fixed target range by 10^{3-4}
 QCD of QGP, de-confinement, saturation..
 nPDFs independent of p PDFs

High
 luminosity
 $\sim 10^{33}$
 enables
 high statistics
 in short
 eA runs
 cf J Jowett et al

present
 status \rightarrow
 on xg
 Pb/p

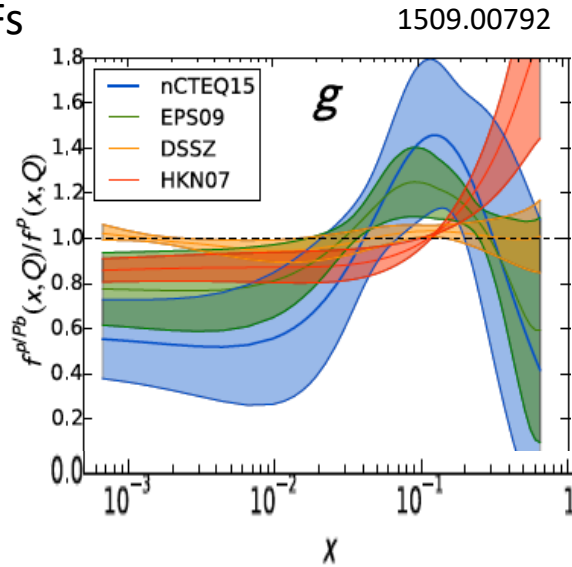

Nuclear PDFs at LHeC/FCCeh

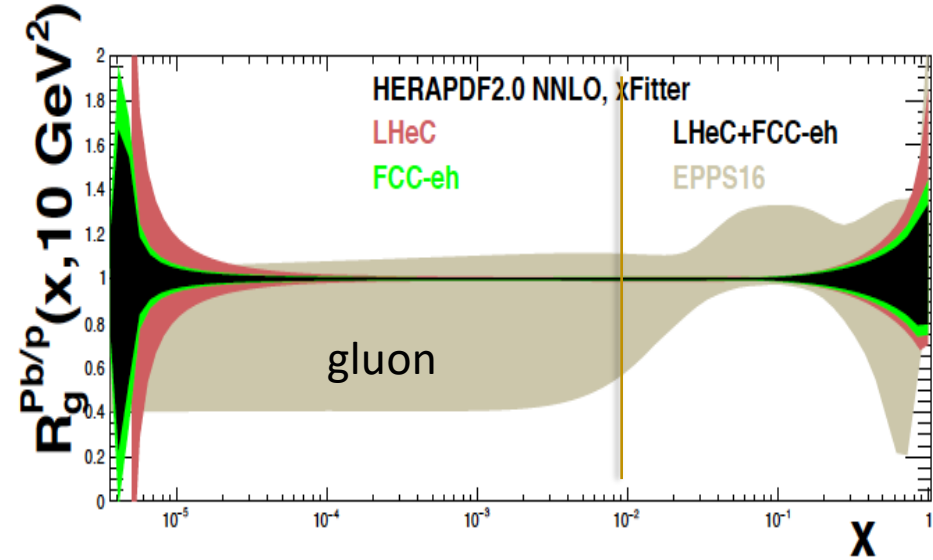

N Armesto, FCC Physics Week 1/2018

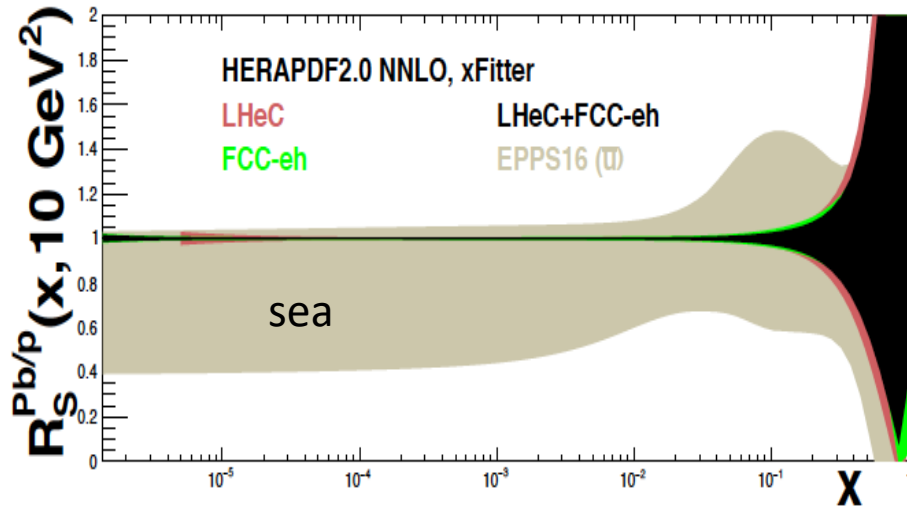

LHeC: Full error, $\Delta\chi^2=1$. EPPS $\Delta\chi^2=52$

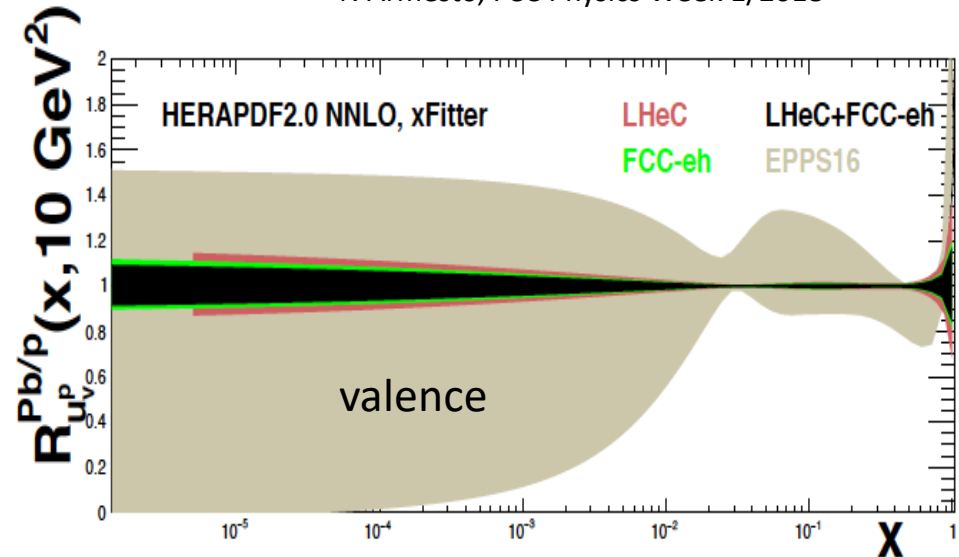

cf talk by
 A Stasto today

LHeC Detector

L=13.6 m [FCCeh:19.3 about CMS size]

R=4.6 m
[6.2 FCCeh]

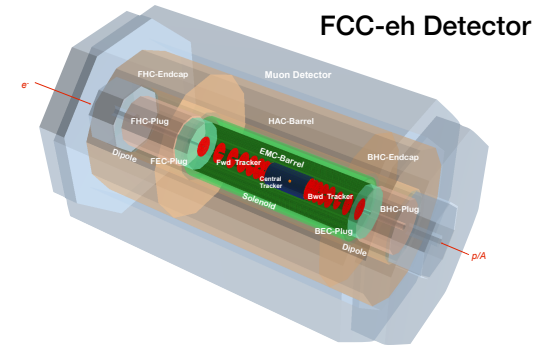
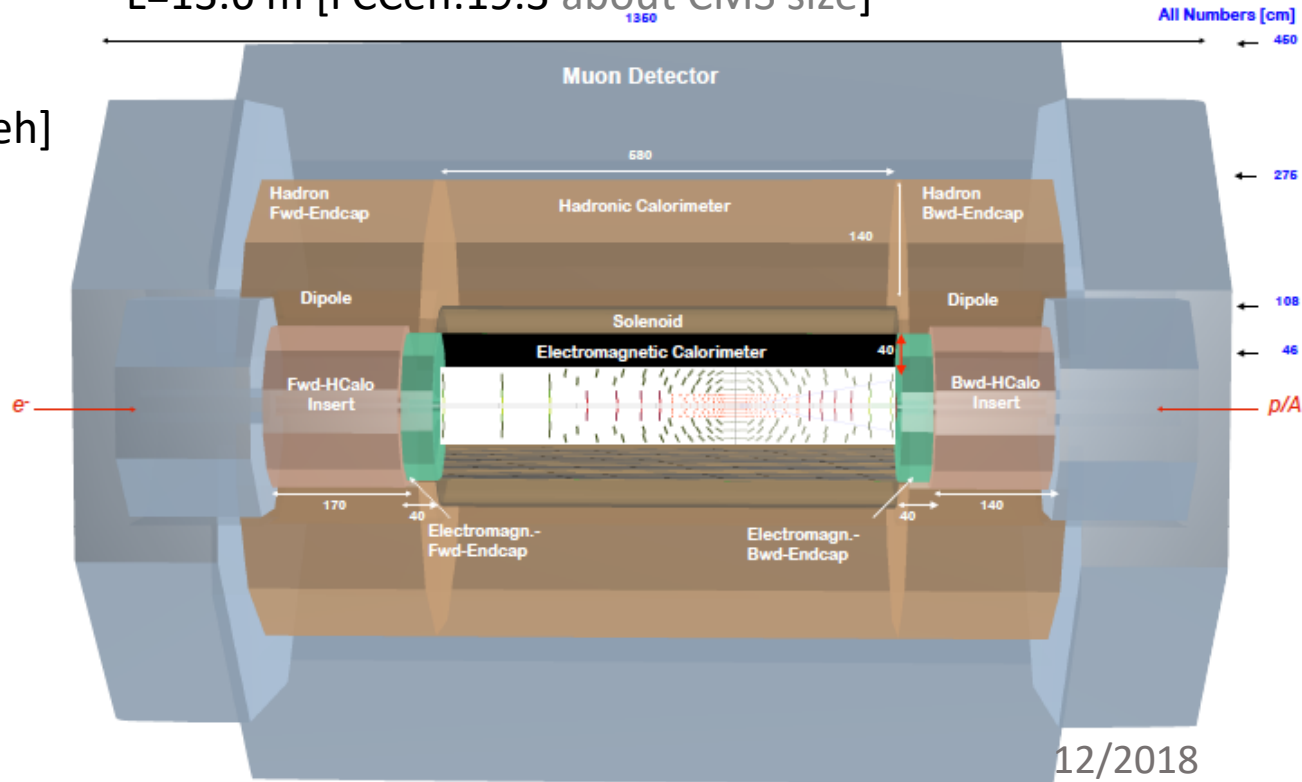

Study of installation (sequence) of LHeC detector in IP2 cavern using L3 magnet support structure [commensurate with 2 year shutdown] A. Ghaddi et al, LHeC Workshop 2015

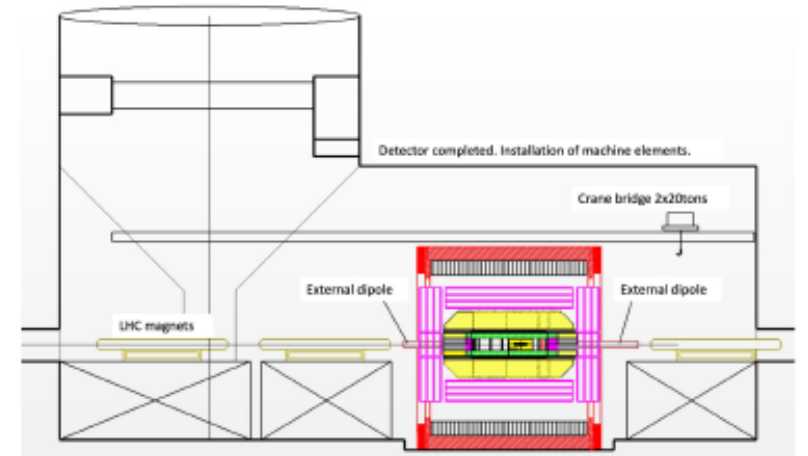

Figure 2: Current status of the LHeC central detector design. The detector is complemented by photon and electron taggers in the electron beam direction and by proton and neutron tagging forward spectrometers as were presented in the CDR [1].

Currently: increase radius of tracker, choose technology, summarise/simulate response: update this fall

FCC-eh in the CDR [V1 Physics and V3 hh]

Volume 1 had been the collaborative effort to present **the entity of FCC physics, in ee, pp and ep, including AA and eA**
Volume 3 on FCC hh contains a short summary of **the main characteristics of FCC-eh and the detector concept**

Some striking physics eh prospects are on searches and the high precision measurements on Higgs and proton structure:

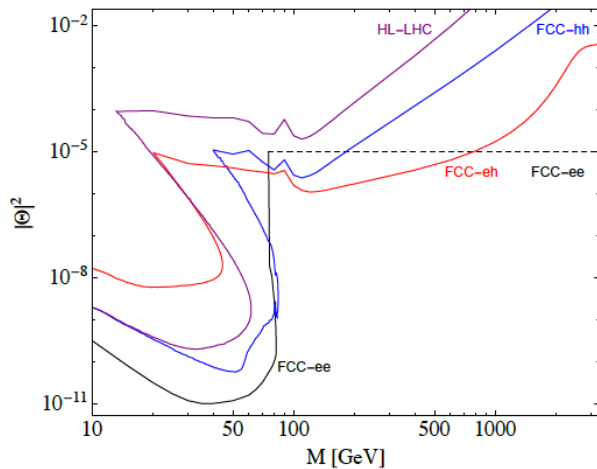

Complementary prospects to **discover rh massive neutrinos** in ee, ep and pp
 [mixing angle vs mass]

Collider	FCC-ee	FCC-eh
Luminosity (ab^{-1})	+1.5 @ 365 GeV	2
Years	3+4	20
$\delta\Gamma_H/\Gamma_H$ (%)	1.3	SM
$\delta g_{HZZ}/g_{HZZ}$ (%)	0.17	0.43
$\delta g_{HWW}/g_{HWW}$ (%)	0.43	0.26
$\delta g_{Hbb}/g_{Hbb}$ (%)	0.61	0.74
$\delta g_{Hcc}/g_{Hcc}$ (%)	1.21	1.35
$\delta g_{Hgg}/g_{Hgg}$ (%)	1.01	1.17
$\delta g_{H\tau\tau}/g_{H\tau\tau}$ (%)	0.74	1.10
$\delta g_{H\mu\mu}/g_{H\mu\mu}$ (%)	9.0	n.a.
$\delta g_{H\gamma\gamma}/g_{H\gamma\gamma}$ (%)	3.9	2.3
$\delta g_{Htt}/g_{Htt}$ (%)	—	1.7
BR_{EXO} (%)	< 1.0	n.a.

Prospects for high precision measurements of **Higgs couplings at FCC ee and ep**. Note ee gets the width with Z recoil. ee is mainly ZHZ, while ep is mainly WWH: complementary also to pp

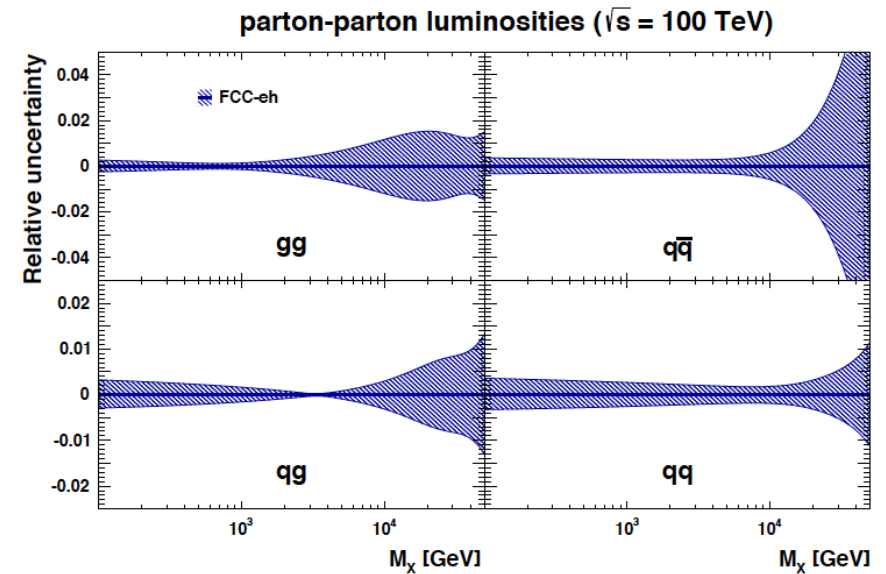

Unique resolution of partonic contents of and dynamics inside the proton, providing precise and independent parton luminosities for interpretation and searches on FCC-hh

Possible scenarios of future colliders

- Proton collider
- Electron collider
- Electron-Proton collider
- Construction/Transformation
- Preparation

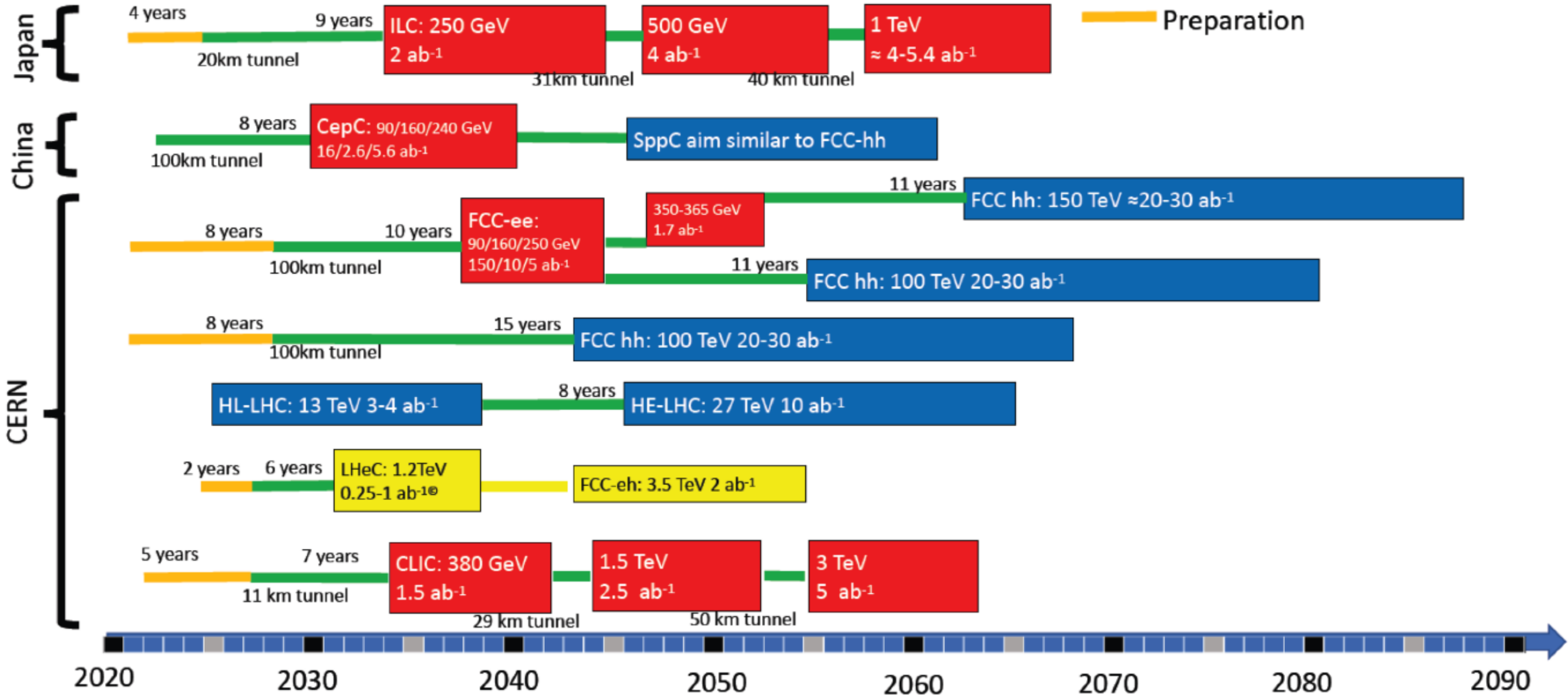

Concluding Remarks

The LHC has only seen 5% of its anticipated luminosity. The total cost of its HL upgrade is near to 2 BSF.

The exploitation of the LHC is the prime task of PP. The LHeC is the ideal complement to sustain the 30ies.

The FCC-pp collider is the only future collider which may change the paradigm of PP. Its 100 TeV version is currently beyond financial and technology reach (Nb_3Sn high field dipoles?). It therefore is worth to seriously consider building a 40 TeV (cms) hadron collider at CERN, with LHC magnet technology in 2040+, especially if Asia eventually decides to build a next e^+e^- collider.

The physics programme of the FCC-pp builds on the LHC. If there is no further physics, even at 10 TeV energies, it yet has a fundamental goal, which is the understanding of the Higgs potential, it cannot fail.

The addition of an ERL electron beam makes the FCC physics richer, very precise, reliable and adds to the discovery potential in QCD and electroweak physics, potentially beyond, including nuclear structure.

Energy recovery becomes a realistic means, no less important than plasma, to revolutionise accelerator technology (under design for ep, under consideration for FCCee, under construction for low energy physics and applied facilities such as PERLE at Orsay, MESA at Mainz and possibly DIANA at Daresbury).

backup

CERN-ACC-NOTE-2018-0084
December 18, 2018



Exploring the Energy Frontier with Deep Inelastic Scattering at the LHC
A Contribution to the Update of the European Strategy on Particle Physics

LHeC and PERLE Collaboration

LHeC also described in the ES paper by A.Caldwell, A.Levy, R.Ent, P.Newman and F.Olness

Summary
Papers
submitted
to the
European
Strategy
12/2018

CERN-ACC-NOTE-2018-0086

December 18, 2018



PERLE : A High Power Energy Recovery Facility for Europe

A Contribution to the Update of the European Strategy on Particle Physics

Cockcroft Institute, AsTEC Daresbury, TU Darmstadt, BINP Novosibirsk, CERN, Liverpool University,
IPN and LAL Orsay, Jefferson Laboratory, CEA Saclay

Higgs Mass and Potential

The **Higgs mass is subject to vacuum corrections** (loops with q, l, H and W, Z parts)

These corrections are quadratically divergent. Recall: the W was introduced to remove the divergence of the $2 \rightarrow 2$ fermion scattering cross section. The Higgs is introduced to remove the divergence of the $ff \rightarrow WW$ cross section. Now we seem to **need something to keep the Higgs mass finite.**

SM: Incredible fine tuning of parameters [Hierarchy problem]

Technicolour: Higgs not elementary but composite at a scale of 1 TeV would introduce a cut-off to loop corrections. At this scale the ‘weak interactions become strong’ . [Susskind et al.]

SUSY: cancel divergencies by introducing partners for ALL particles with same quantum numbers and identical couplings, and similar (?) masses