

Future of High Energy Physics

an Experimentalist's, European Perspective

Remarks
Non-collider Physics
Upgrading the LHC
Big Machines

Max Klein
CERN and U Liverpool



Thanks to: Phil Allport, Guido Altarelli, Nestor Armesto, Sergio Bertolucci, Johannes Bluemlein, Frederick Bordry, Themis Bowcock, Oliver Brüning, Anadi Canepa, John Dainton, Monica D'Onofrio, Lau Gatignon, Tim Greenshaw, Peter Jenni, Erk Jensen, Uta Klein, Peter Kostka, Bela Majorovits, Bruce Mellado, Steve Myers, Tatsuya Nakada, Paul Newman, Fred Olness, John Osborne, Jim Pilcher, Voica Radescu, Christoph Rembser, Bob Rimmer, Christian Spiering, Steinar Stapness, Herwig Schopper, Daniel Schulte, Alessandra Valloni, Ferdinand Willeke, Frank Zimmermann and many other colleagues for thoughts about the future and also for material for this talk

Invited Talk at DIS 2015, Dallas Texas, 1.5.2015



1st session of CERN Council, 15.2.1952 - Niels Bohr watching us..

Two conditions for prosperity of HEP

Staff

Positions for next generations: CERN staff + visitors: 1960 1166 → 1965 2530

A major new step will depend on how we can keep HEP attractive for life plans.

Accelerators

L.D. Landau:

Accelerators have the advantage to control the initial conditions



Europe's big machines

???

LHC

LEP, HERA

SppS, PETRA

SPS

time

Accelerators need sites and major institutions. CERN should better have strong European partners DESY, Frascati, RAL, Saclay,.. and global challenges too.

Funding HEP



E.Amaldi to ECFA, 10.7.1968

In the Council meeting of 19 June, the United Kingdom delegation announced the decision of the British Government not to participate in the 300 GeV project. This decision was essentially based on economical considerations; the scientific and technical merits of the project were not questioned. The British delegate added a personal statement endorsed by the competent scientific authorities in his country in which as a physicist he regretted the decision of his Government and hoped that it would be possible at a later time to come back on it.

convincing us and the academic and public society – necessary, not always sufficient

Time Projections

Scientific activities

European Strategy 2006

3. The LHC will be the energy frontier machine for the foreseeable future, maintaining European leadership in the field; *the highest priority is to fully exploit the physics potential of the LHC, resources for completion of the initial programme have to be secured such that machine and experiments can operate optimally at their design performance. A subsequent major luminosity upgrade (SLHC), motivated by physics results and operation experience, will be enabled by focussed R&D; to this end, R&D for machine and detectors has to be vigorously pursued now and centrally organized towards a luminosity upgrade by around 2015.*

Most likely, the LHC will have been the main base for HEP for ~50 years...

Apparently we are unable to deliver reliable time projections
... and yet we need optimism in order to progress ...

*“The future belongs to those who believe
in the beauty of their dreams.”*

Anna Eleanor Roosevelt
(1884-1962)



Universal Declaration of Human Rights (1948)

cited by Frank Zimmermann at the FCC Meeting at Washington DC, March 2015

Non-collider Physics

Dark Matter

Astro-particle Physics

Fixed Target at CERN

Neutrinos

Upgrading the LHC

Luminosity

Electrons

The Big Machines

ILC, CLIC, CepC, FCC-ee

FCC [hh-he]

A subset of a huge spectrum

- **WIMP** (EW naturalness, WIMP miracle)
- **Axion** (strong CP problem)
- **Sterile ν** (ν mass, desert from M_{top} to M_{p})
- **Gravitino** (supergravity)
- **Asymmetric** ($\Omega_{\text{DM}} \sim 5 \Omega_{\text{vis}}$)
- **Hidden-sector** (model-building, ...)
- **...others...** (“anomalies”, imagination, ...)

Dark Matter

limits by 2022



In this image, dark matter (blue) has become separated from luminous matter (red) in the bullet cluster. (Image courtesy: Chandra)

<http://www.interactions.org/cms/?pid=1034004>

Direct search experiments

ANAIS, ArDM, ADMX, COUP, CEDEX, PANDA-X, TEXONO, CoGeNT, CDMS, CRESST, DAMA/LIBRA, DARWIN, DEAP, DARKSIDE, EDELWEISS, EURECA, FUNK, KIMS, LHC, LZ, PICASSO, SIMPLE, XENON100, XMASS

Indirect search experiments

AMS, ALPS, ANTARES, BAIKAL, CTA, FGST-LAT, GAPS, HPS, HESS, ICECUBE, IMAX, MAGIC, PAMELA, SK, VERITAS

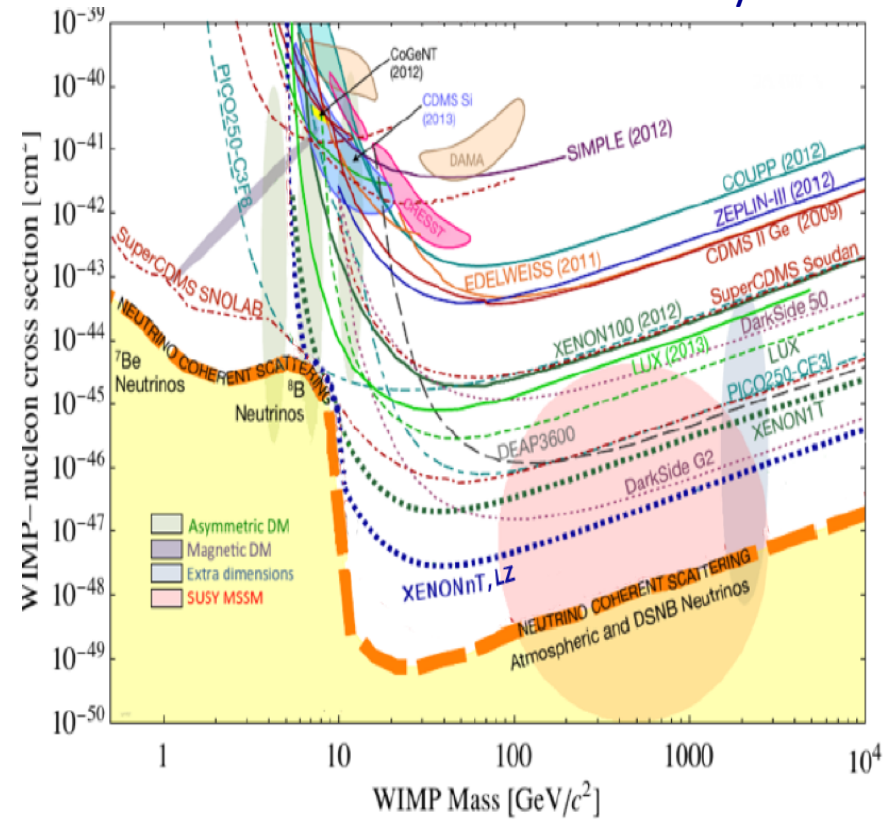

Dark Matter



In this image, dark matter (blue) has become separated from luminous matter (red) in the bullet cluster.
(Image courtesy: Chandra)

<http://www.interactions.org/cms/?pid=1034004>

Direct search experiments

ANAIS, ArDM, ADMX, COUP, CEDEX, PANDA-X, TEXONO, CoGeNT, CDMS, CRESST, DAMA/LIBRA, DARWIN, DEAP, DARKSIDE, EDELWEISS, EURECA, FUNK, KIMS, LZ, PICASSO, SIMPLE, XENON100, XMASS

Indirect search experiments

AMS, ALPS, ANTARES, BAIKAL, CTA, FGST-LAT, GAPS, HPS, HESS, ICECUBE, IMAX, MAGIC, PAMELA, SK, VERITAS

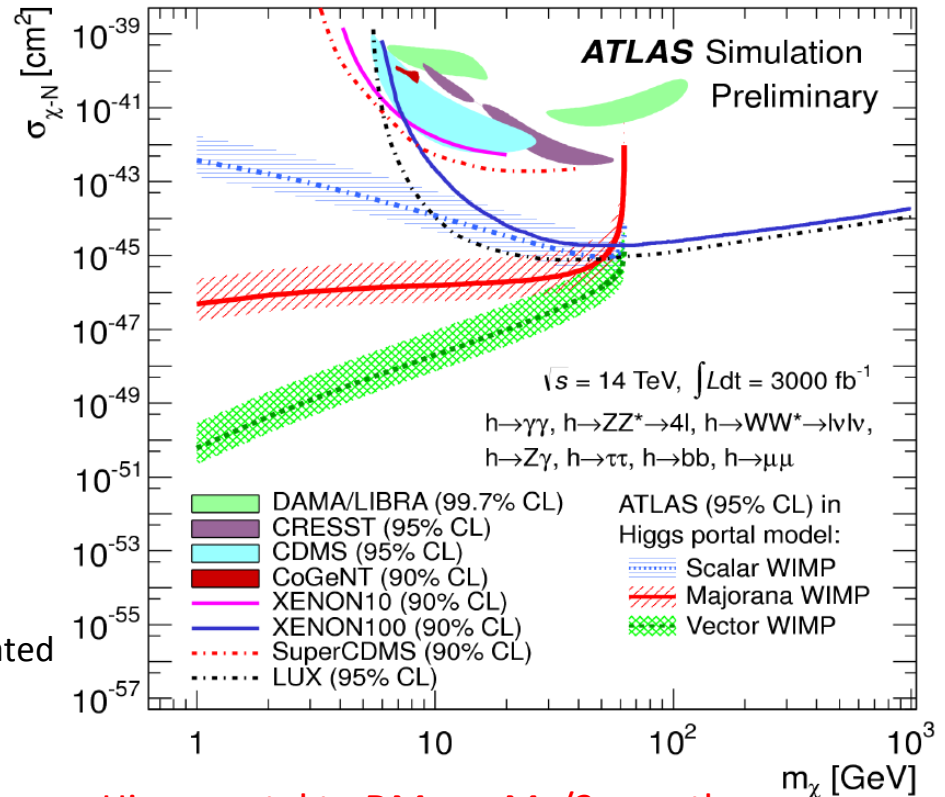

Higgs portal to DM: $m < M_H/2$, mostly

Future High-Energy Astroparticle Physics

- Goals: 1) chart the high energy Universe 2) particle physics
- Recent: detection of cosmic ν with IceCube

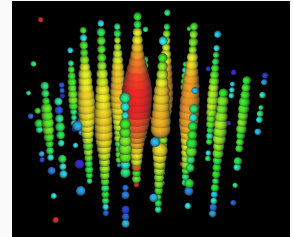

Perspectives:

- Gamma Rays: **CTA**

- South & North;
- sensitivity $\sim 10\times$ H.E.S.S.; extended to lower + higher energies

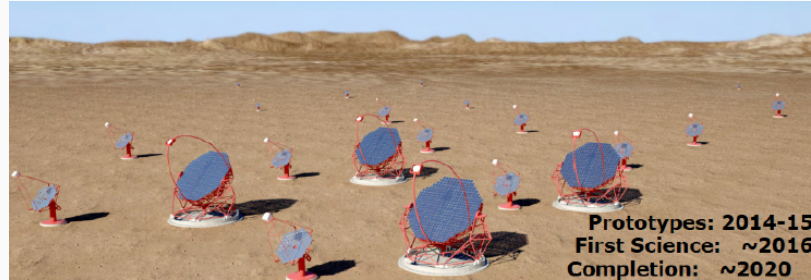

- Charged cosmic rays: **Auger** upgrade

- better determination of mass composition: understand cut-off, start proton astronomy; completion 2017

- Neutrinos: **KM3NeT** and **IceCube-Gen2**

- KM3NeT phase-1 under construction; phase-2 (equiv. to IceCube ~ 2020), includes ORCA to determine NMH; full KM3NeT: mid of 2020s
- IceCube-Gen2: $\sim 10\times$ IceCube, includes PINGU to determine NMH: mid of 2020s. Strong European contribution

Fixed target programme at CERN

PS (Proton Synchrotron) provides protons to

- **East Area**
 - beam tests for detector studies/calibration
 - Irradiation facility for material and electronics studies
 - **CLOUD** experiment (cloud formation by cosmic rays)
- **AD (Antiproton Decelerator)**
 - trapping and experiments with anti-hydrogen
 - Cancer therapy with anti-protons
- **n-TOF (Neutron Time-of-Flight)** facility
 - nucleosynthesis in stars & future high power targets
- **Injector** for **SPS**

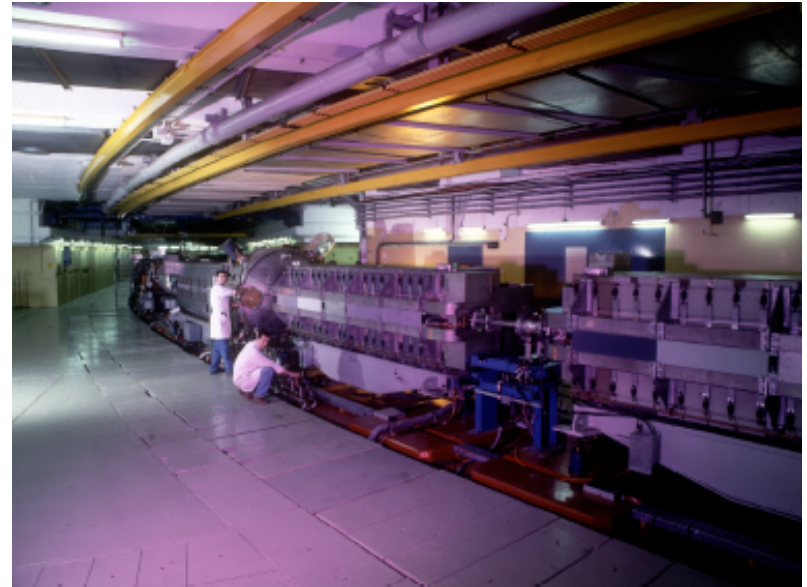

SPS (Super Proton Synchrotron) provides protons to

- **North Area**
 - beam tests for detector studies/calibration, material studies
 - **COMPASS** experiment (hadron spectroscopy)
 - NA62 experiment to study rare kaon decays, NA61, NA63
- **AWAKE** (accelerator R&D) & **CNGS** (neutrino beam to the Italy)

Difference Matter-Antimatter: the AD experiments

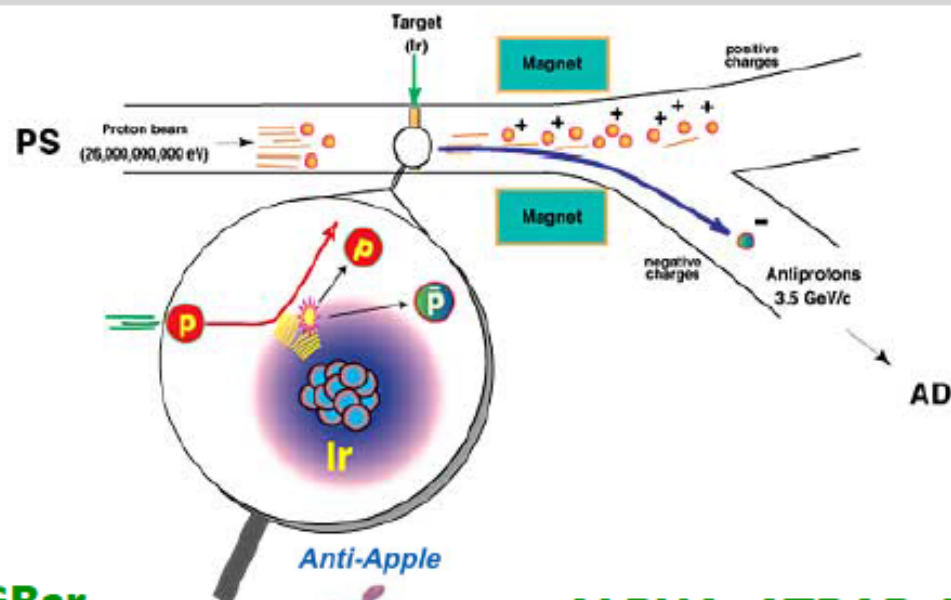

AEGIS and GBar experiments:

Comparing the behaviour of hydrogen and anti-hydrogen in the earth's **gravitational field**



ALPHA, ATRAP, ASACUSA experiments:

Looking for differences between hydrogen and anti-hydrogen using **spectroscopy** (well established technique, Gustav Robert Kirchhoff, Robert Wilhelm Bunsen 1859)



...and the **BASE** experiment is measuring the **magnetic moment of the anti-proton**



Decay	Branching Ratio ($\times 10^{10}$)	
	Theory (SM)	Experiment
$K^+ \rightarrow \pi^+ \nu \bar{\nu} (\gamma)$	$0.911 \pm 0.072^{[1]}$	$1.73_{-1.05}^{+1.15[2]}$

A. Ceccucci SPSC 14.4.15

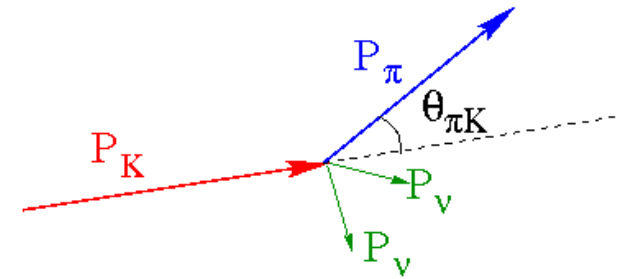

Gigatracker: K beam
 Calo: vetos
 Tracker: $p(\pi^+)$
 PID (RICH)

Goal: 10% measurement until LS2 (~1 event/day)
Note: br is about 10^{-10}

KOTO at JPARC to measure $K_L \rightarrow \pi^0 \nu \bar{\nu}$ (CP violating)
 BELLE II to measure V_{cb}, V_{ub}
 LHCb to provide new γ, cf
 [1] Buras et al 1503.02693

→ Global connections..

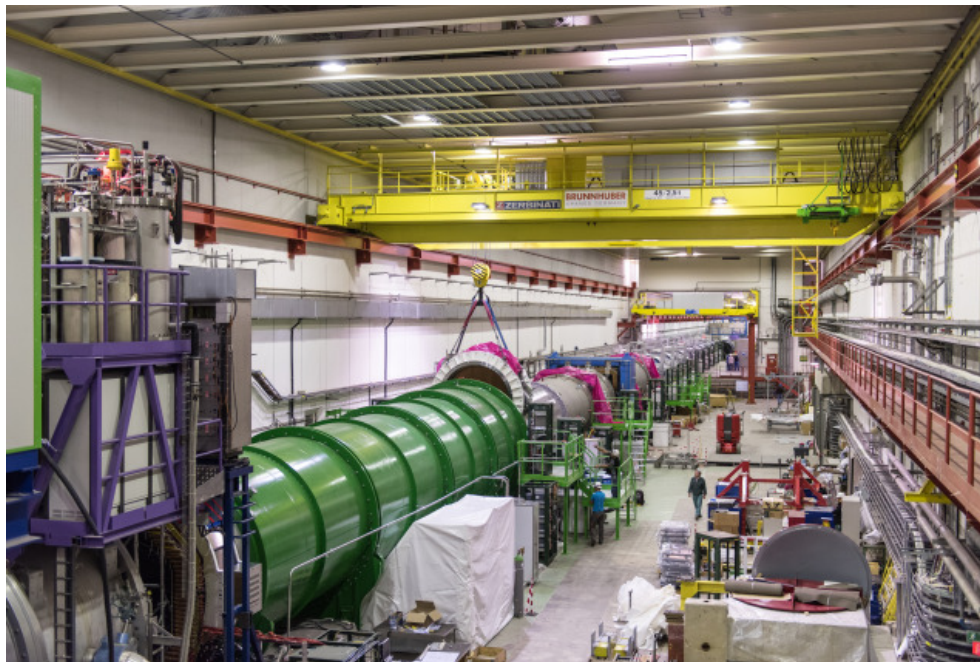

NA62 detector – will be complete in June this year.

COMPASS

Two-stage spectrometer

- large angular acceptance
- broad kinematical range
- ~250000 channels
- > 1000 TB/year

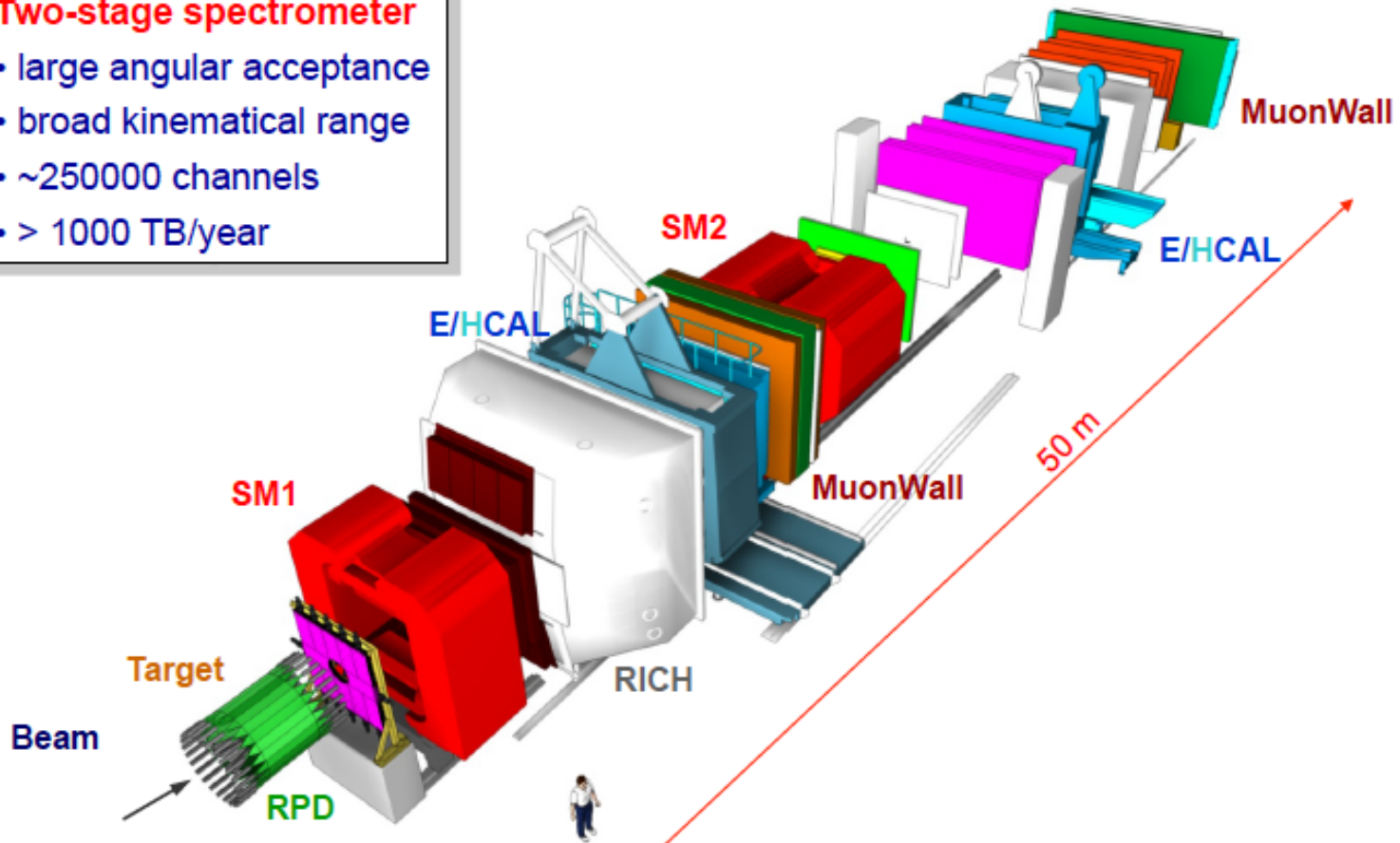

[COMPASS, P. Abbon et al., NIMA 577, 455 (2007)]

Approved for another year of Drell-Yan and 2 years DVCS data taking

Neutrino Platform at CERN

CERN broke symmetry and announced that it will freeze for the moment all types of Neutrino beams at CERN (Short and Long Baseline) in favor of common activities in US and Japan

S. Bertolucci at CERN, 3.3.15

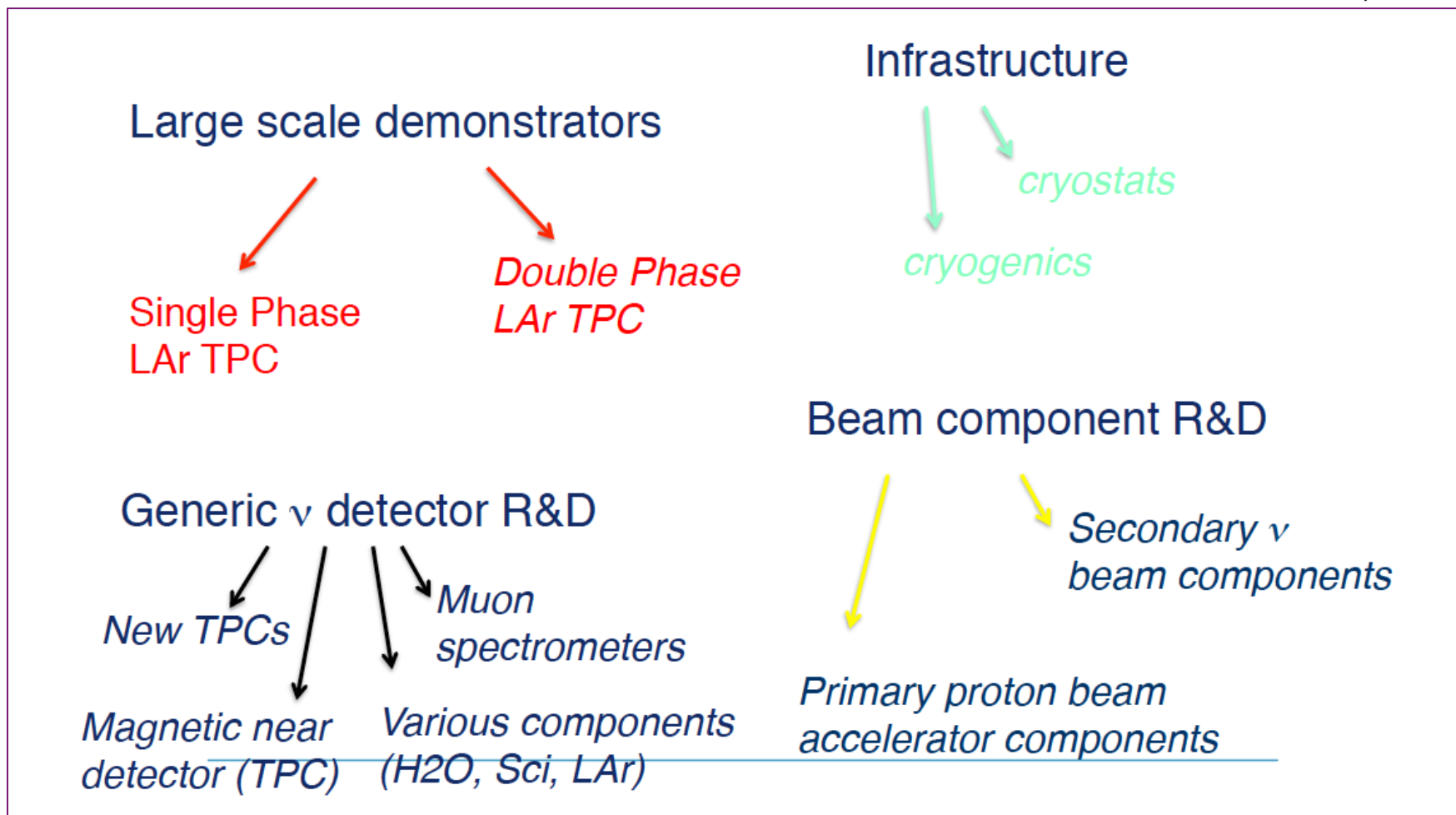

SHiP

(SEARCH FOR HIDDEN PARTICLES)

- ◆ General purpose fixed target facility at CERN
 - ◆ 400 GeV proton spills (4×10^{13} p.o.t.) from a dedicated beam line at the SPS accelerator

Primary physics goals

- ◆ Explore **Hidden portals and extension of the SM** incorporating *long-lived and very weakly interacting particles*
 - ◆ Sterile neutrinos (Heavy Neutral Leptons)
 - ◆ Dark photons
 - ◆ Paraphoton
 - ◆ SUSY: Sgoldstino, Light neutralino
- ◆ Study **ν_τ and anti- ν_τ interactions**
 - ◆ Perform cross section measurements
 - ◆ Estimate structure functions (F_4 and F_5) from charged current neutrino nucleon deep-inelastic scattering
- ◆ Study **nucleon strangeness content** with charm production from neutrino scattering

Neutrinos: $\beta\beta$ decay & β direct mass measurement

current generation next generation

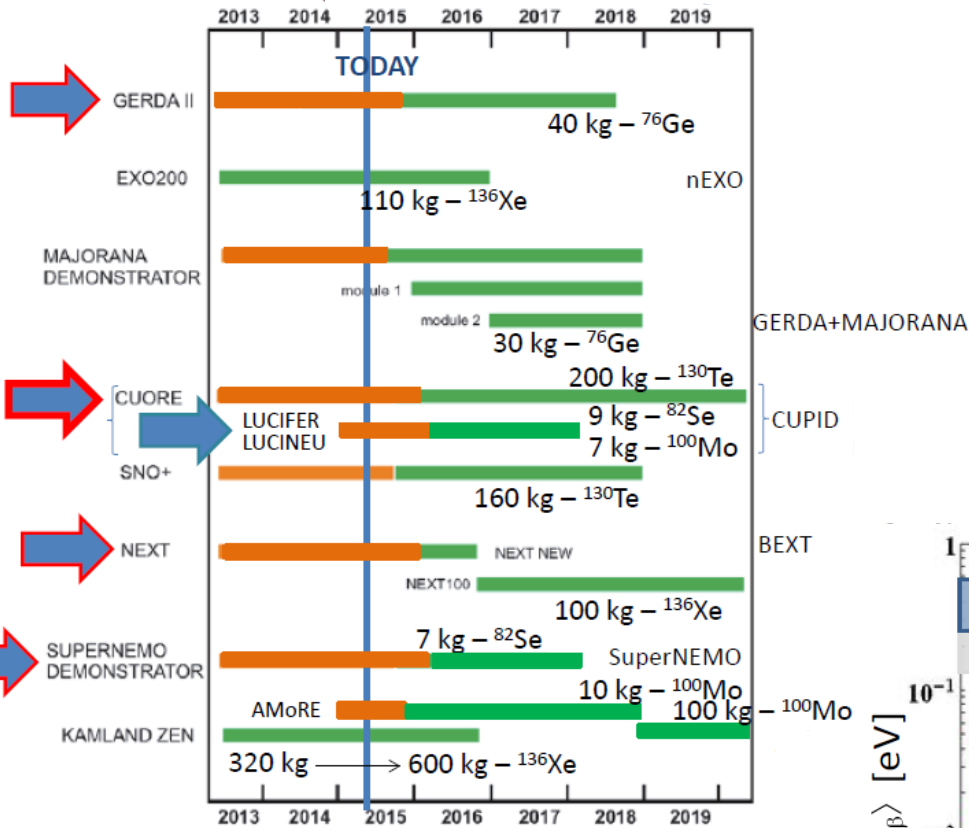

Direct mass measurement
Karlsruhe Tritium Neutrino Exp.
KATRIN: start data taking in 2016
 endpoint tritium β decay
 Sensitivity of 0.2 eV to $m(\nu_e)$

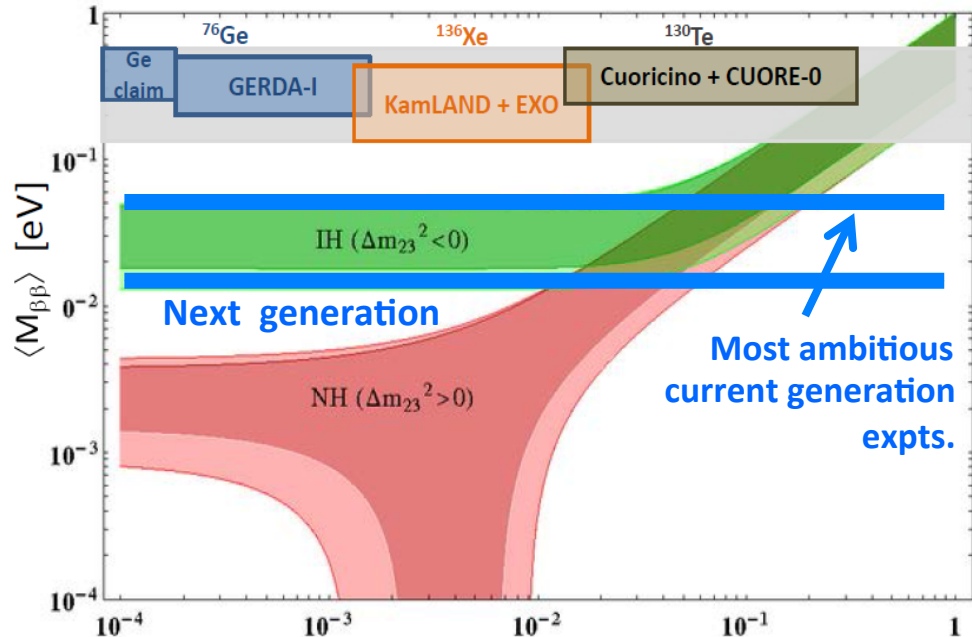
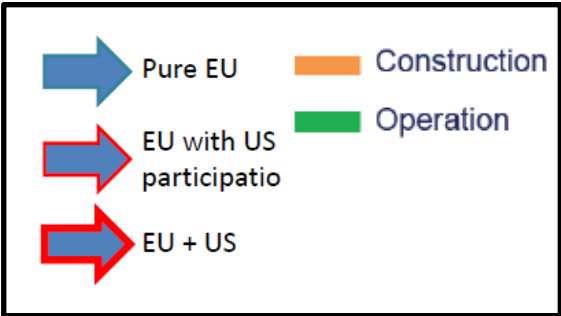

Non-collider Physics

Dark Matter

Astro-particle Physics

Fixed Target at CERN

Neutrinos

Upgrading the LHC

Luminosity

Electrons

The Big Machines

ILC, CLIC, CepC, FCC-ee

FCC [hh-he]

LHC Schedule until LS3

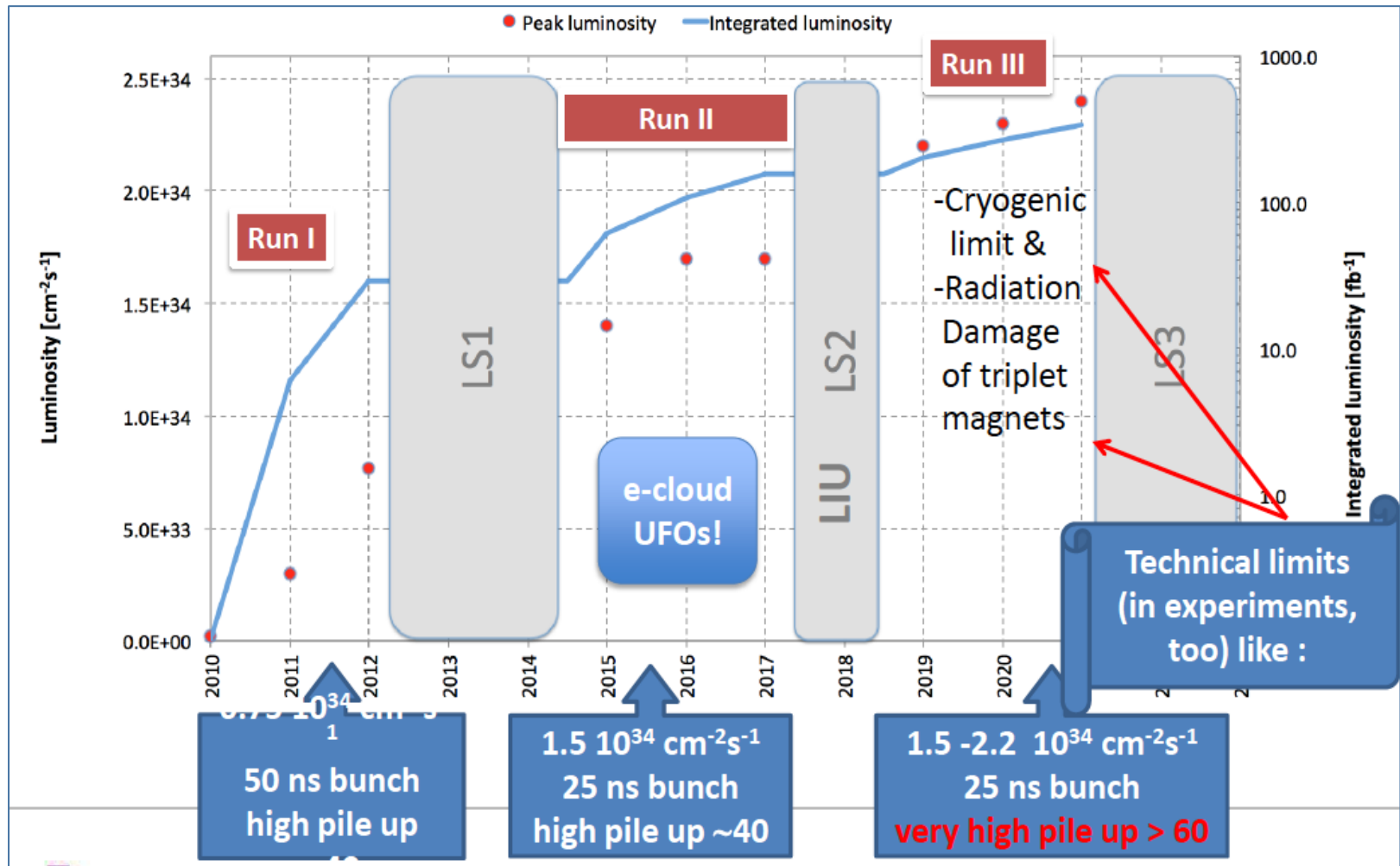

Run 1 was impressive. LS1 was successful thanks to 1000 or so people!
 The success and operation of the LHC is of prime importance for all.
 The results of the high energy run (100fb^{-1} until 2018) may change HEP

Current Long Term Planning of the LHC Operation

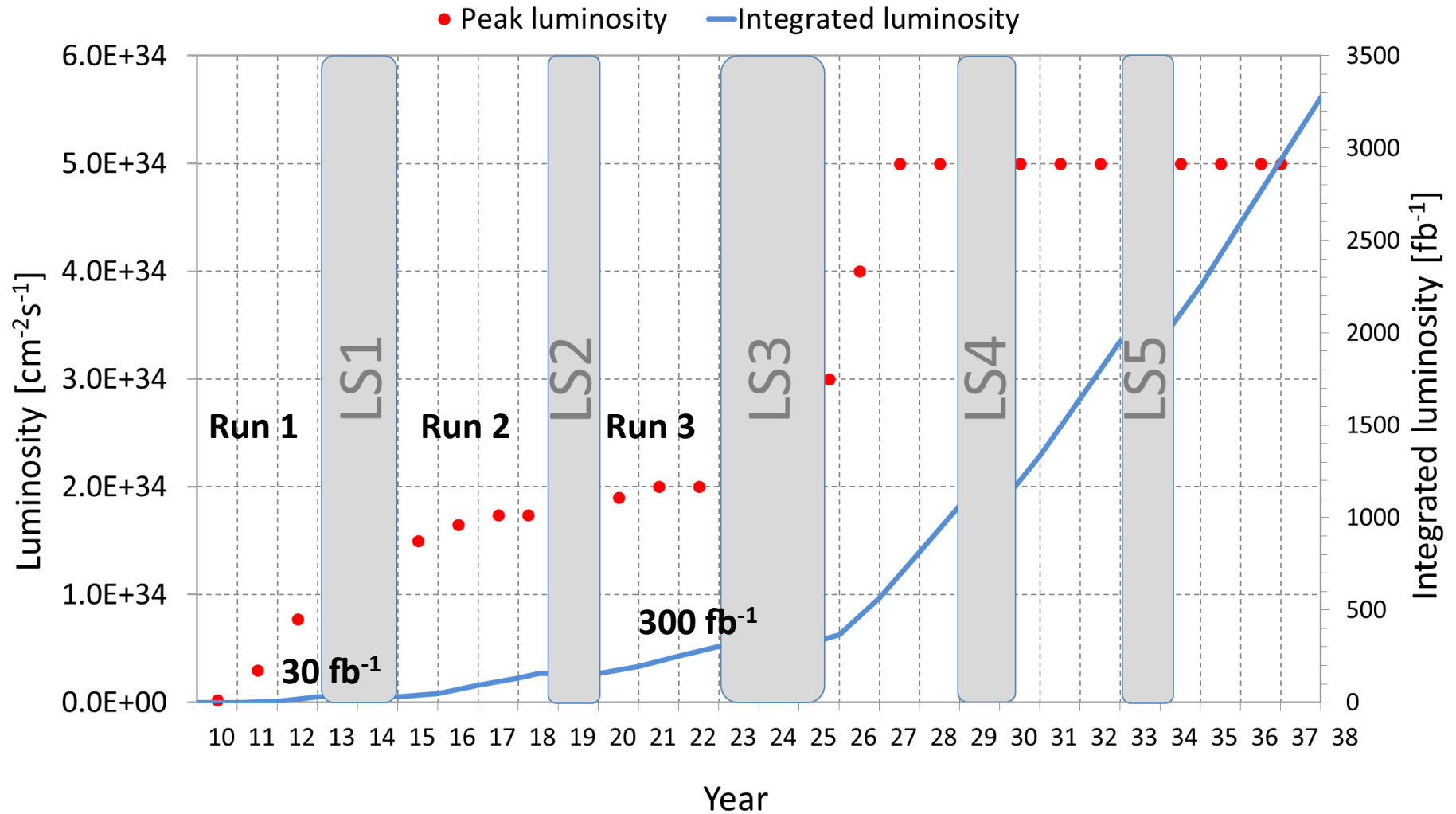

F. Bordry at the FCC Workshop at Washington DC March 2015

Luminosity Upgrade – SUSY?

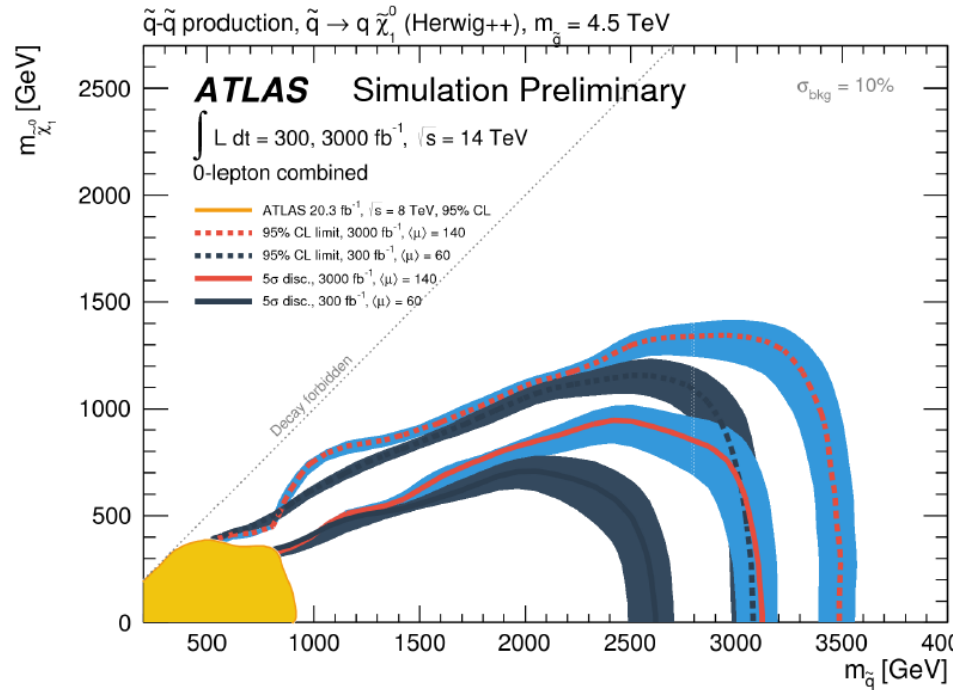

5 σ up to $\sim 2.5 \text{ TeV}$ gluinos
@ HL-LHC

5 σ up to $\sim 3 \text{ TeV}$ squarks
5 σ up to $\sim 1.2 \text{ TeV}$ stops
5 σ up to $\sim 1.3 \text{ TeV}$ sbottoms
@ HL-LHC

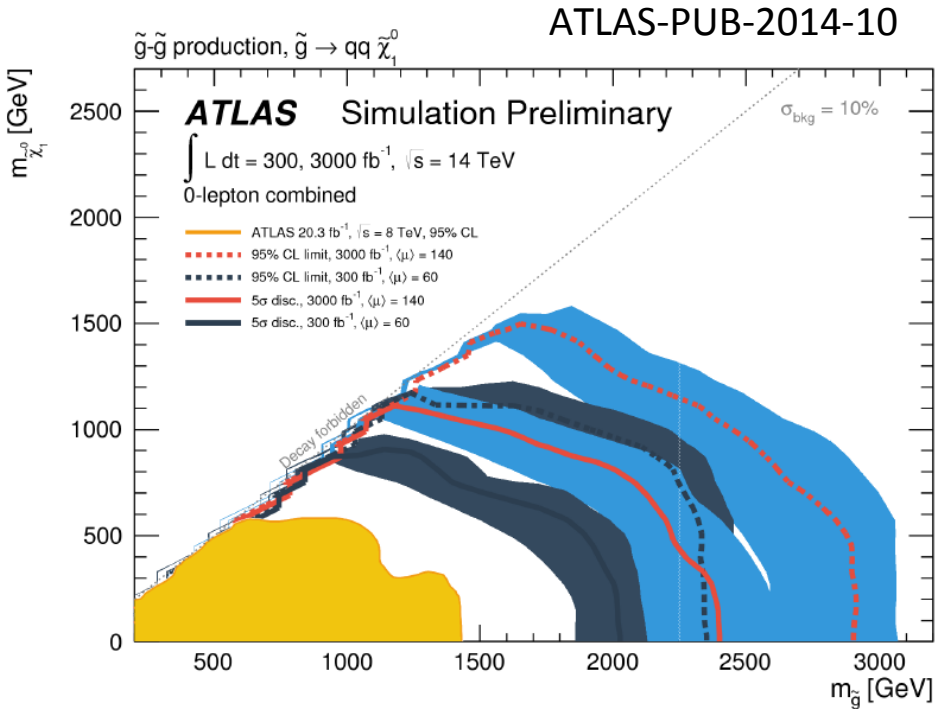

cf Flera Rizatdinova at this workshop

Note that RUN 2 is for 100 fb^{-1} until LS2. Searches need **energy**, clarity and luminosity

Issues for the Future (Starting now!)

1. What is the agent of EWSB? *There is a Higgs* Might there be several?
2. Is the Higgs boson elementary or composite? Does it interact with itself? What triggers EWSB?
3. Does the Higgs boson give mass to fermions only to the weak bosons? What sets the masses: mixings of the quarks and leptons? *(How) is fermion mass related to the electroweak scale?*
4. Are there new flavor symmetries that give in into fermion masses and mixings?
5. What stabilizes the Higgs-boson mass below 125 GeV?
6. Do the different CC behaviors of LH, RH fermions reflect a fundamental asymmetry in nature's laws?
7. What will be the next symmetry we recognize? Are there additional heavy gauge bosons? Is nature supersymmetric? Is EW theory contained in a GUT?
8. Are all flavor-changing interactions governed by the standard-model Yukawa couplings? Does "minimal flavor violation" hold? If so, why?
9. Are there additional sequential quark & lepton generations? Or new exotic (vector-like) fermions?
10. What resolves the strong CP problem?
11. What are the dark matters? Any flavor structure?
12. Is EWSB an emergent phenomenon connected with strong dynamics? How would that alter our conception of unified theories of the strong, weak, and electromagnetic interactions?
13. Is EWSB related to gravity through extra spacetime dimensions?
14. What resolves the vacuum energy problem?
15. (When we understand the origin of EWSB) What lessons does EWSB hold for unified theories of inflation? ... for dark energy?
16. What explains the baryon asymmetry of the universe? Are there new (CC) CP-violating phases?
17. Are there new flavor-preserving phases? What would observation, or more stringent limits, on electric-dipole moments imply for BSM theories?
18. (How) are quark-flavor dynamics and lepton-flavor dynamics related (beyond the gauge interactions)?
19. At what scale are the neutrino masses set? Do they speak to the TeV scale, unification scale, Planck scale, ...?
20. How are we prisoners of conventional thinking?

LHC Luminosity Upgrade - Accelerator

- Technical bottle necks (e.g. cryogenics) → New addit. Equipment
- Insertion magnet lifetime and aperture:
 - New insertion magnets and low- β with increased aperture
- Geometric Reduction Factor: → SC Crab Cavities
 - New technology and a first for a hadron storage ring!
- Performance Optimization: Pileup density → luminosity levelling
 - devise parameters for virtual luminosity \gg target luminosity
- Beam power & losses → additional DS (cold region) collimators
- Machine efficiency and availability:
 - # R2E → removal of all electronics from tunnel region
 - # e-cloud → beam scrubbing (conditioning of surface)
 - # UFOs → beam scrubbing (conditioning of surface)



LHC Luminosity Upgrade - Detectors

HL-LHC Need radiation hardness of current n-in-n pixel sensors at fraction of the cost

→ **n-in-p technology**

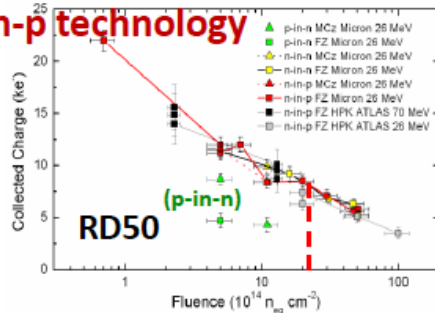

Many large area prototypes produced

10cm×10cm
4×1280 strip
n-in-p sensor

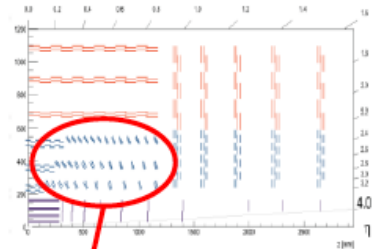

12 module ATLAS prototype stave: 61440 channels ~600e noise

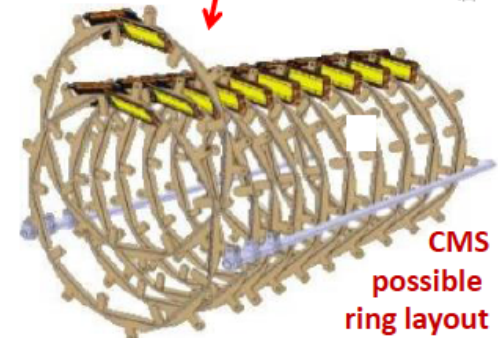
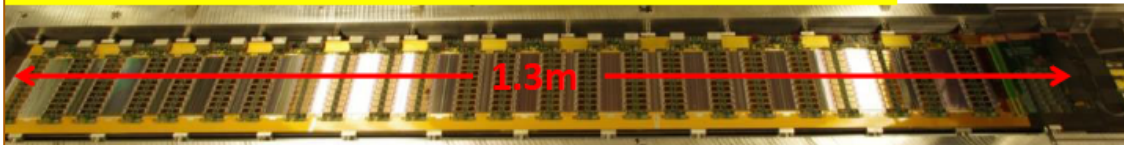

CMS possible ring layout



4 row wire bonds

Powering (DC/DC or Serial), HV multiplexing, CO₂ embedded cooling, low mass modular supports & services

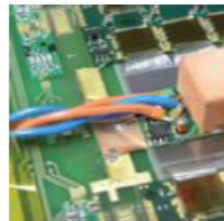

Module with on-board DC-DC converter

STV10 DC-DC on module

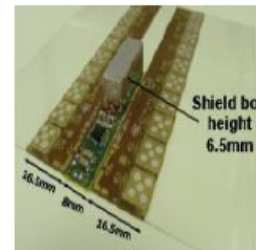

Thermo-Mechanical Module with compact DCDC converter

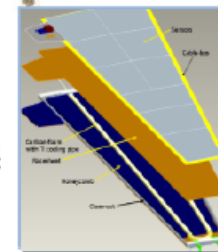

ATLAS Wedges and Discs



Frank Hartmann,
Daniel Muenstermann

Huge effort for LHC detector upgrades, LS2 and LS3 – dominates till 2023 all we do
of P.Allport and D.Contardo report to ECFA 12/2014, also ECFA Report 15/2015 Summary of HL LHC Workshops

LHC Electron Beam Upgrade

LHeC

- Finest microscope of the world
- The next machine which sees H
- Transforms LHC in precision lab.
- PDFs gain $O(.5)$ TeV search range
- Revolution of nuclear structure

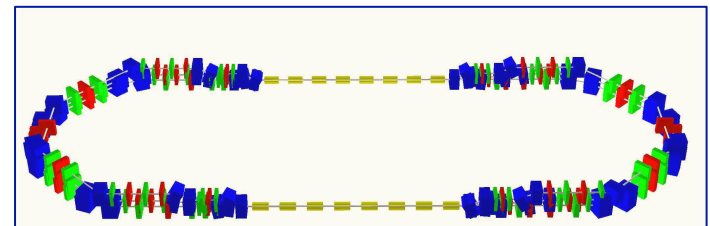

ERL Facility:

Two LINACS 150 MeV, 3 passes with energy recovery \rightarrow 900MeV

Design Concept 2015

AsTEC, BINP, CERN, Jlab + scRF, ERL, Physics, Tests

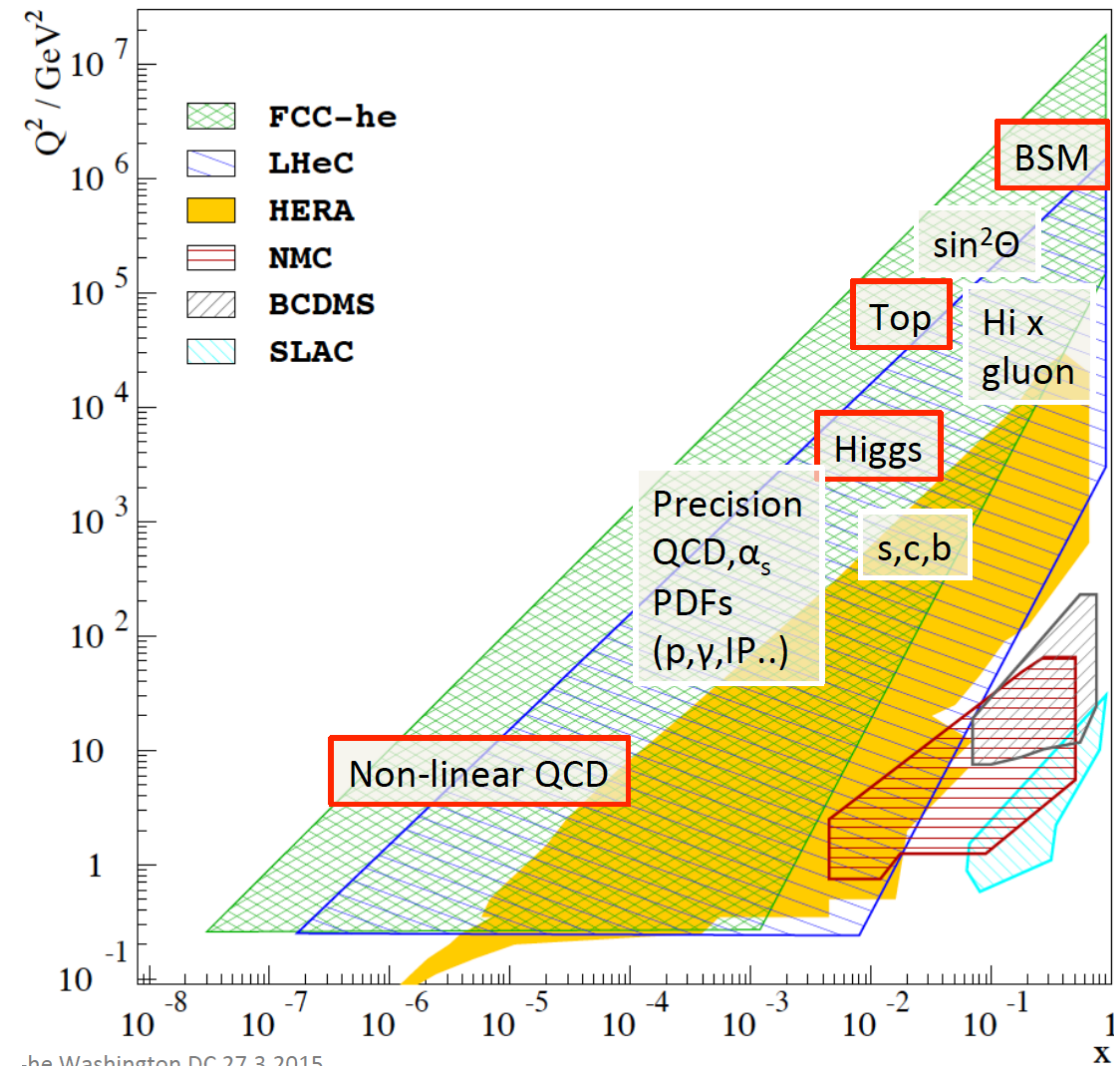

**Luminosity of order $10^{34} \text{cm}^{-2} \text{s}^{-1}$
in concurrent ep-pp operation**

Civil Engineering Footprint

LHeC construction planning	YEAR 1	YEAR 2	YEAR 3	YEAR 4	YEAR 5	YEAR 6	YEAR 7
Land negotiations	Red	Red					
Environmental Impact Study		Green	Green				
Building permits			Blue				
Detailed design & tendering		Orange	Yellow				
Construction				Brown	Brown	Brown	Brown

7 years for 9km
Civil Engineering

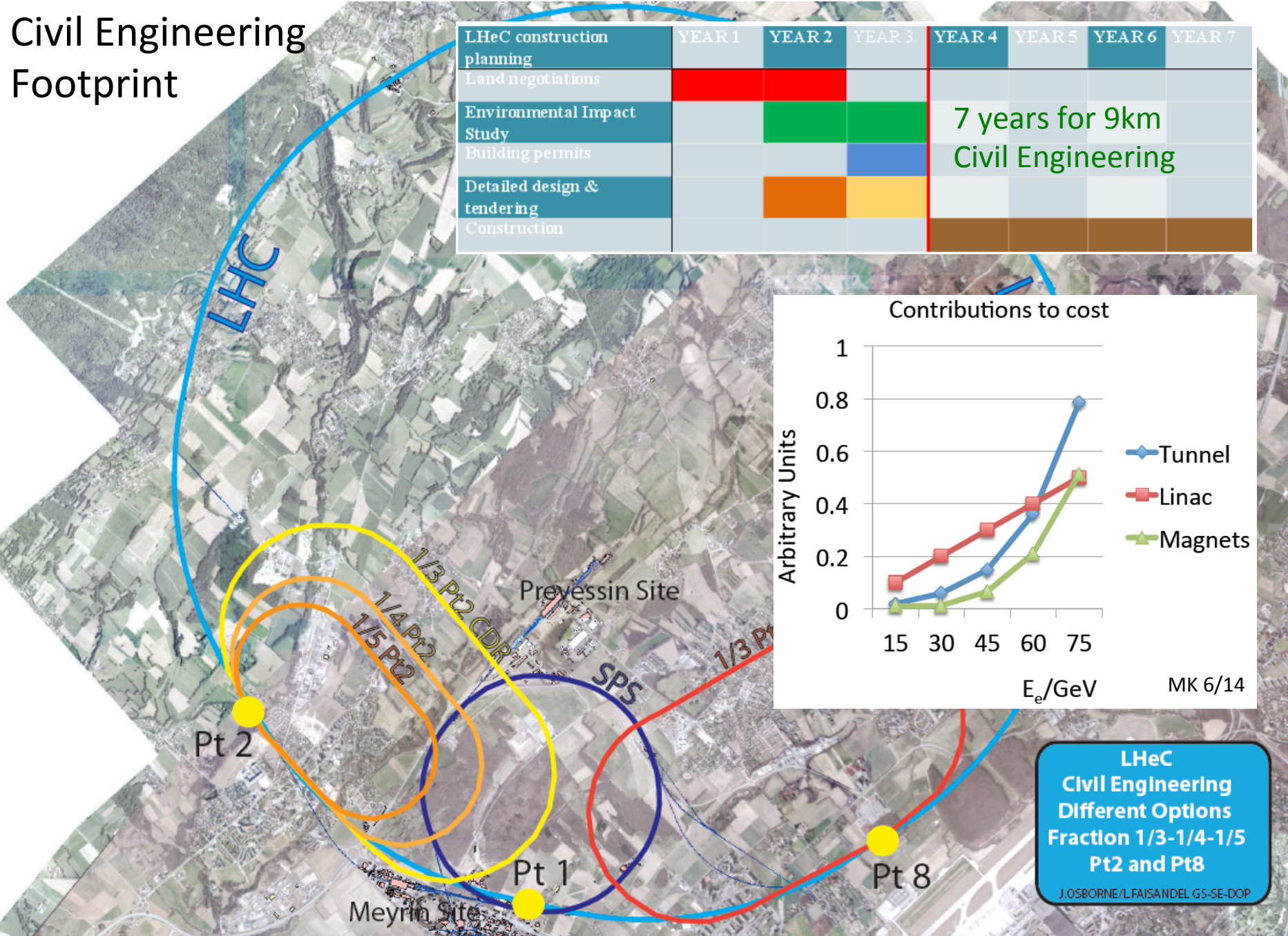
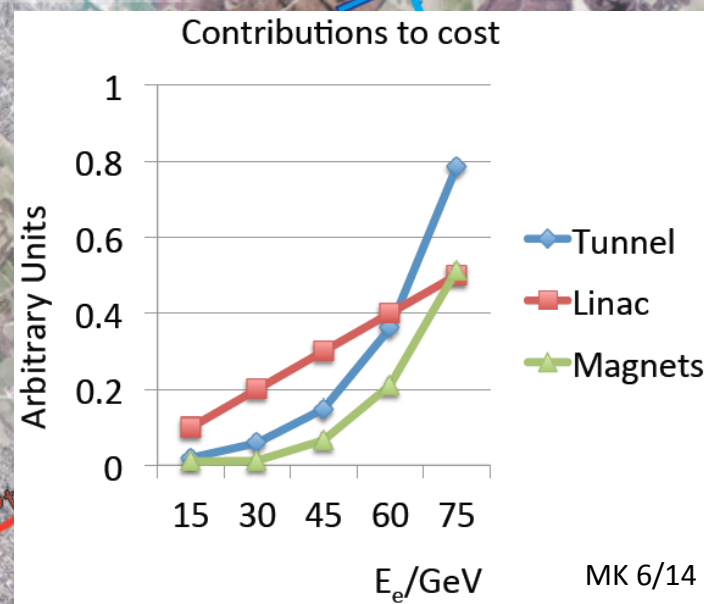

LHeC
Civil Engineering
Different Options
Fraction 1/3-1/4-1/5
Pt2 and Pt8
J.OSBORNE/L.FAISANDEL.GS-SE-DOP

Luminosity Upgrade - Higgs

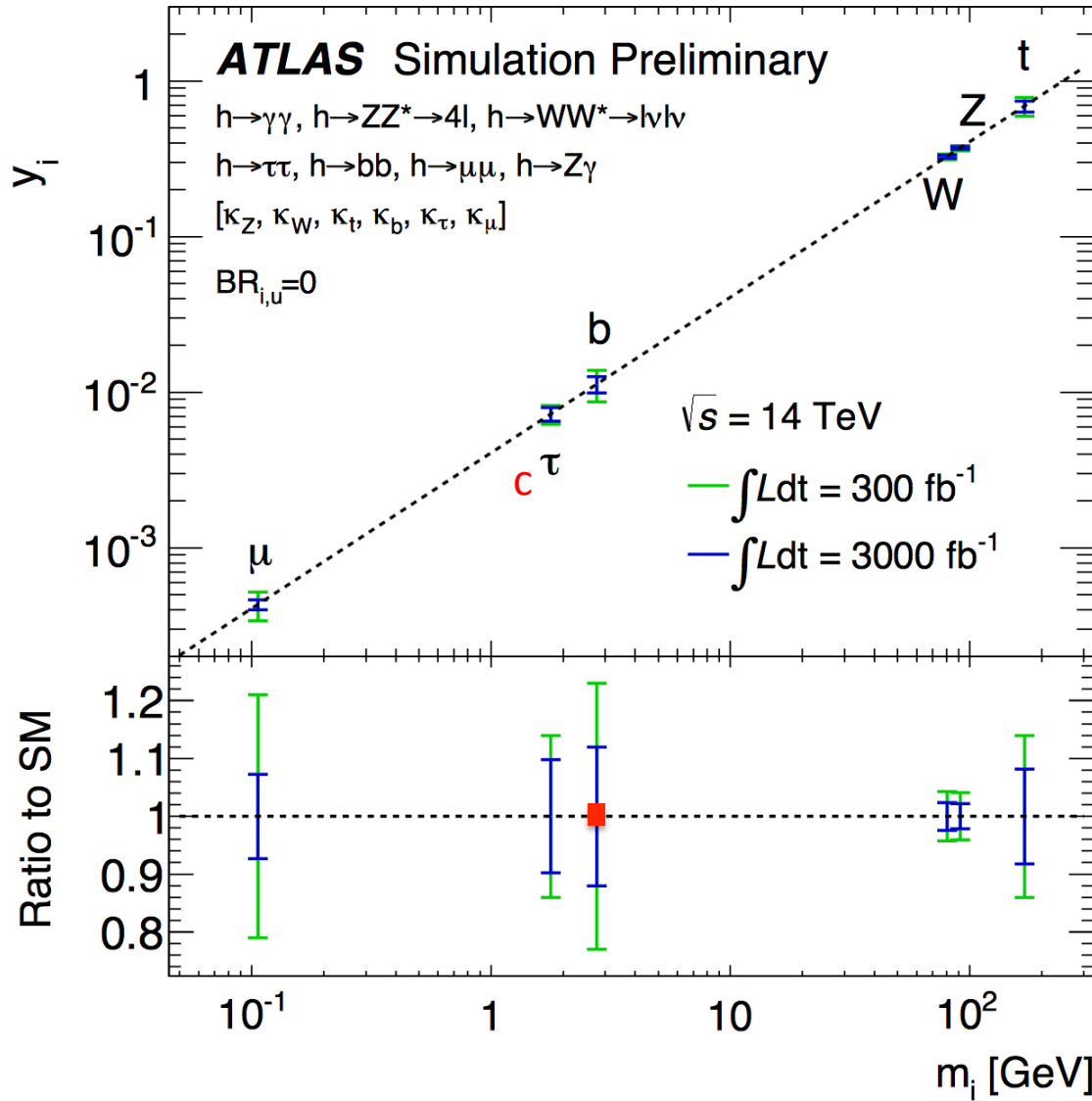

LHeC, 1 ab^{-1}
 Work in progress
 Br: b 59% c 3%

$$y_{V,i} = \sqrt{\kappa_{V,i} \frac{g_{V,i}}{2v}} = \sqrt{\kappa_{V,i}} \frac{m_{V,i}}{v} \quad y_{F,i} = \kappa_{F,i} \frac{g_{F,i}}{\sqrt{2}} = \kappa_{F,i} \frac{m_{F,i}}{v}$$

Non-collider Physics

Dark Matter

Astro-particle Physics

Fixed Target at CERN

Neutrinos

Upgrading the LHC

Luminosity

Electrons

The Big Machines

ILC, CLIC, CepC, FCC-ee

FCC [hh-he]

Predicting is difficult, especially when it concerns the future (Victor Weisskopf)

ILC

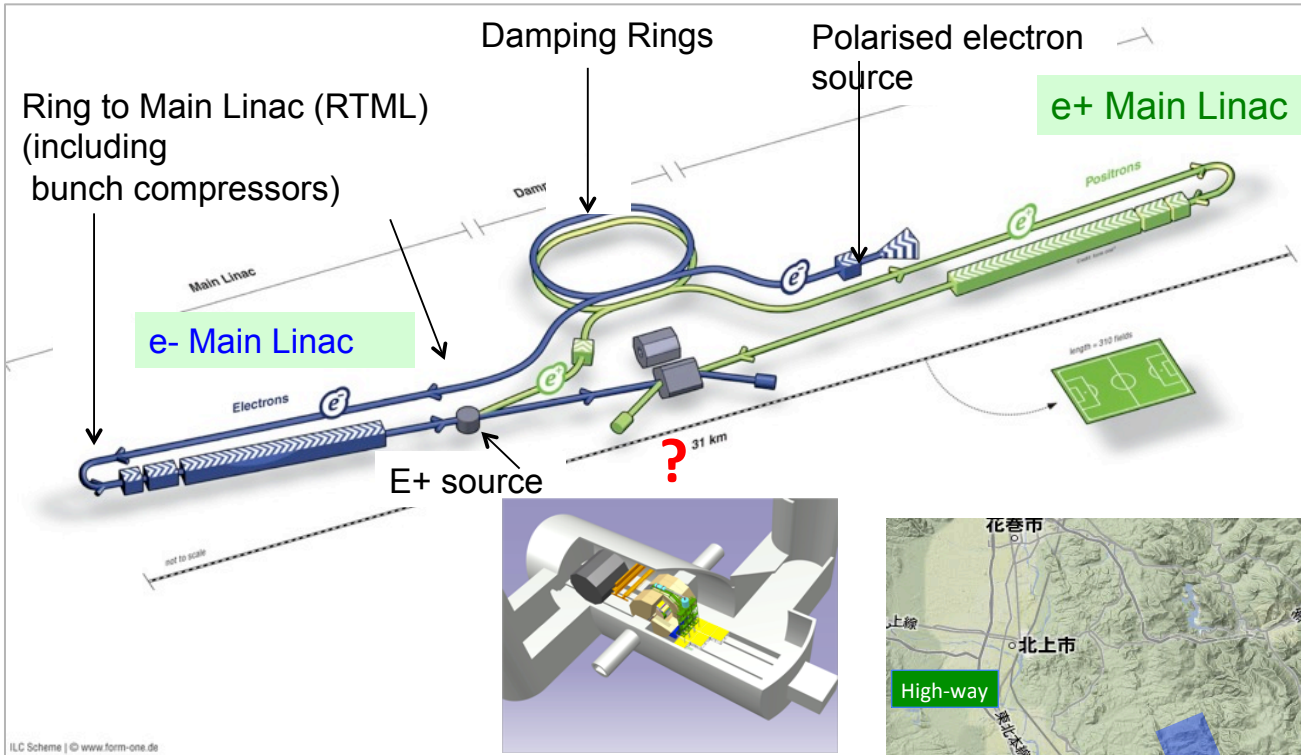

Formerly
TESLA+XFEL in D
NLC in US
... ILC ...
ILC in Japan
much progressed,
a major enterprise
for 2+3 decades

250-500-.. GeV in cms. $L=O(10^{34}) \text{ cm}^{-2} \text{ s}^{-1}$

Europe may be engaged in cryo-module production and delivery to Japan, besides further participation

Push-pull or two-in-one Collaborations?

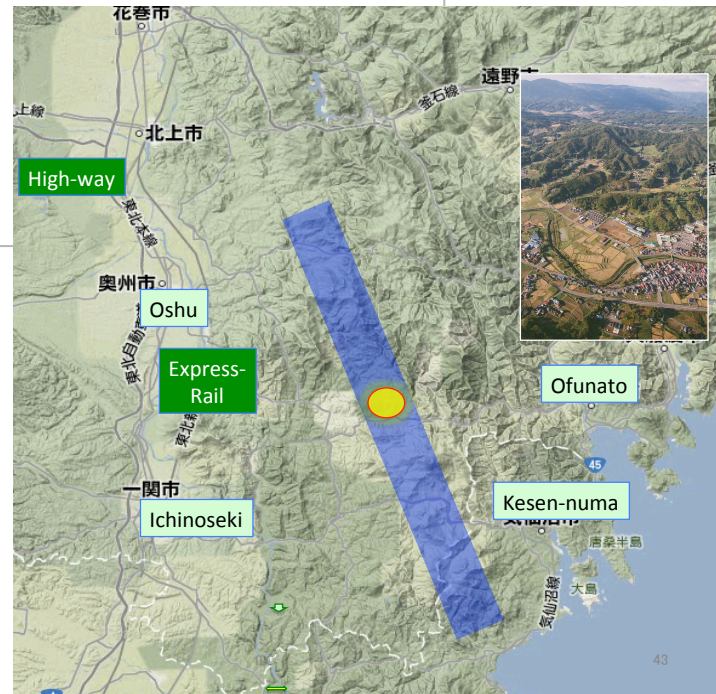

ILC duration of construction after t_0

Years	TDR baseline Scenario
1 - 2	Pre-preparation for 2yrs (for technical effort continuity)
3 - 6	Preparation (4 yrs)
7 - 15	Construction (9 yrs)
(12 -)	(start installation)
(13 -)	(start preparation for Operation)
16 -	Beam Commissioning start
17 -	Operation at 250 ~ 500 GeV (550 GeV)
TBD	Toward 500 GeV HL upgrade
TBD	Toward 1 TeV upgrade

This means ~25 years from t_0 to $1ab^{-1}$

From S.Stapness, Epiphany Cracow 1/15

Higgs in e^+e^-

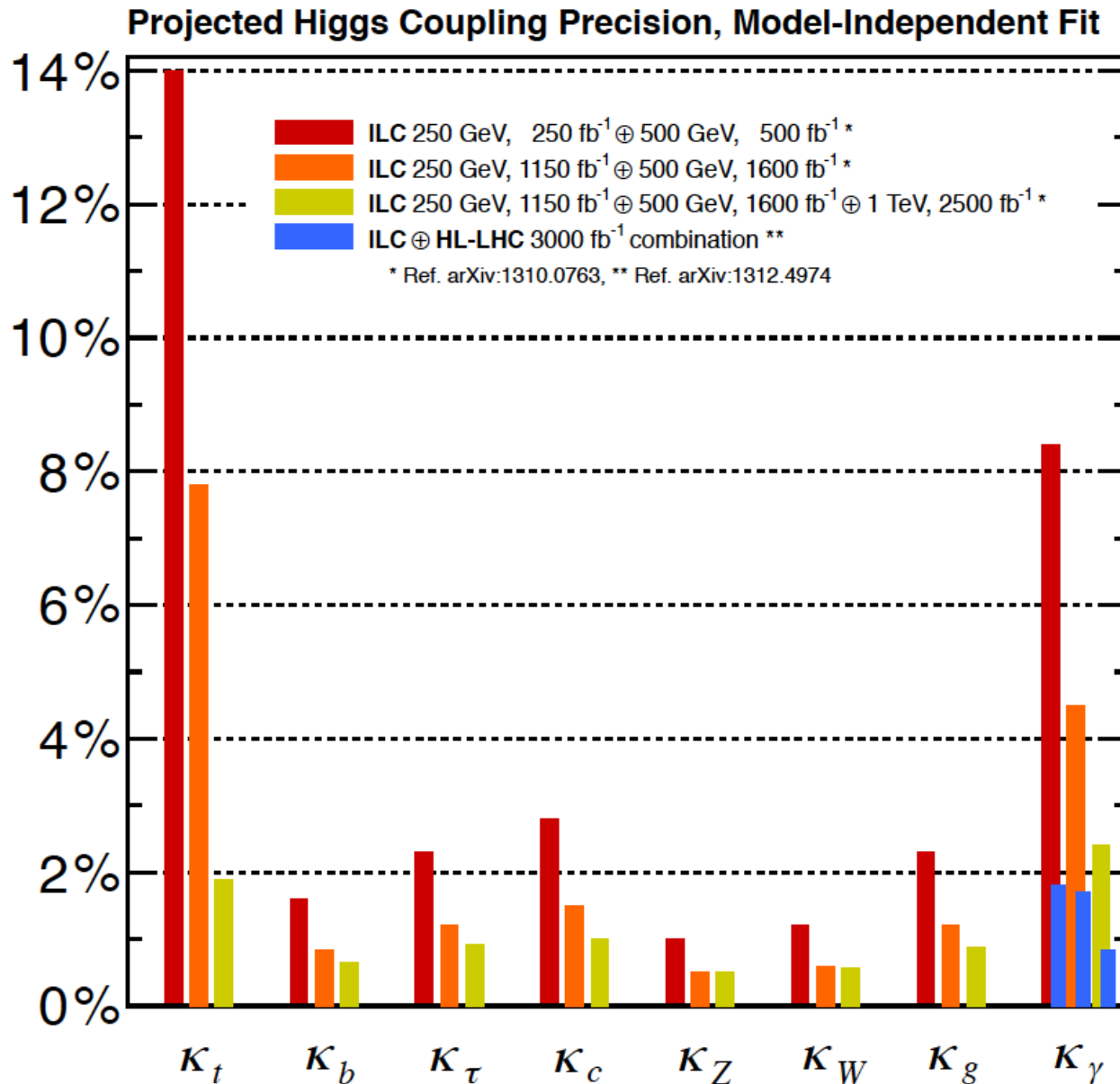

Note the huge
Luminosities

Yellow

1ab⁻¹ at 250 GeV

1.6 ab⁻¹ at 500

2.5 ab⁻¹ at 1 TeV

→ 5ab⁻¹ in three
machine stages!

ILC as an example

July 23, 2014, White House, Eisenhower Executive Office Building



Visit of Japanese Diet member+ science delegation this week (April 2015) to DC

S.Yamashita, 21.4.15 Status of ILC

ILC Statements

e) There is a strong scientific case for an electron-positron collider, complementary to the LHC, that can study the properties of the Higgs boson and other particles with unprecedented precision and whose energy can be upgraded. **The Technical Design Report of the International Linear Collider (ILC) has been completed**, with large European participation. The initiative from the Japanese particle physics community to host the ILC in Japan is most welcome, and European groups are eager to participate. ***Europe looks forward to a proposal from Japan to discuss a possible participation.***

European Strategy Statement from 2013

Just waiting for positive sign from the Japanese government is not a recommended strategy, since Japanese government is waiting for the sign of ILC supports from the other countries/regions.

Sachio Komamiya, 21.4.2015 Chair of the Linear Collider Board

CLIC

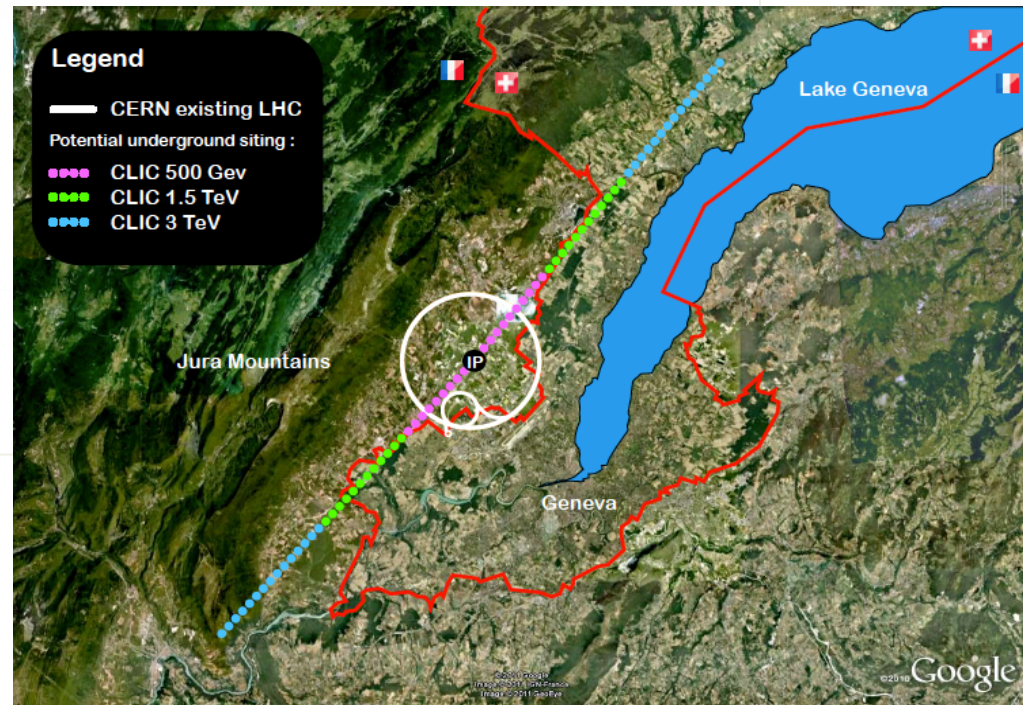
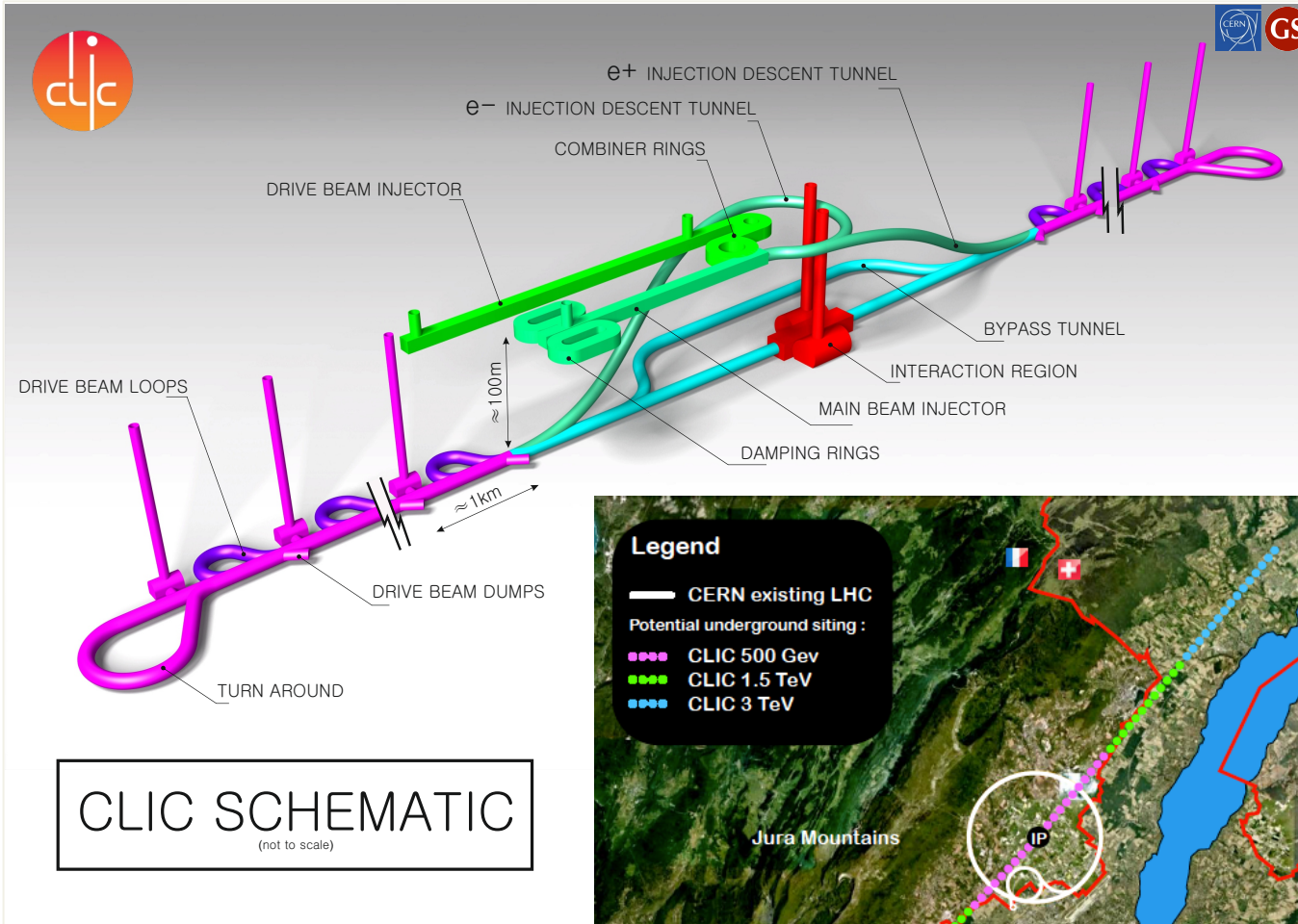

CLIC Future Plans

2013-18 Development Phase

Develop a Project Plan for a staged implementation in agreement with LHC findings; further technical developments with industry, performance studies for accelerator parts and systems, as well as for detectors.

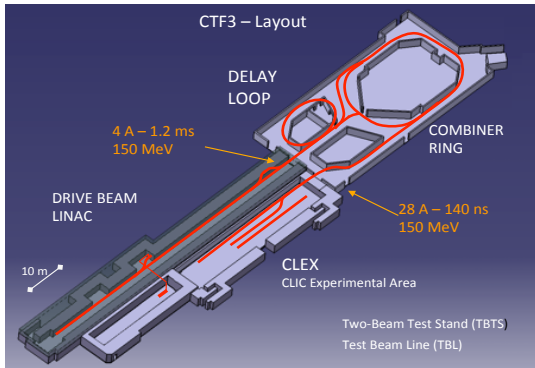

2018-19 Decisions

On the basis of LHC data and Project Plans (for CLIC and other potential projects as FCC), take decisions about next project(s) at the Energy Frontier.

4-5 year Preparation Phase

Finalise implementation parameters, Drive Beam Facility and other system verifications, site authorisation and preparation for industrial procurement.

Prepare detailed Technical Proposals for the detector-systems.

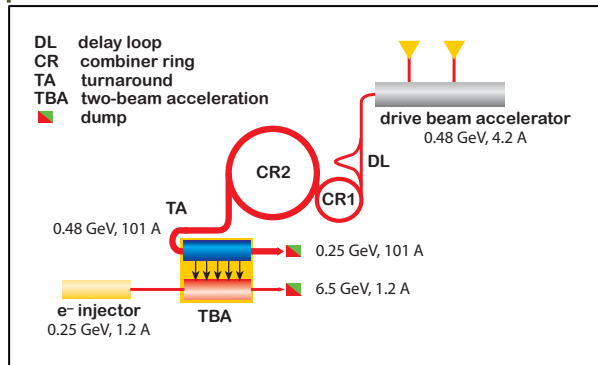

2024-25 Construction Start

Ready for full construction and main tunnel excavation.

Construction Phase

Stage 1 construction of CLIC, in parallel with detector construction.

Preparation for implementation of further stages.

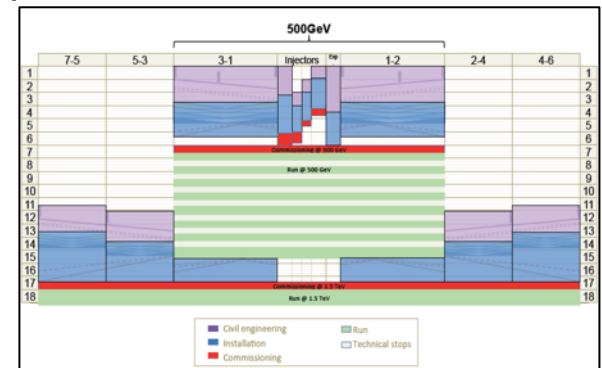

Commissioning

Becoming ready for data-taking as the LHC programme reaches completion.

ILC and CLIC parameters

Parameter	Symbol [unit]	ILC	CLIC
Centre of mass energy	E_{cm} [GeV]	500	3000
luminosity	L [$10^{34}\text{cm}^{-2}\text{s}^{-1}$]	1.8	6
Luminosity in peak	$L_{0.01}$ [$10^{34}\text{cm}^{-2}\text{s}^{-1}$]	1	2
Gradient	G [MV/m]	31.5	100
Particles per bunch	N [10^9]	20	3.72
Bunch length	σ_z [μm]	300	44
Collision beam size	$\sigma_{x,y}$ [nm/nm]	474/5.9	40/1
Vertical emittance	$\epsilon_{x,y}$ [nm]	35	20
Bunches per pulse	n_b	1312	312
Distance between bunches	Δz [mm]	554	0.5
Repetition rate	f_r [Hz]	5	50

ILC may be upgraded to larger energy and CLIC downgraded to lower..



Robert Jungk (1966)

Die grosse Maschine
-auf dem Weg in eine andere Welt

The big machine
-on the road into a new world

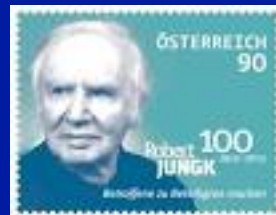

Theory to pave new ways

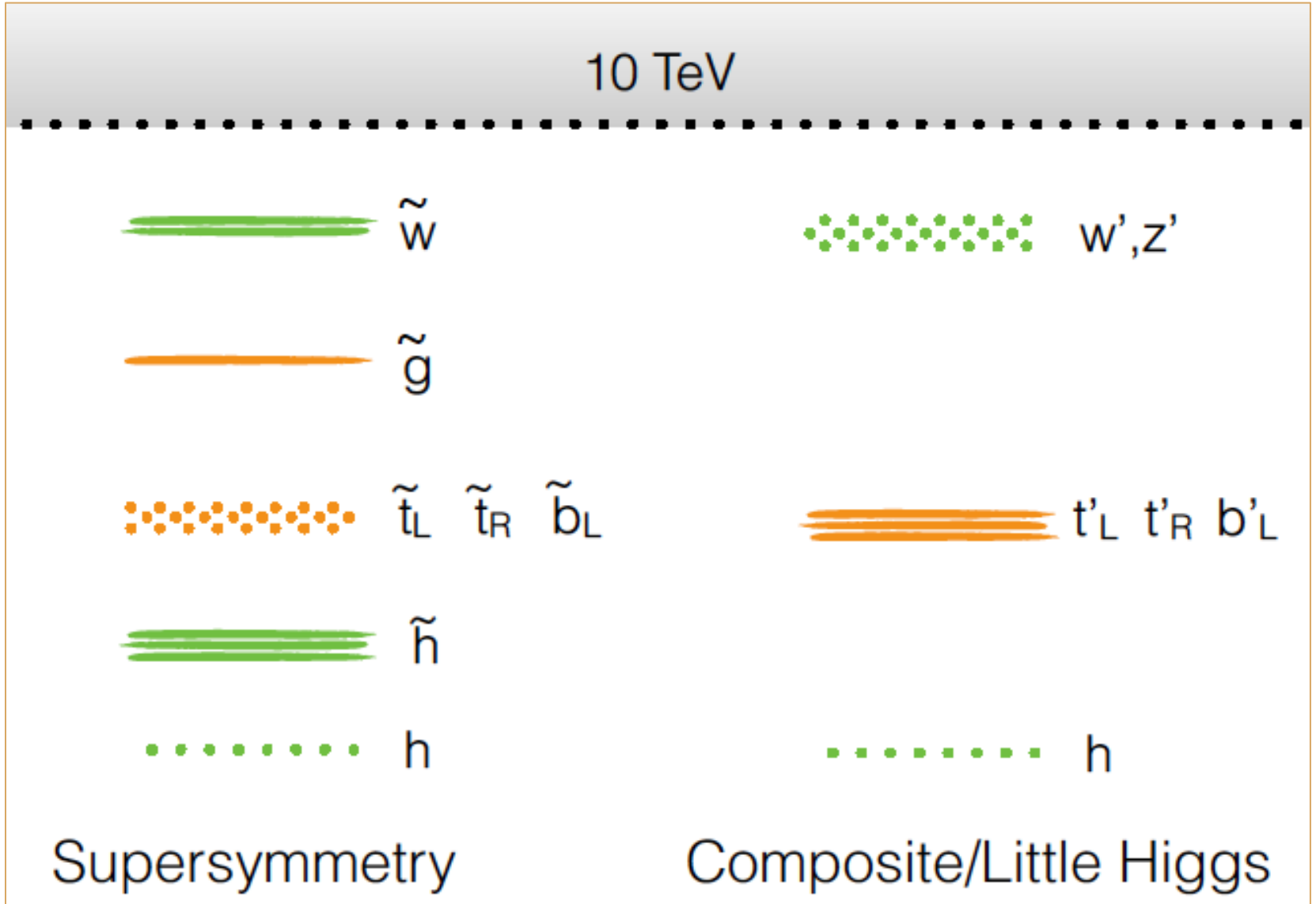

FCC Mandate

Scope

The main emphasis of the conceptual design study shall be the long-term goal of a hadron collider with a centre-of-mass energy of the order of 100 TeV (currently referred to as VHE-LHC) in a new tunnel of 80-100 km circumference for the purposes of studying physics at the highest energies. The hadron collider and its detectors shall determine the basic requirements for the tunnel, surface and technical infrastructures. The corresponding hadron injector chain shall be included in the study, taking into account the existing CERN accelerator infrastructure and long-term accelerator operation plans. The performance and cost of the hadron collider shall be compared to a high-energy LHC based on the same high-field magnet technology and housed in the LHC tunnel.

European strategy 2013 emphasized LHC exploitation, Higgs exploration, neutrinos and “design studies for accelerator projects in a global context with emphasis on pp and ee.”

FCC

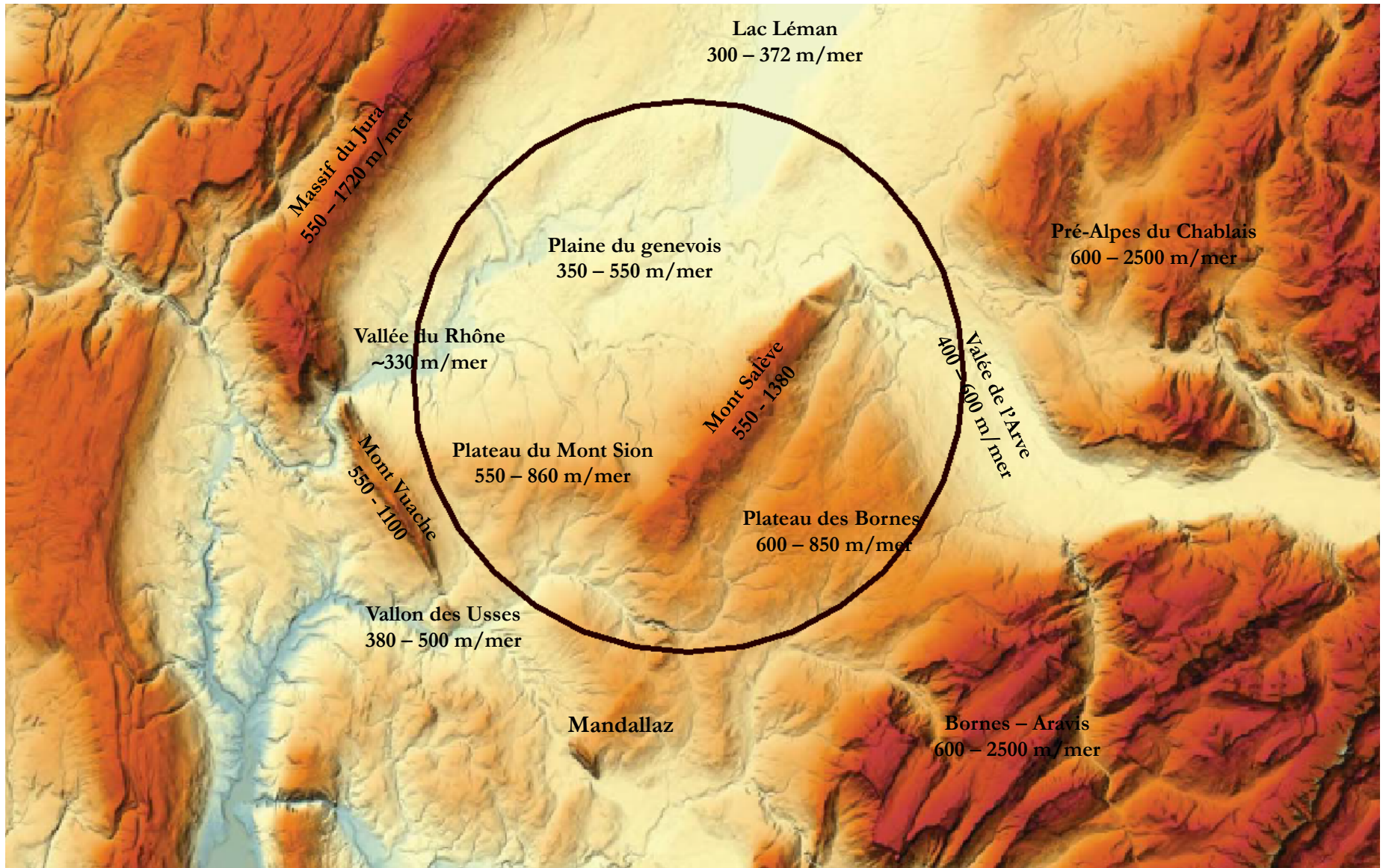

FCC - pp

	Baseline	Ultimate
Luminosity [$10^{34}\text{cm}^{-2}\text{s}^{-1}$]	5	20
Bunch distance [ns]	25 (5)	
Background events/bx	170 (34)	680 (136)
Bunch charge [10^{11}]	1 (0.2)	
Norm. emitt. [μm]	2.2(0.44)	
RMS bunch length [cm]	8	
IP beta-function [m]	1.1	0.3
IP beam size [μm]	6.8 (3)	3.5 (1.6)
Max ξ for 2 IPs	0.01 (0.02)	0.03
Crossing angle [σ']	12	Crab. Cav.
Turn-around time [h]	5	4

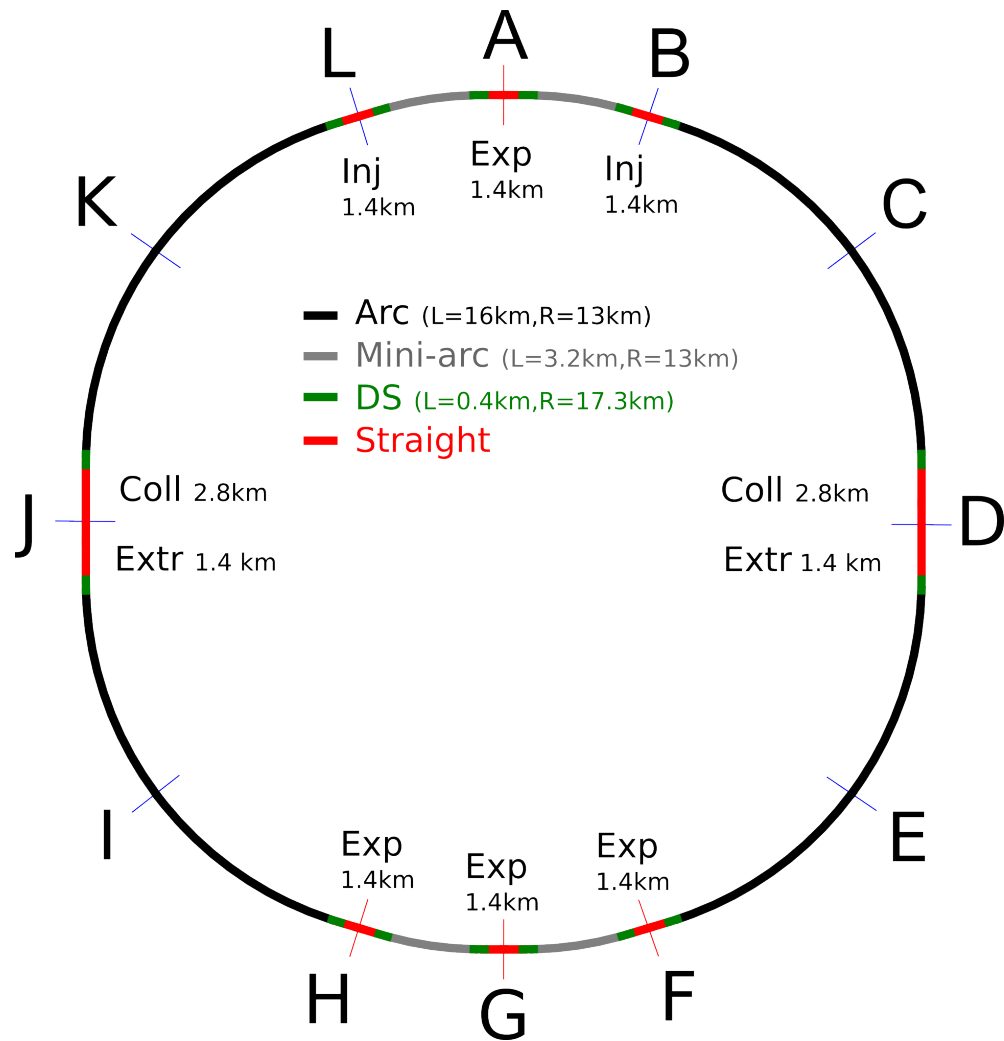

D.Schulte at FCC Workshop DC March 2015

Future SUSY

Assuming a massless LSP

Model	Limit [TeV]	Discovery Reach [TeV]	
	8 TeV 20 fb ⁻¹	14 TeV 3000 fb ⁻¹	100 TeV 3000 fb ⁻¹
$pp \rightarrow \widetilde{g}\widetilde{g} \rightarrow q\bar{q}\widetilde{\chi}_1^0 q\bar{q}\widetilde{\chi}_1^0$	1.4 (ATLAS)	2.3	11
$pp \rightarrow \widetilde{g}\widetilde{g} \rightarrow t\bar{t}\widetilde{\chi}_1^0 t\bar{t}\widetilde{\chi}_1^0$	1.4 (ATLAS)	2.0	6.0
$pp \rightarrow \widetilde{q}\widetilde{q}^* \rightarrow q\widetilde{\chi}_1^0 \bar{q}\widetilde{\chi}_1^0$	1.0 (CMS)	1.0	7.8
$pp \rightarrow \widetilde{t}\widetilde{t}^* \rightarrow t\widetilde{\chi}_1^0 \bar{t}\widetilde{\chi}_1^0$	0.7 (CMS)	1.2 ^a	6.5

^a[ATLAS projection](#)

M. Hance Aspen 15

SUSY is too beautiful to not exist but it is broken heavier and heavier

For the FCC to be built we need overriding reasons which the society can accept for the project to go ahead. Magnets and theory are the main challenges of the FCC.

FCC Placement

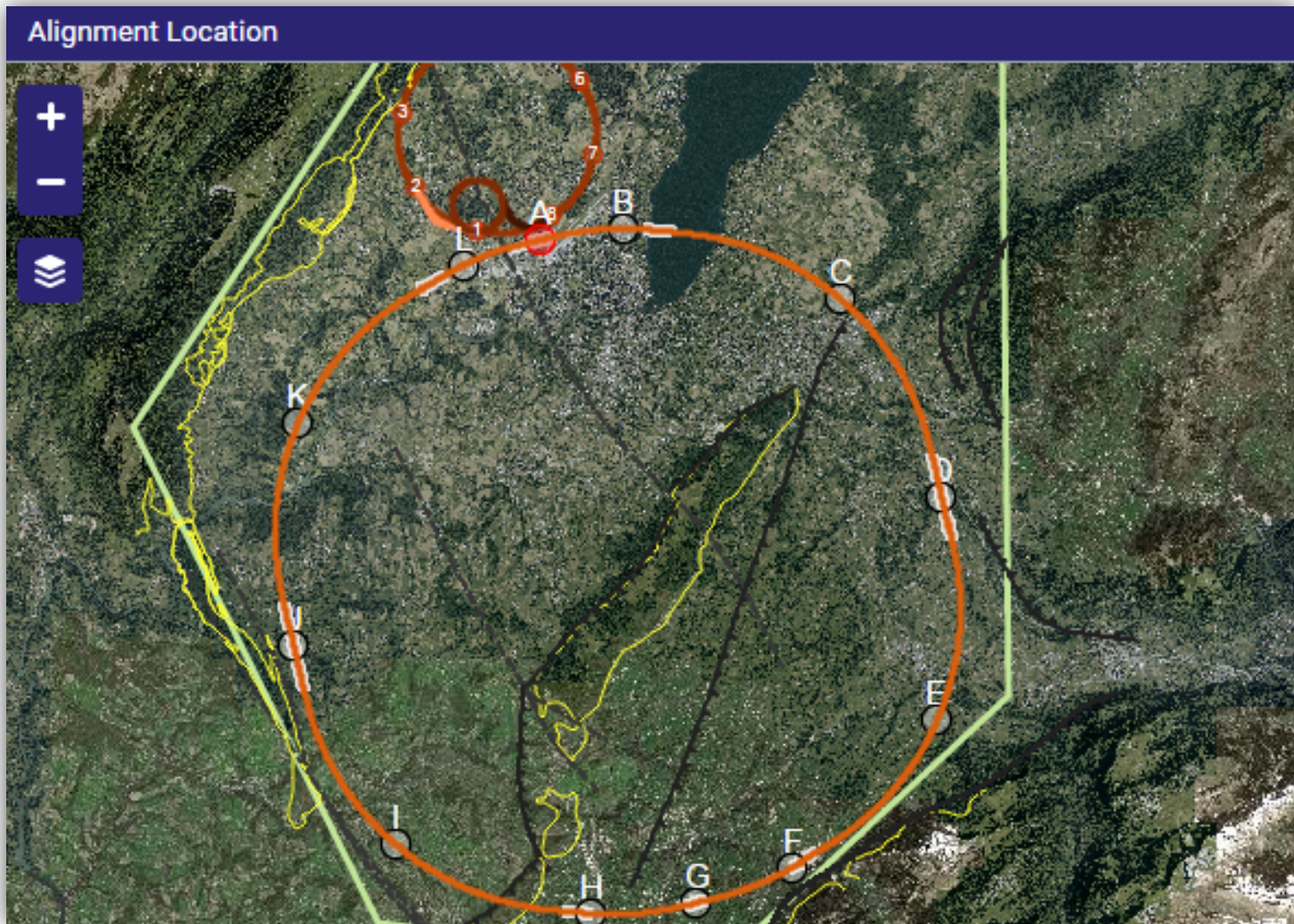

FCC – Dipole Magnets

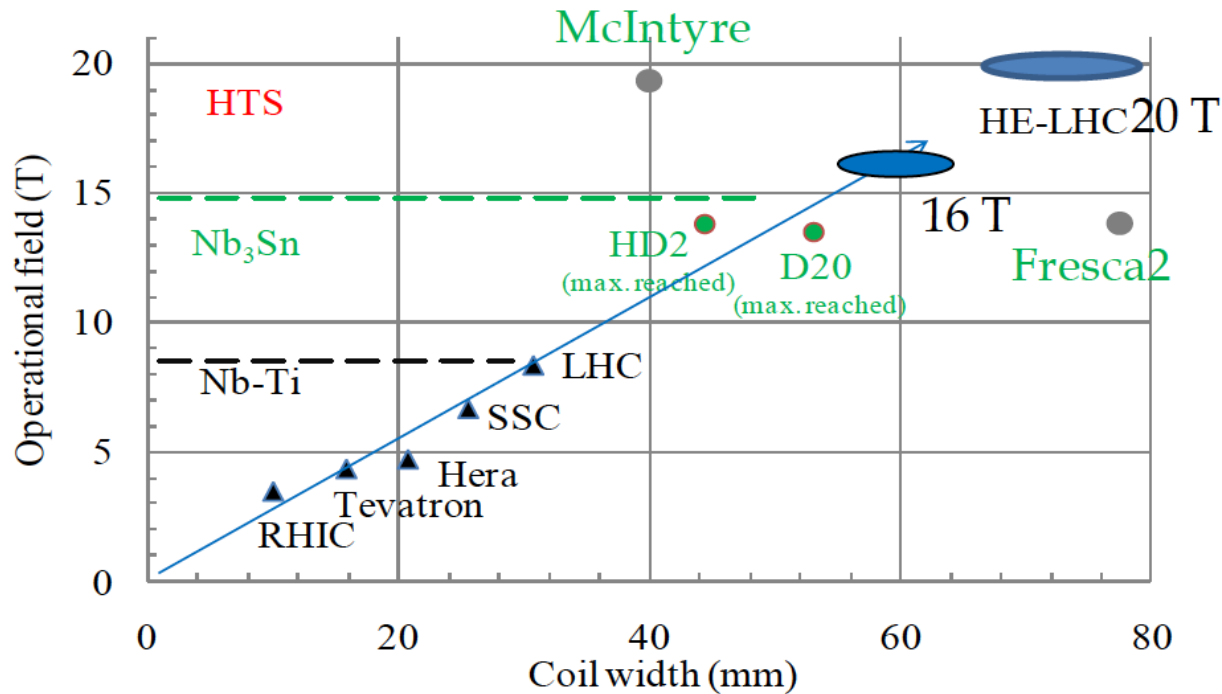

High field SC magnets for HE-LHC as for FCC-hh..

cf E. Todesco
L. Botura et al
at Washington
FCC workshop.
Excessive cost
of Nb₃Sn so far..

Field versus coil width [E. Todesco, L. Rossi, Malta 2011]

LHC	HE-LHC	FCC-hh	FCC-hh
27 km, 8.33 T	27 km, 20 T	80 km, 20 T	100 km, 16 T
14 TeV (c.o.m.)	33 TeV (c.o.m.)	100 TeV (c.o.m.)	100 TeV (c.o.m.)
1300 tons NbTi	3000 tons LTS 700 tons HTS	9000 tons LTS 2000 tons HTS	6000 tons Nb ₃ Sn 3000 tons Nb-Ti

Report of the SSC Collider Dipole Review Panel

June 1989

SSC-SR-1040

G. Voss

Deutsches Elektronen-Synchrotron, DESY
Hamburg, Germany

and

T. Kirk

SSC Central Design Group*
c/o Lawrence Berkeley Laboratory
Berkeley, CA

design. The evaluation was based upon information provided in the scheduled topic presentations, comments and discussion from various Magnet Program personnel, and a set of documents provided by the SSC Magnet Systems Division head: *SSC Magnet R&D Plan 1988*, edited by E. L. Goldwasser; *Development Status for SSC Magnets*, December 1988; *SSC Magnet R&D Plan Update*, January 1989; and the SSC Magnet Program presentations given at the DOE SSC Annual Review, 30 January 1989.

The program goal is to provide a mature design for a 17-m-long magnet that is capable of producing a uniform dipole field with an intensity of 6.6 T at a temperature of 4.35 K and which satisfies all system requirements but is not yet optimized for industrial production. Further

parameter	FCC-ee	LEP2
energy/beam	45 – 175 GeV	105 GeV
bunches/beam	50 – 60000	4
beam current	6.6 – 1450 mA	3 mA
hor. emittance	~2 nm	~22 nm
emittance ratio $\varepsilon_x/\varepsilon_y$	0.1%	1%
vert. IP beta function β_y^*	1 mm	50 mm
luminosity/IP	1.5-280 x $10^{34} \text{ cm}^{-2}\text{s}^{-1}$	0.0012 x $10^{34} \text{ cm}^{-2}\text{s}^{-1}$
energy loss/turn	0.03-7.55 GeV	3.34 GeV
synchrotron radiation power	100 MW	23 MW
RF voltage	.3 – 11 GV	3.5 GV

FCC - ee

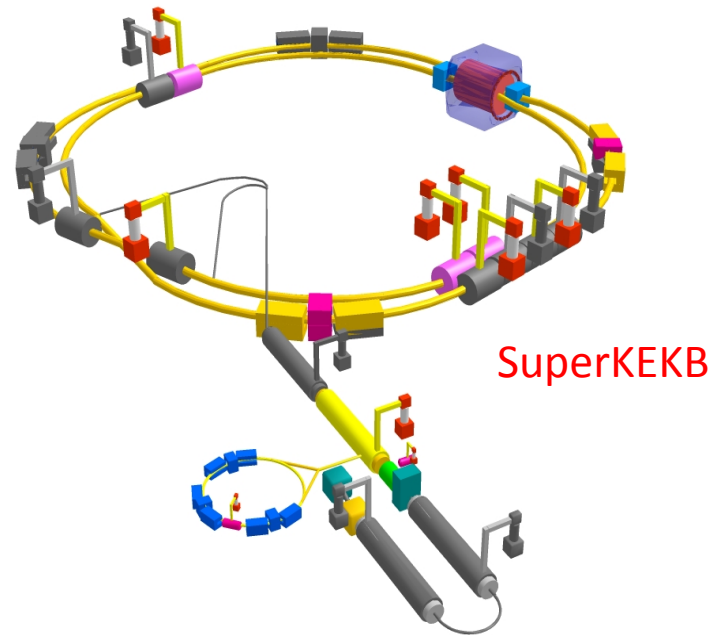

FCC- lifetime of O(10) min – 2 rings
with top up injection

SuperB: ~FCC-ee demonstrator

Z,W,H,t : two decades of operation

SC RF

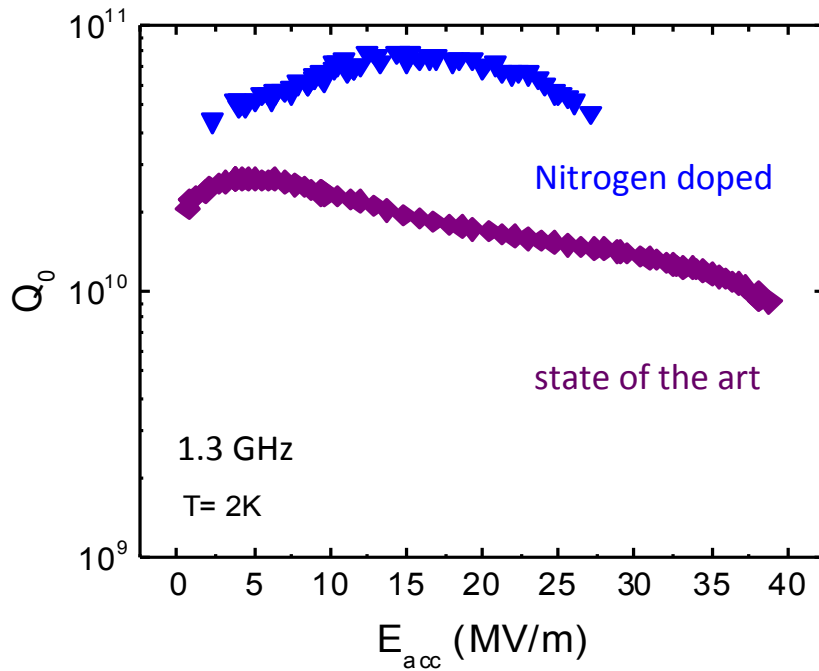

A.Grassellino et al,
2013 Supercond. Sci. Technol. **26** 102001
Rapid Communication – highlights of 2013

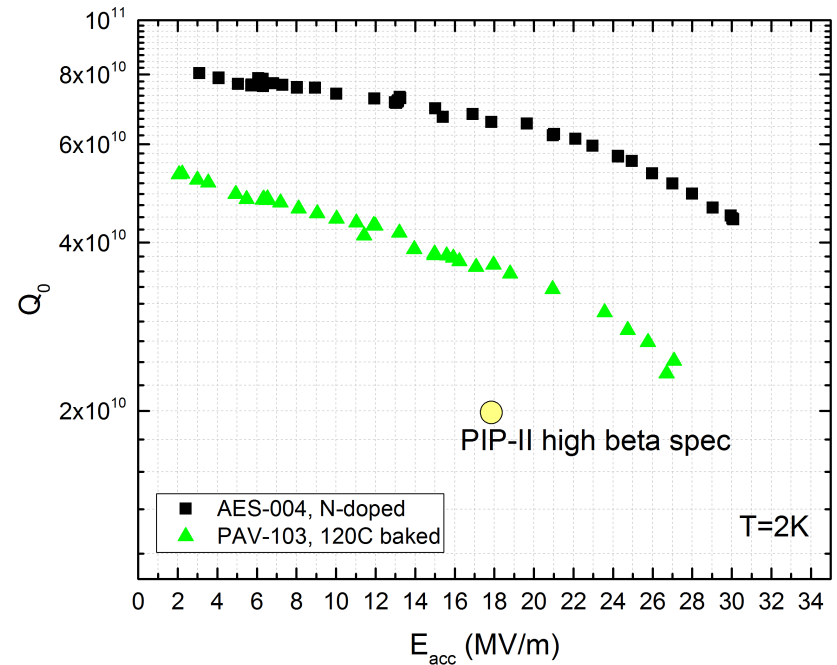

650 MHz Ni doped cavity

Strong development of SC Cavity technology (higher Q_0 , gradient, lower cost)

cf. B Rimmer, E Jensen + at FCC-DC



LHeC HF → FCC-he (phase 1)



parameter [unit]		FCC-hh
species	e-	p
beam energy (/nucleon) [GeV]	60	7000 → 50000
bunch spacing [ns]	25	25
bunch intensity (nucl.) [10¹⁰]	0.4	22 → 10
beam current [mA]	25.6	1110 → 500
normalized rms emittance [μm]	20	2.5 → 2.2
geometric rms emittance [nm]	0.17	0.34 → 0.04
IP beta function $\beta_{x,y}^*$ [m]	0.10 → 0.07	0.05 → 0.3
IP rms spot size [μm]	4.1 → 3.5	4.1 → 3.5
lepton D & hadron ξ	23 → 16	0.0002 → 0.0002
hourglass reduction factor H_{hg}		0.80 → 0.88
pinch enhancement factor H_D		~1.35
luminosity/nucl. [10³³cm⁻¹s⁻¹]		14.4 → 9.9



**Don't trust what you hear
Listen to what you see
This is what will be**

Bruce Springsteen

Many thanks for a wonderful conference, Fred et al

backup

Future Deep Inelastic Scattering

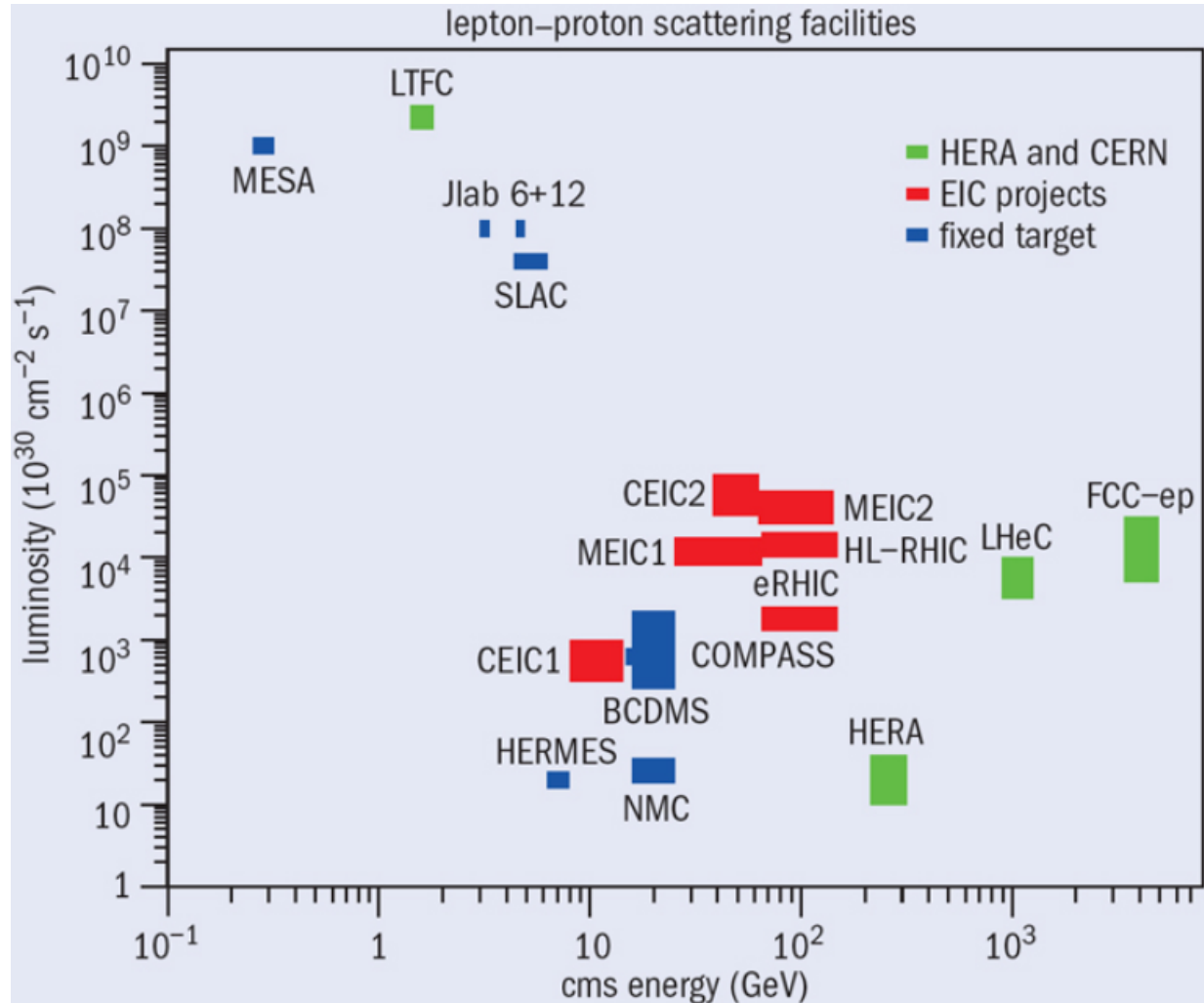

From CERN Courier
MK, H.Schopper
June 2014

With input from
A.Hutton, R.Ent,
F.Maas, T.Rosner

T Han Aspen

* With the Higgs discovery, the SM is healthier than ever, valid to **a scale up to $\Lambda \sim ?$**

But the Higgs sector fine-tuned δ :

* VLHC will take the lead for searches:

$\tilde{g}, \tilde{t}, \tilde{b}, \chi^{\pm,0}, \dots, H^{\pm}, A^0; W^{\pm}, Z' \dots$

The *top, W, Z, H* may hold the key for discovery!

• Searching for **new physics** starts from understanding **old physics in the new regime:**

- *top, W, Z* may behave as partons to produce new heavy states;

- *top, W, Z, H* may serve as new radiation sources;

and may help reveal new heavy states.

- Thus, need precise understanding of the dynamics/kinematics

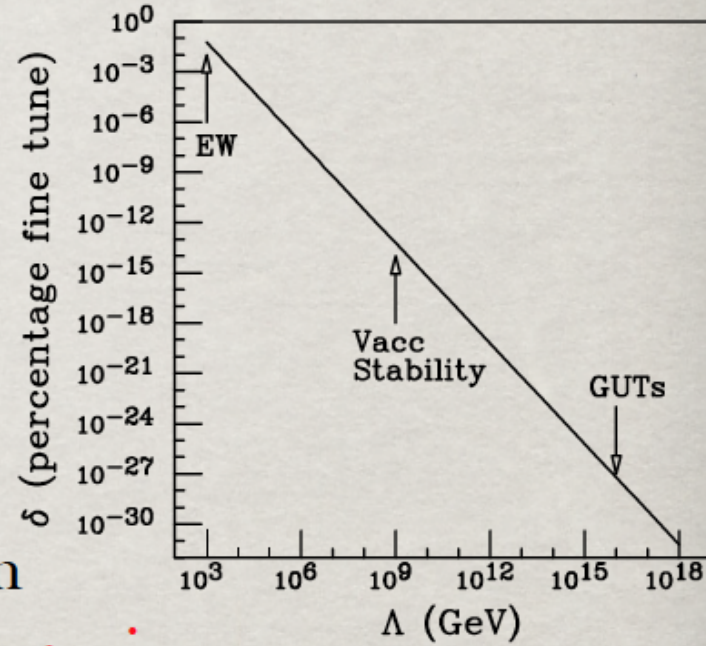

A 25+ years Physics Program

On the beam:

- Perform a comprehensive investigation of neutrino oscillations to:
 - test CP violation in the lepton sector
 - determine the ordering of the neutrino masses
 - test the three-neutrino paradigm
- Perform a broad set of neutrino scattering measurements with the near detector

Exploit the large, high-resolution, underground far detector for non-accelerator physics topics:

- atmospheric neutrino measurements
- searches for nucleon decay
- measurement of astrophysical neutrinos (especially those from a core-collapse supernova).

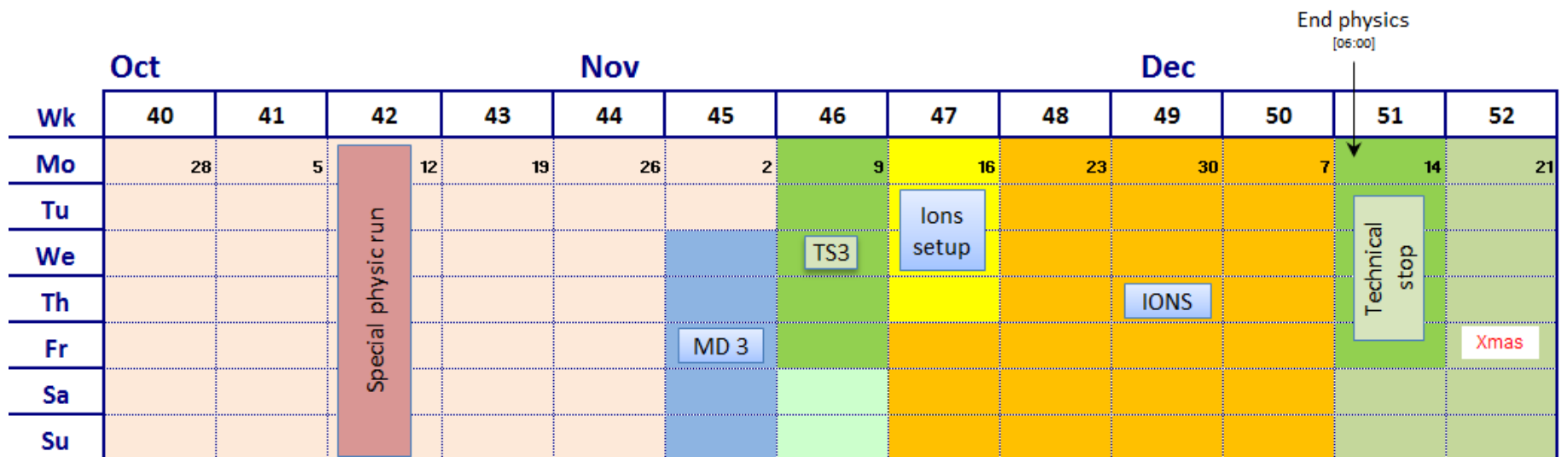
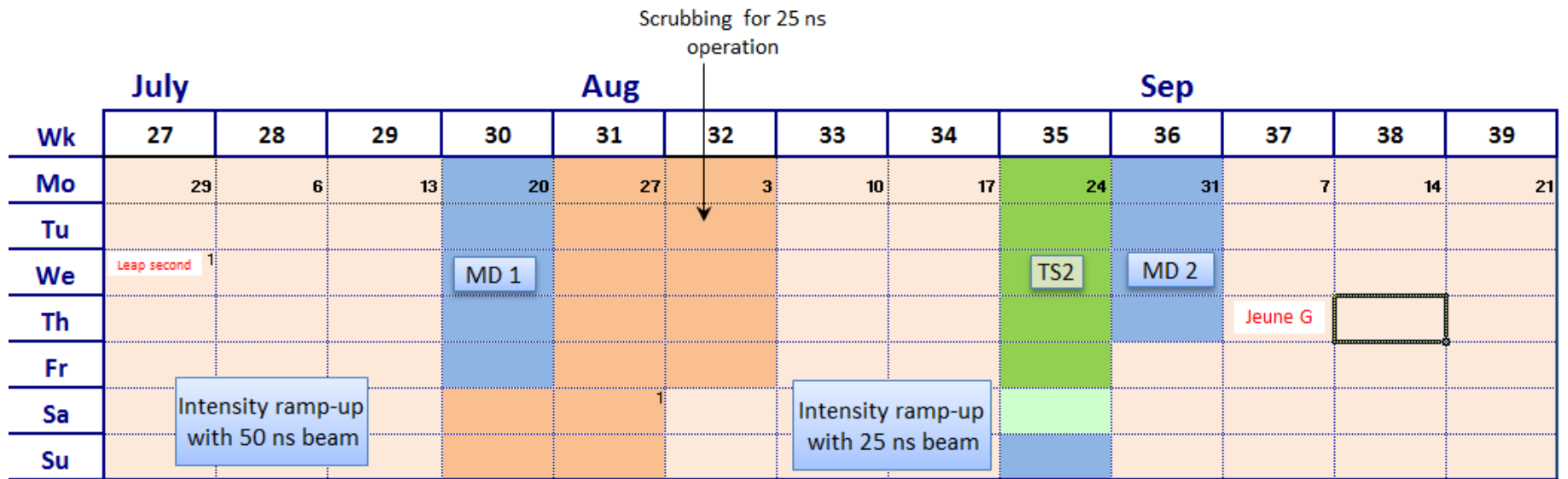

Scenarios for Antiproton Physics Operation in 2017 and 2018



Motivation:

- Detailed Planning for replacement of magnetic lines from AD by electrostatic lines from ELENA
 - Mentioned as one of the next steps for the project at the C&S review in November 2014
 - First versions available now
 - About nine months to remove old and install new lines plus (say) six weeks commissioning
- How much time is left for antiproton physics? Delay new lines to LS2? (questions raised at IEFC)
- Look into possible scenarios for 2017 as a base for discussion

Content:

- Replacement of the magnetic lines from the AD by electrostatic lines from ELENA
- Assumptions
- Possible scenarios for antiproton physics in 2017 and 2018

Conclusions, remarks:

- Installation of new lines from ELENA strongly reduces length of antiproton physics ... but allows more experiments to take beam in parallel and to be more efficient
- Strong dependence on assumptions (ELENA ring ready in autumn 2016 a challenge, LS2 start ..)
- Availability of manpower during LS2?
- Good to be aware of the issue now, but take a decision later (autumn 2016?) with experiments

SHIP Proposal

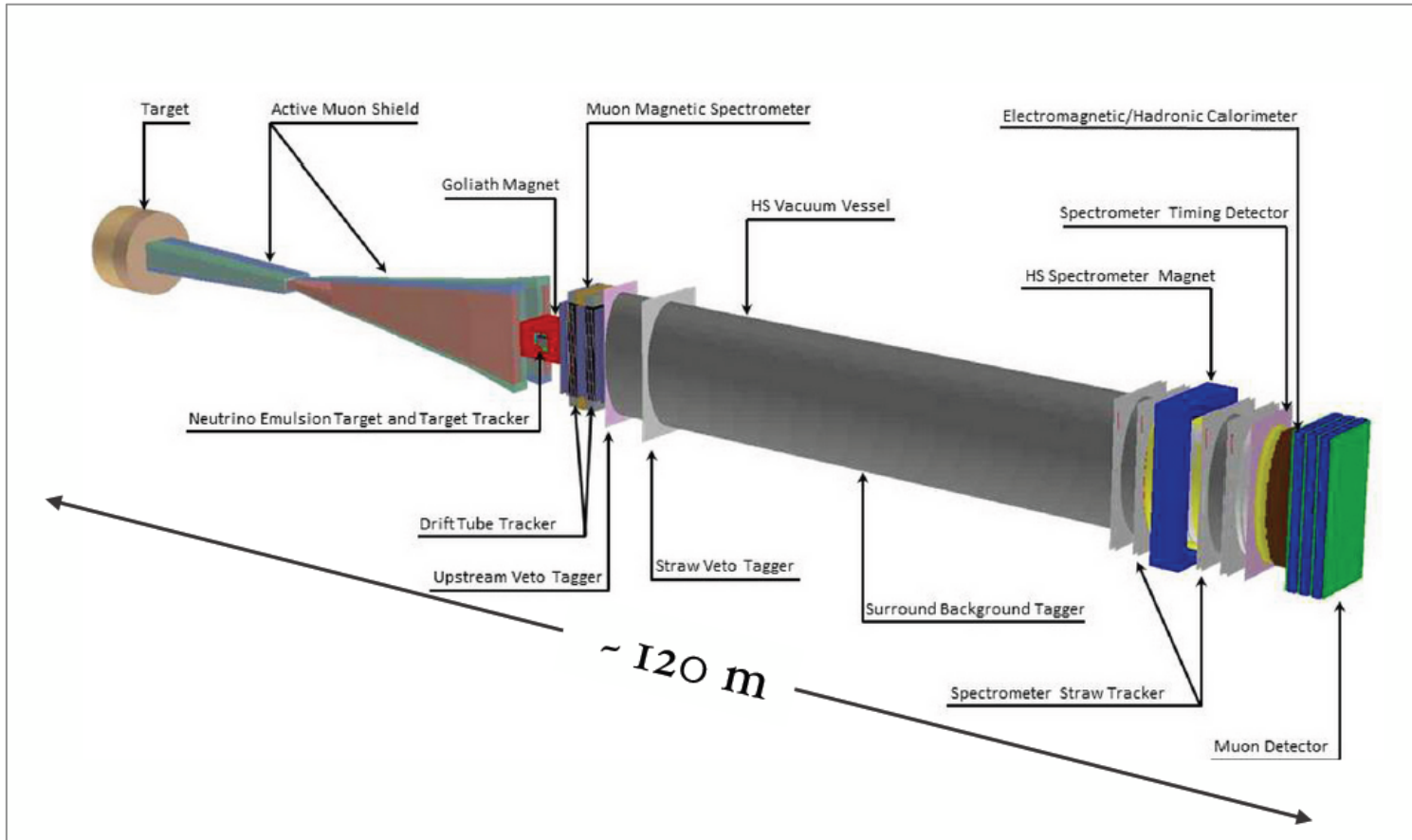

EoI 2013 - CERN Review 2014 - Proposal 2015 - Physics possibly in 2025

Two Reasons for FCC-he

The world's cleanest microscope

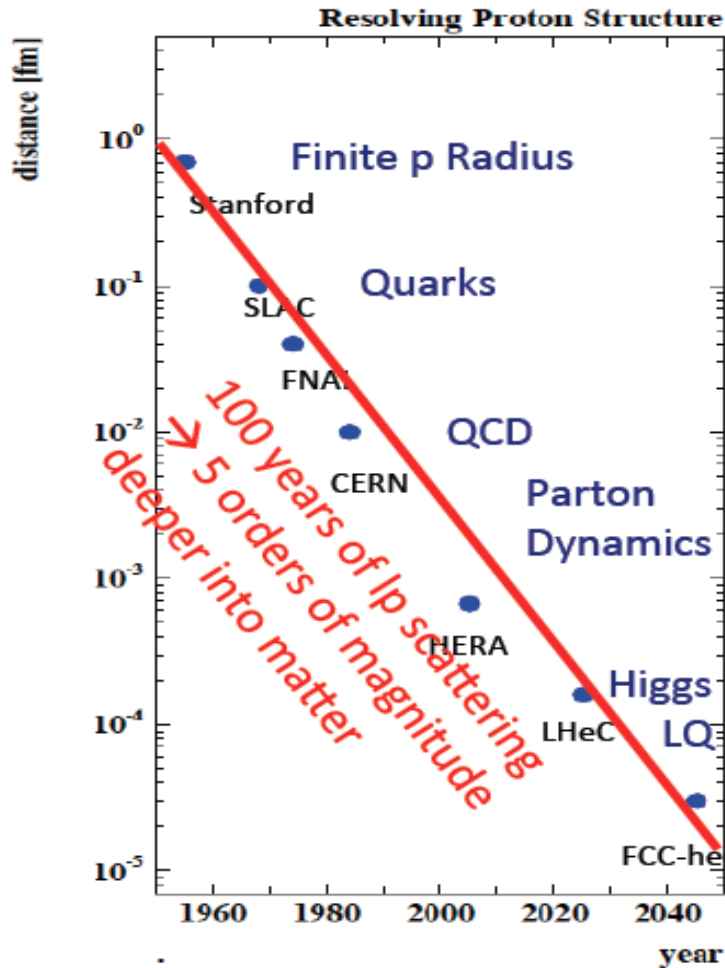

cf F.Olness, V.Radescu, M.Ploskon

New Physics in Higgs, QCD, BSM ($l=q?$)

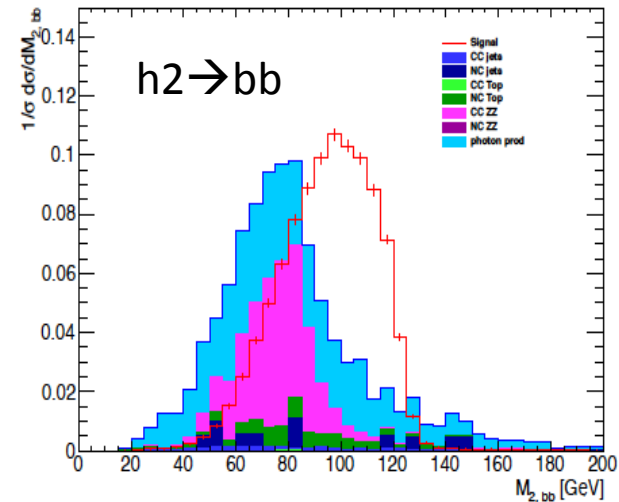
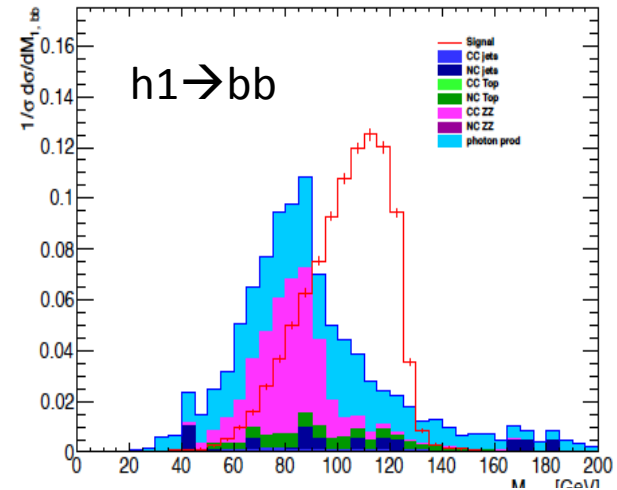

Two h seen in
in new
DELPHES
cut based
analysis of
 h - hh - $4b$
in CC ep
at FCC-he

cf G.Azuolos, M.Klein