

The LHeC – Science and Status



LHeC:
 $E_e = 60 \text{ GeV}$
 $E_p = 7 \text{ TeV}$

Introduction
Five Themes
Important Steps

For references,
please consult
lhec.web.cern.ch

LHeC CDR
arXiv:1206.2913
J.Phys. G39 (2012) 075001

Max Klein
University of Liverpool

for the LHeC+FCC-eh Study Group



FCC_eh:
 $E_e = 60 \text{ GeV}$
 $E_p = 50 \text{ TeV}$

HE LHC:
 $E_p = 12.5 \text{ TeV}$

Road beyond Standard Model

LHC results vital to guide the way at the energy frontier

At the energy frontier through synergy of

hadron - hadron colliders (LHC, (V)HE-LHC?)

lepton - hadron colliders (LHeC ??)

lepton - lepton colliders (LC (ILC or CLIC) ?)

Framework of the Development

Following the CDR in 2012: Mandate issued by CERN:2014 (RH), confirmed in 2016 (FG)

Mandate to the International Advisory Committee

Advice to the LHeC Coordination Group and the CERN directorate by following the development of options of an ep/eA collider at the LHC and at FCC, especially with:

Provision of scientific and technical direction for the physics potential of the ep/eA collider, both at LHC and at FCC, as a function of the machine parameters and of a realistic detector design, as well as for the design and possible approval of an ERL test facility at CERN.

Assistance in building the international case for the accelerator and detector developments as well as guidance to the resource, infrastructure and science policy aspects of the ep/eA collider.

Chair: Herwig Schopper, em. DG of CERN

LHeC has been a development for and initiated by ECFA and NuPECC

Organisation^{*)}

International Advisory Committee

“..Direction for ep/A both at LHC+FCC”

Sergio Bertolucci (CERN/Bologna)
Nichola Bianchi (Frascati)
Frederick Bordry (CERN)
Stan Brodsky (SLAC)
Hesheng Chen (IHEP Beijing)
Eckhard Elsen (CERN)
Andrew Hutton (Jefferson Lab)
Young-Kee Kim (Chicago)
Victor A Matveev (JINR Dubna)
Shin-Ichi Kurokawa (Tsukuba)
Leandro Nisati (Rome)
Leonid Rivkin (Lausanne)
Herwig Schopper (CERN) – Chair
Jurgen Schukraft (CERN)
Achille Stocchi (LAL Orsay)
John Womersley (ESS)

We miss Guido Altarelli.

Coordination Group

Accelerator+Detector+Physics

Nestor Armesto
Oliver Brüning – Co-Chair
Stefano Forte
Andrea Gaddi
Erk Jensen
Max Klein – Co-Chair
Peter Kostka
Bruce Mellado
Paul Newman
Daniel Schulte
Frank Zimmermann

5(11) are members of the
FCC coordination team

OB+MK: FCC-eh responsables
MDO: physics co-convenor

Working Groups

PDFs, QCD

Fred Olness,
Voica Radescu

Higgs

Uta Klein,
Masahiro Kuze

BSM

Georges Azuelos,
Monica D’Onofrio

Top

Olaf Behnke,
Christian
Schwanenberger

eA Physics

Nestor Armesto

Small x

Paul Newman,
Anna Stasto

Detector

Alessandro Polini
Peter Kostka

^{*)}February 2017

Five Major Themes of LHeC PHysics

The Cleanest High Resolution Microscope of the World

The Electron Beam Upgrade of the LHC

The First High Precision Higgs Facility

Discovery Beyond the Standard Model

A Unique Nuclear Physics Facility

Five Major Themes of LHeC PHysics

The Cleanest High Resolution Microscope of the World

The Electron Beam Upgrade of the LHC

The First High Precision Higgs Facility

Discovery Beyond the Standard Model

A Unique Nuclear Physics Facility

Resolving Proton Structure

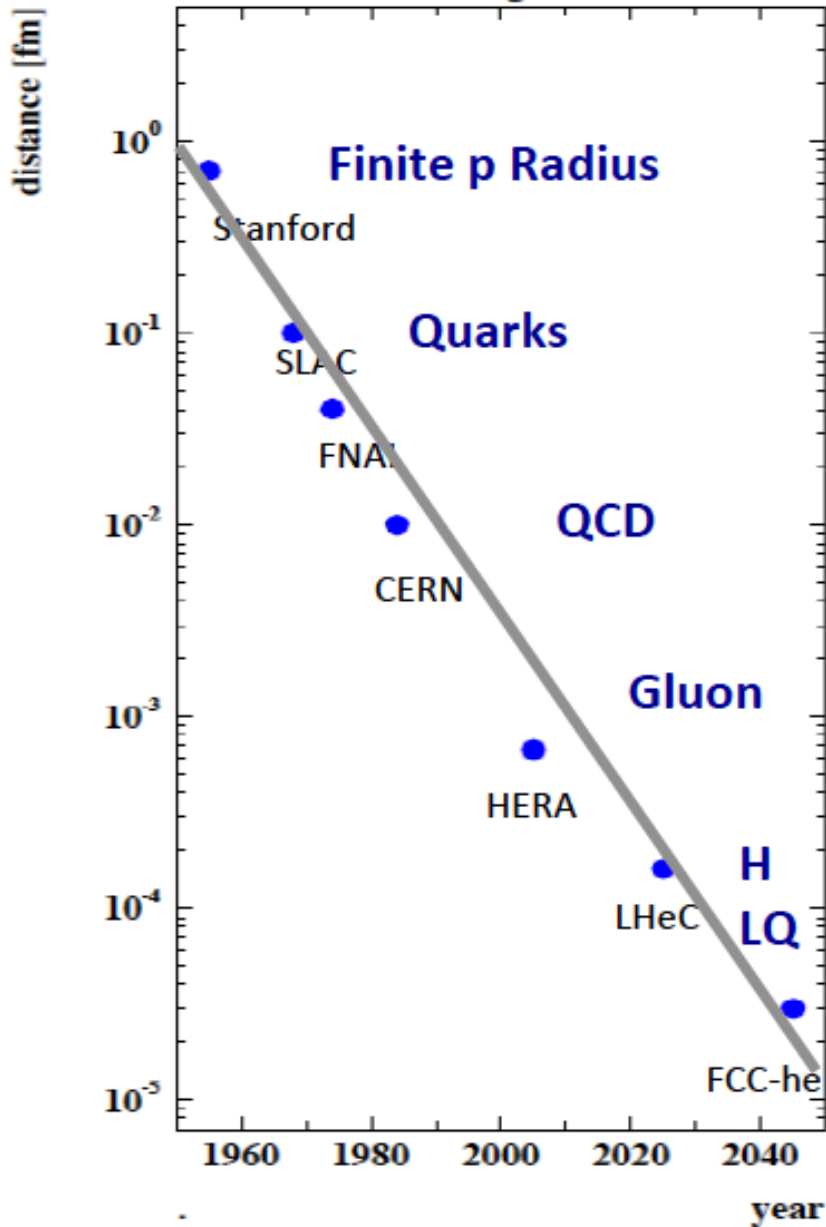

Microscope

Resolve with spectacular range (each high energy ep collider probes range down to SLAC's 0.1fm as Q^2 varies) and precision:

Structure and Dynamics of

Proton, neutron, photon, pomeron, jets..

in Momentum and Transverse Space

PDFs, TMDs, DVCS, generalised PDFs, ..

presented in the LHeC CDR 1206.2913

Short version see arXiv:1211.4831

Can we continue the pass begun 60 years ago for the coming decades?

Prospect and challenge:

5 orders of magnitude in 100 years

The LHeC PDF Programme

Resolve parton structure of the proton completely: $u_v, d_v, s_v, u, d, s, c, b, t$ and xg
Unprecedented range, sub% precision, free of parameterisation assumptions,
Resolve p structure, solve non linear and saturation issues, test QCD, N^3LO ...

Strong
Coupling in
inclusive
DIS at LHeC
to 0.1%

Lattice??
Jets??
BCDMS??
GUTs?
Higgs in pp

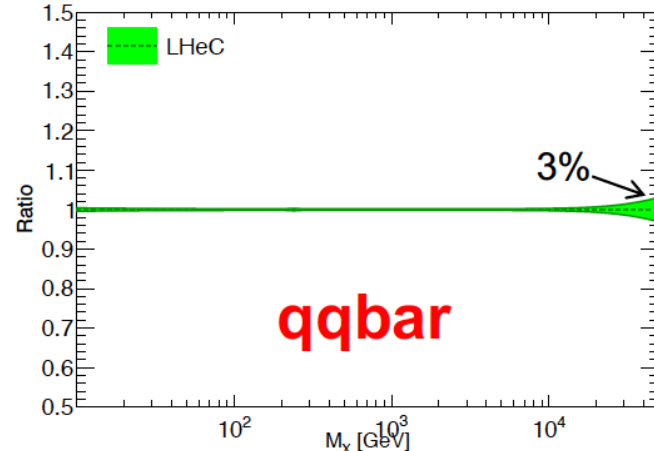
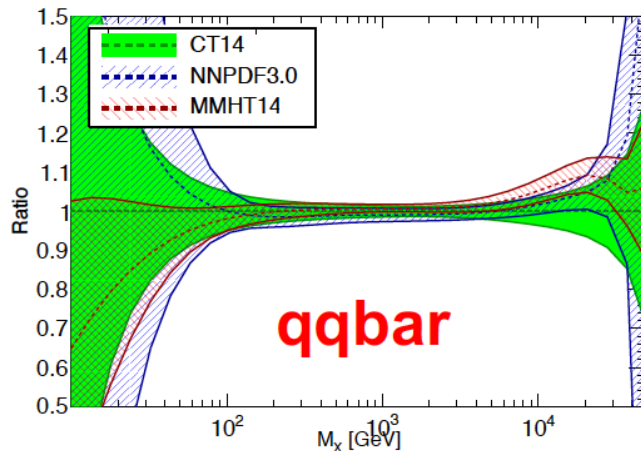

Generated with APPEL 2.7.1 Web

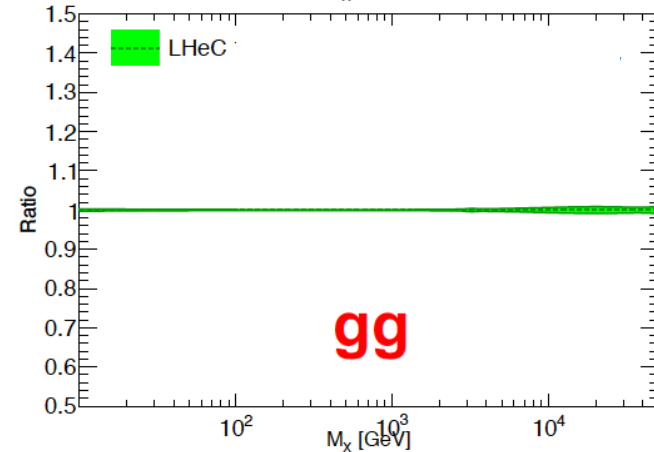
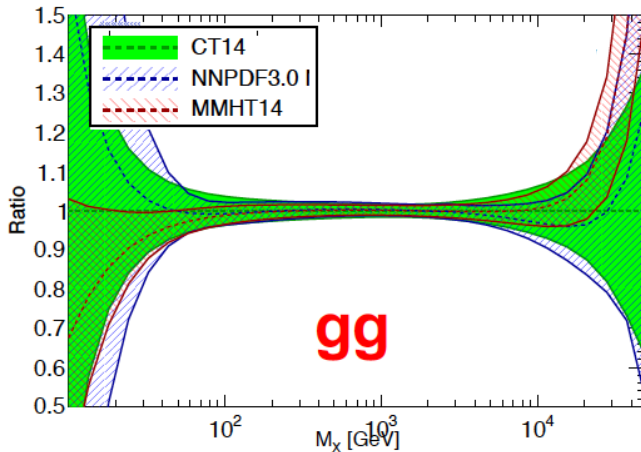

Generated with APPEL 2.7.1 Web

Note that LHC is about to reach its own limits on PDFs. pp is NOT DIS, cf ATLAS W,Z to 0.5%

Top Physics

Top electric charge

EDM and MDM

Anomalous t-q-y and t-g-Z

V_{tb}

Top spin

W-t-b

Top PDF

Top mass

Top-Higgs (1602.04670)

CP nature of ttH (1702.03426)

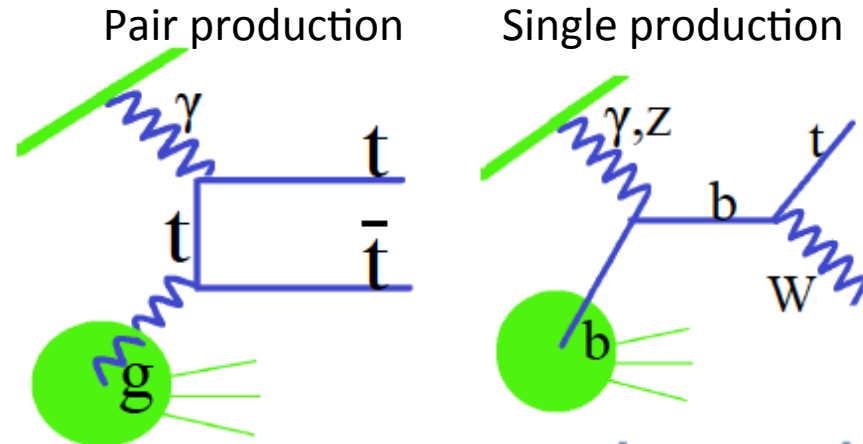

FCNC top Higgs CC interaction

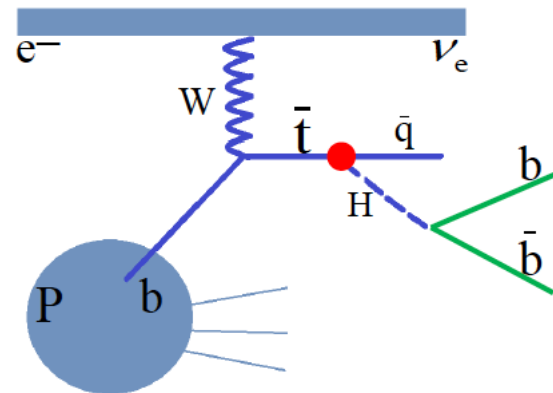

Just started to fully see the huge potential of top physics in ep at high energies

Five Major Themes of LHeC PHysics

The Cleanest High Resolution Microscope of the World

The Electron Beam Upgrade of the LHC

The First High Precision Higgs Facility

Discovery Beyond the Standard Model

A Unique Nuclear Physics Facility

High Precision for the LHC

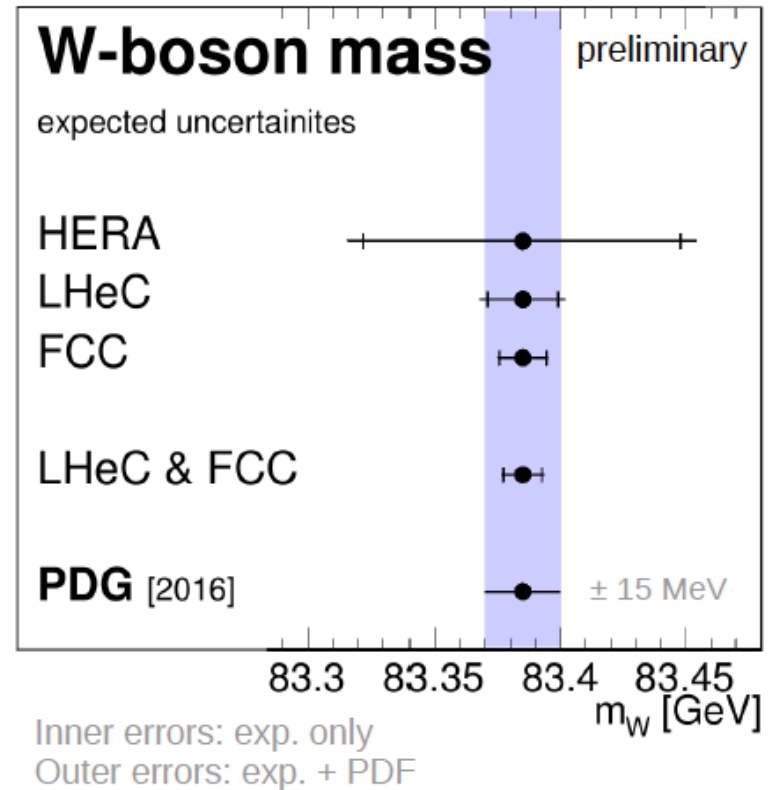
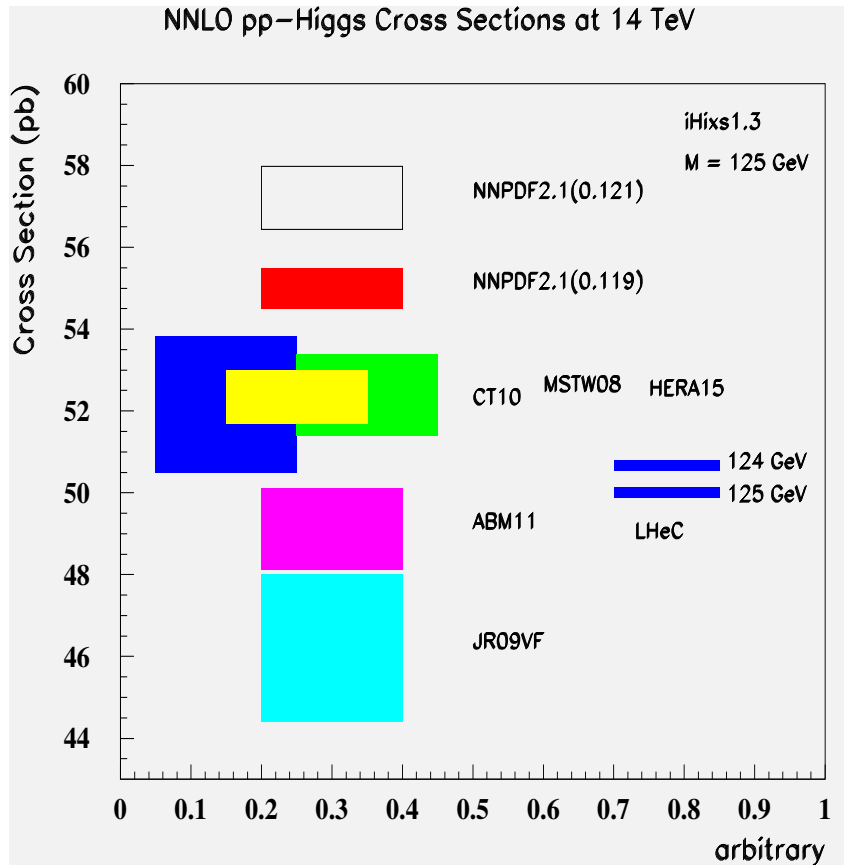

Predict the Higgs cross section in pp to 0.2% precision which matches the M_H measurement and removes the PDF error

Spacelike M_W to 10 MeV from ep
→ Electroweak theory test at 0.01% !

Predict M_W in pp to 2.8 MeV →
Remove PDF uncertainty on M_W LHC

Search Range Extension - worth the Lumi Upgrade

External, reliable input (PDFs, factorisation..) is crucial for range extension + CI interpretation

GLUON

SUSY, RPC, RPV, LQS..

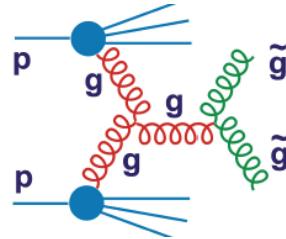

QUARKS

Exotic+ Extra boson searches at high mass

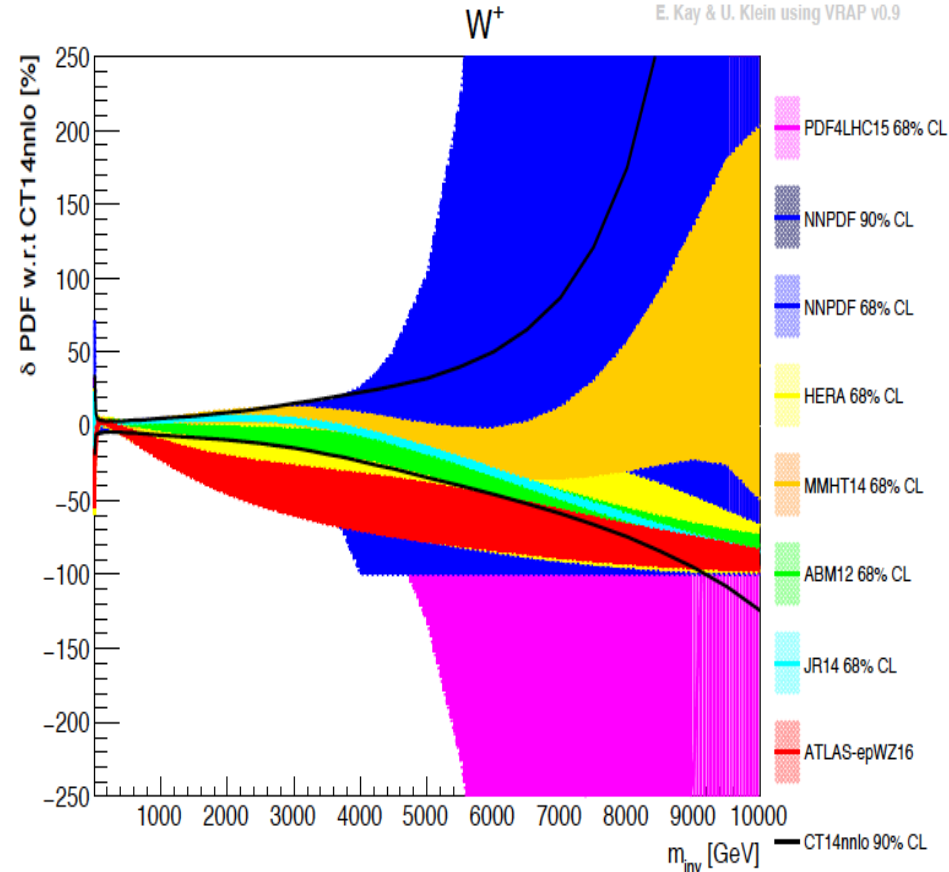
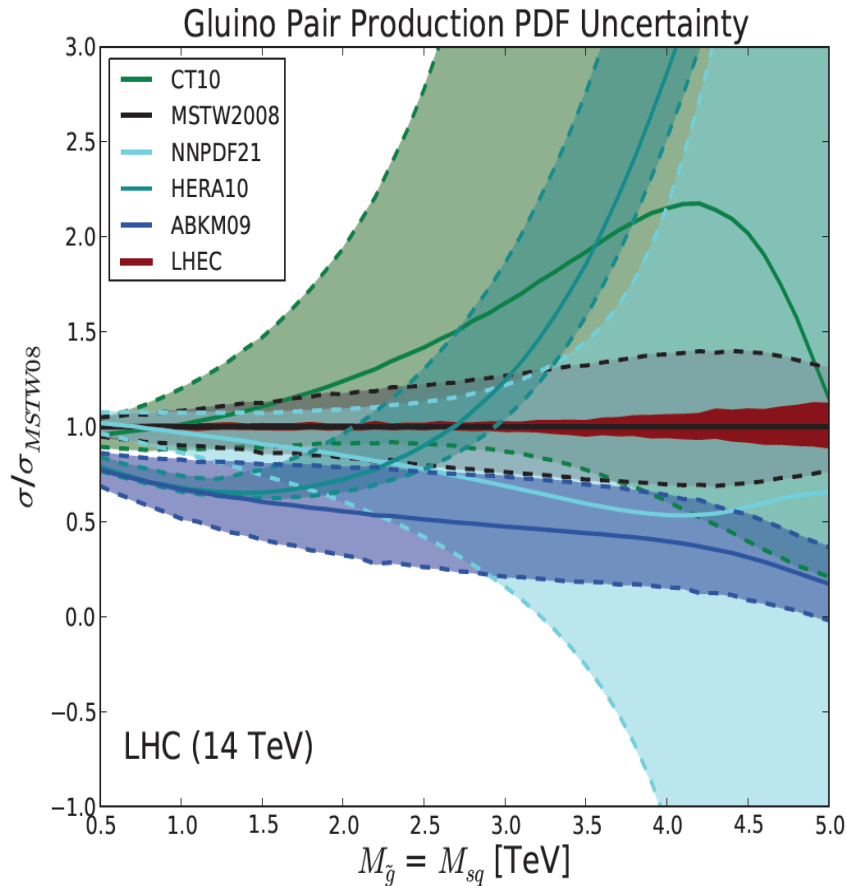

Five Major Themes of LHeC PHysics

The Cleanest High Resolution Microscope of the World

The Electron Beam Upgrade of the LHC

The First High Precision Higgs Facility

Discovery Beyond the Standard Model

A Unique Nuclear Physics Facility

Higgs Physics with ep

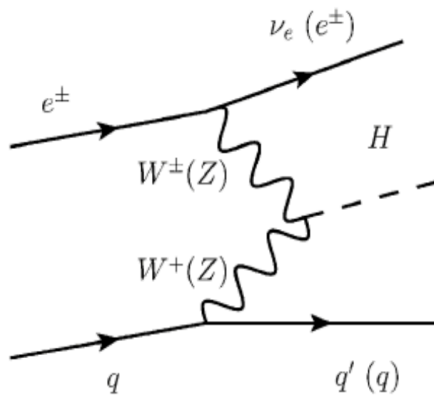

κ in %	HL LHC	LHeC HL	LHeC HE	FCC-eh
$H \rightarrow bb$	10	0.5	0.3	0.2
$H \rightarrow cc$	50?	4	2.8	1.8

- Higgs is produced via an EW process in ep collisions
 - **No contamination from ggF and no pile-up**
 - **Precise theoretical control of the cross-section**
- Superior sensitivity of ep with respect to pp in various aspects:
 - **$h \rightarrow bb, cc, \tau\tau$ couplings, unique access to WW-H-WW**
 - **Access to $h \rightarrow gg$?**
 - **Structure of hVV and top Yukawa couplings**
- Access to hh and invisible decays (dark matter) in ep collisions
- Removal of QCD uncertainties to $gg \rightarrow H$ calculation for LHC
- **LHC can be transformed into a high precision Higgs facility.**

Five Major Themes of LHeC PHysics

The Cleanest High Resolution Microscope of the World

The Electron Beam Upgrade of the LHC

The First High Precision Higgs Facility

Discovery Beyond the Standard Model

A Unique Nuclear Physics Facility

Possible Discoveries Beyond SM with LHeC

Search for Sterile Neutrinos (LHC LHeC)

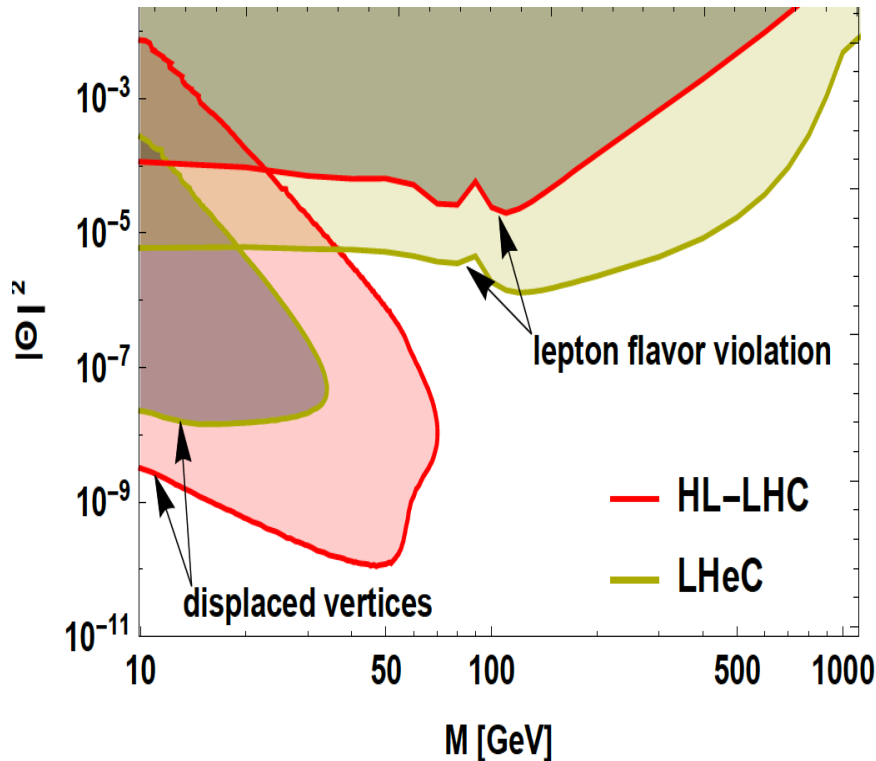

It is a wasted p that does NOT collide with an e beam
(Oliver Fischer - 2017)

It would be a waste not to exploit the 7 TeV beams for ep and eA physics at some stage during the LHC time (Guido Altarelli - 2008)

QCD:

No saturation

BFKL

Instantons

Higher symmetry embedding QCD

Electroweak:

EFTs

Exotic Higgs Decays

Extension of Higgs Sector

Sterile Neutrinos ...

Five Major Themes of LHeC PHysics

The Cleanest High Resolution Microscope of the World

The Electron Beam Upgrade of the LHC

The First Higgs and Top Precision Facility

Discovery Beyond the Standard Model

A Unique Nuclear Physics Facility

Electron-Ion Nuclear and Particle Physics

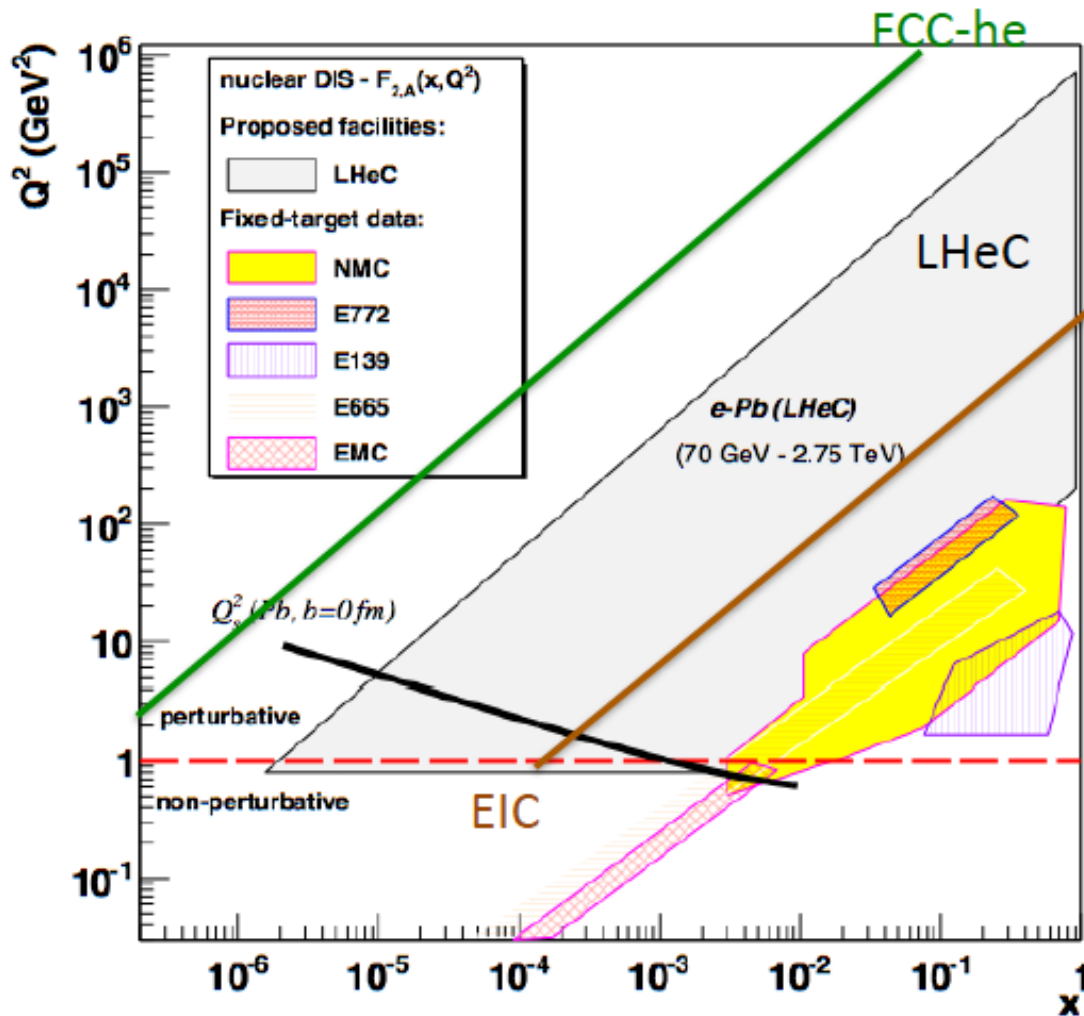

Extension of kinematic range in IA by 4 orders of magnitude:

will change QCD view on nuclear structure and parton dynamics

May lead to genuine surprises...

- No saturation of $xg(x, Q^2)$?
- Small fraction of diffraction ?
- Broken isospin invariance ?
- Flavour dependent shadowing ?

Relates to LHC Heavy Ion Physics

- Quark Gluon Plasma
- Collectivity of small nuclei (p)?
- ..

Saturation: needs large xg at small x ep and eA

Design and Preparations

LHeC ERL Baseline Design

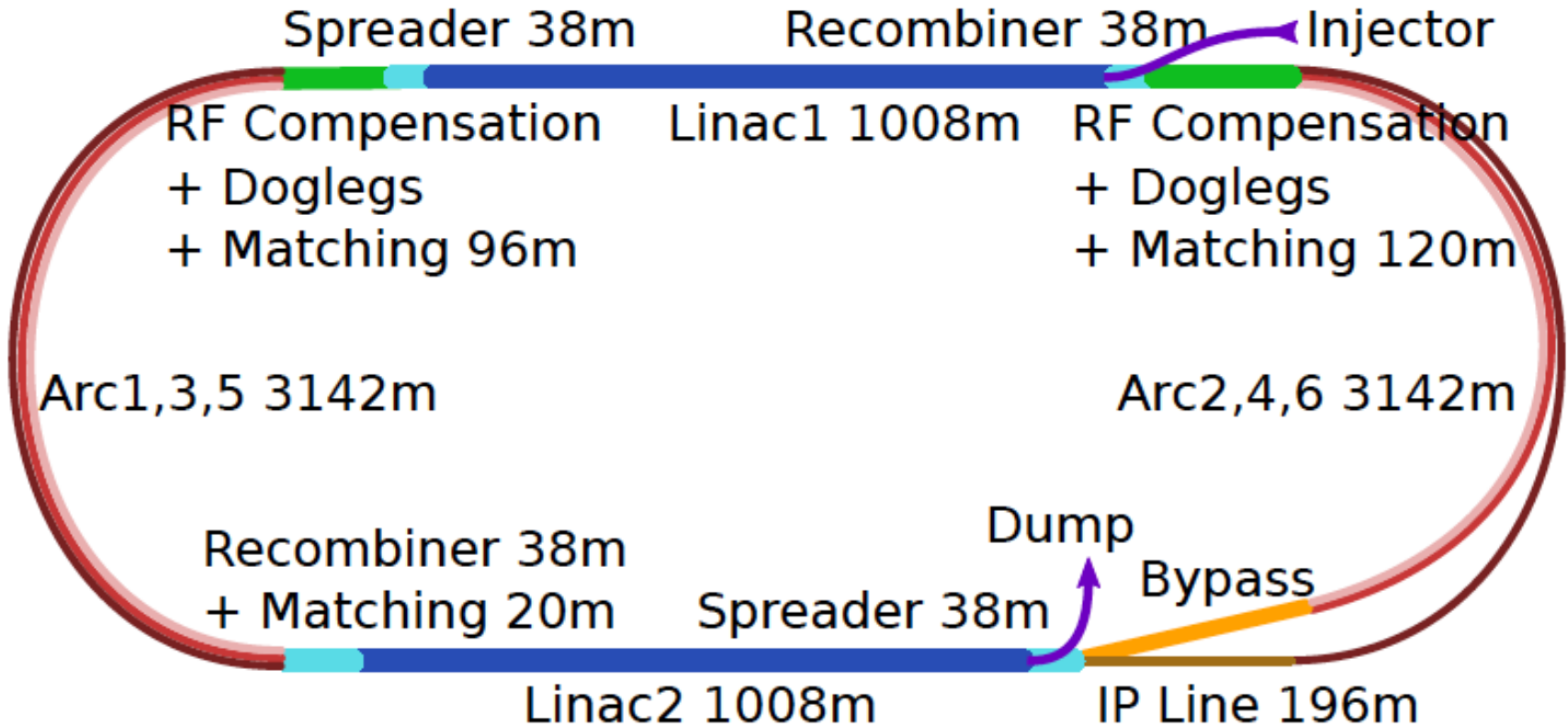

Concurrent operation to pp, LHC becomes a 3 beam facility. $P < 100$ MW. CW

Luminosity for LHeC, HE-LHeC and FCC

parameter [unit]	LHeC CDR	ep at HL-LHC	ep at HE-LHC	FCC-he
E_p [TeV]	7	7	12.5	50
E_e [GeV]	60	60	60	60
\sqrt{s} [TeV]	1.3	1.3	1.7	3.5
bunch spacing [ns]	25	25	25	25
protons per bunch [10^{11}]	1.7	2.2	2.5	1
$\gamma\epsilon_p$ [μm]	3.7	2	2.5	2.2
electrons per bunch [10^9]	1	2.3	3.0	3.0
electron current [mA]	6.4	15	20	20
IP beta function β_p^* [cm]	10	7	10	15
hourglass factor H_{geom}	0.9	0.9	0.9	0.9
pinch factor H_{b-b}	1.3	1.3	1.3	1.3
proton filling H_{coll}	0.8	0.8	0.8	0.8
luminosity [$10^{33}\text{cm}^{-2}\text{s}^{-1}$]	1	8	12	15

Oliver Brüning¹, John Jowett^{1,2}, Max Klein^{1,2},
Dario Pellegrini¹, Daniel Schulte¹, Frank Zimmermann¹

¹ CERN, ² University of Liverpool

April 6th, 2017

Location + Footprint of the **electron ERL**

LHC



FCC

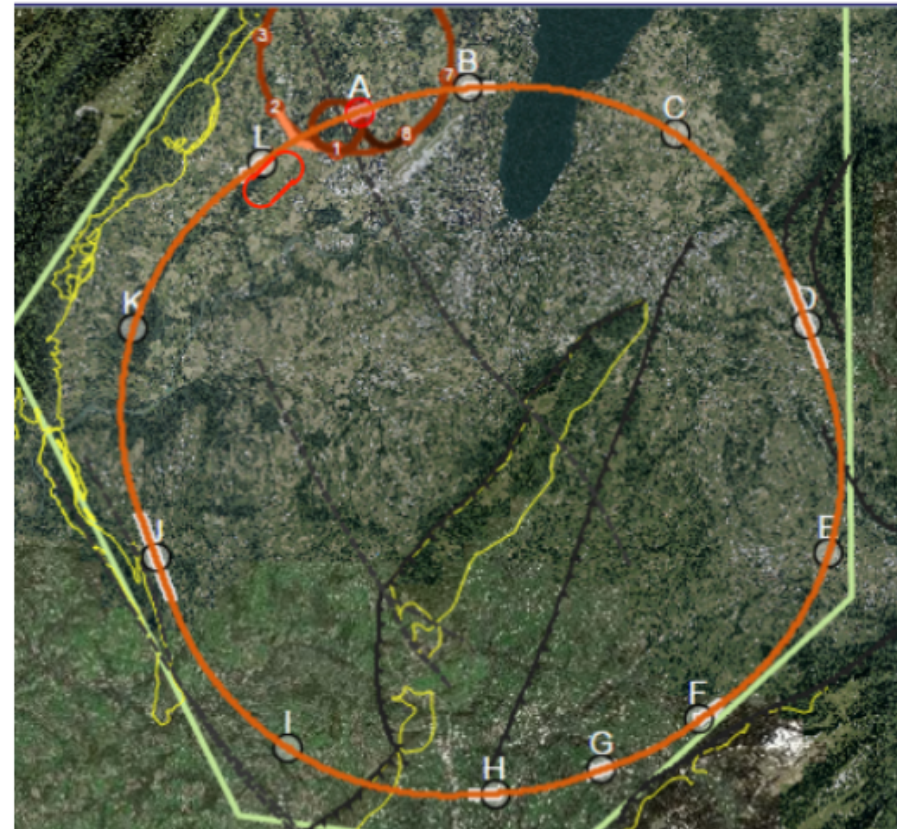

**A 9km ERL is a small add-on for the FCC
Doubling the energy to 120 GeV hugely
Increases cost and effort.**

**Energy – Cost – Physics – Footprint
are being reinvestigated**

Civil Engineering – full design made

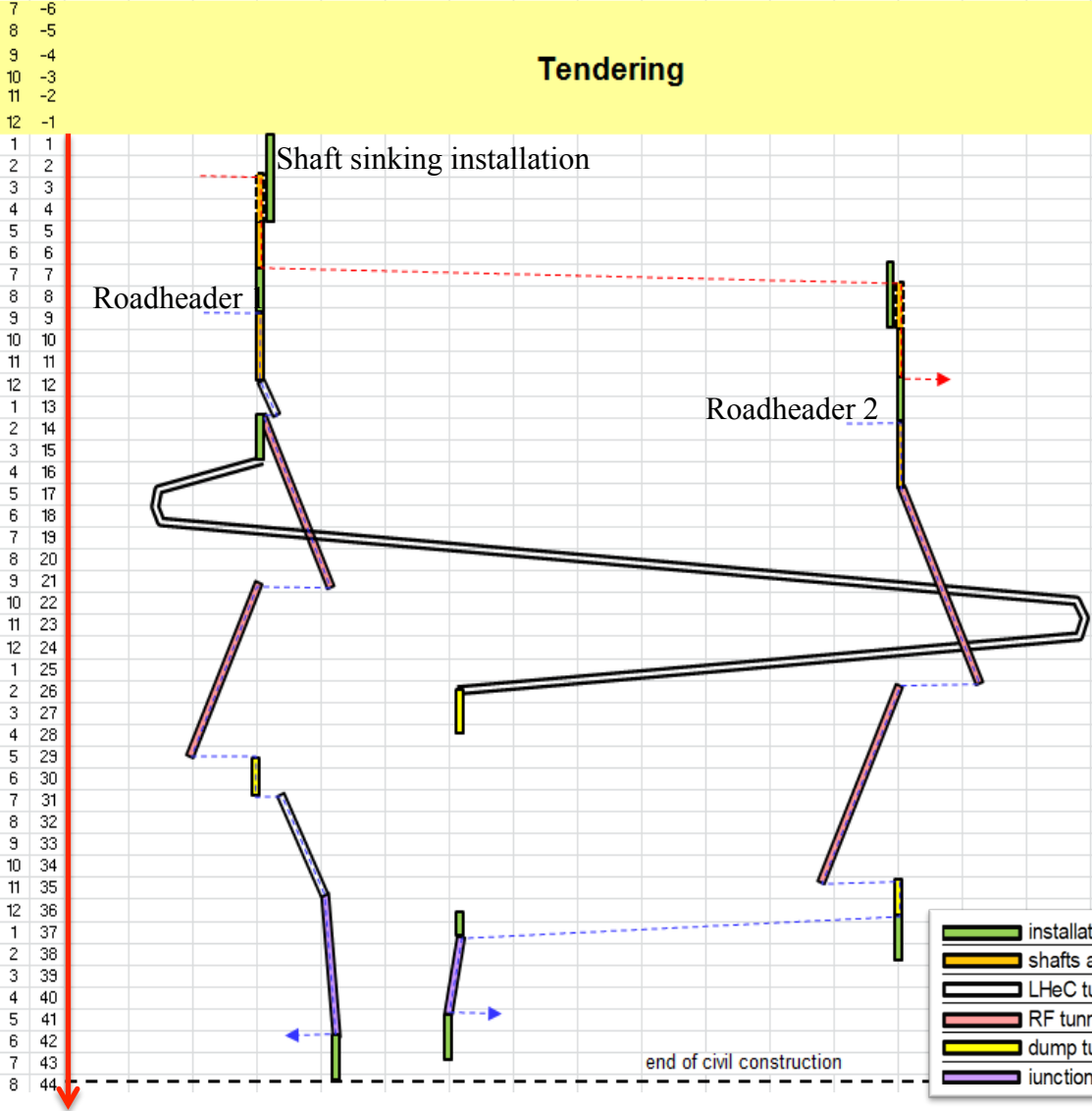

CDR: Evaluation of CE, analysis of ring and linac by Amber Zurich with detailed cost estimate [linac CE: 249,928 kSF..] and time: **3.5 years for underground works** using 2 roadheaders and 1 TBM

More studies needed for
Integration with all services (EL,CV, transport, survey etc).
Geology
Understanding vibration risks
Environmental impact assessment

Tunnel connection in IP2

LABORATOIRE DE L'ACCÉLÉRATEUR LINÉAIRE



PERLE TDR Kickoff Meeting, Orsay, February 22-24, 2017. PERLE CDR subm to JPhysG

Powerful ERL for Experiments (ep.y): PERLE at Orsay

PERLE at Orsay: New Collaboration: BINP, CERN, Daresbury/Liverpool, Jlab, Orsay +

CDR publication imminent.

3 turns, 2 Linacs, 15mA, 802 MHz ERL facility

- Demonstrator of LHeC
- Technology (SCRF) Development Facility
- Low E electron and photon beam physics
- High intensity: 100 x ELI

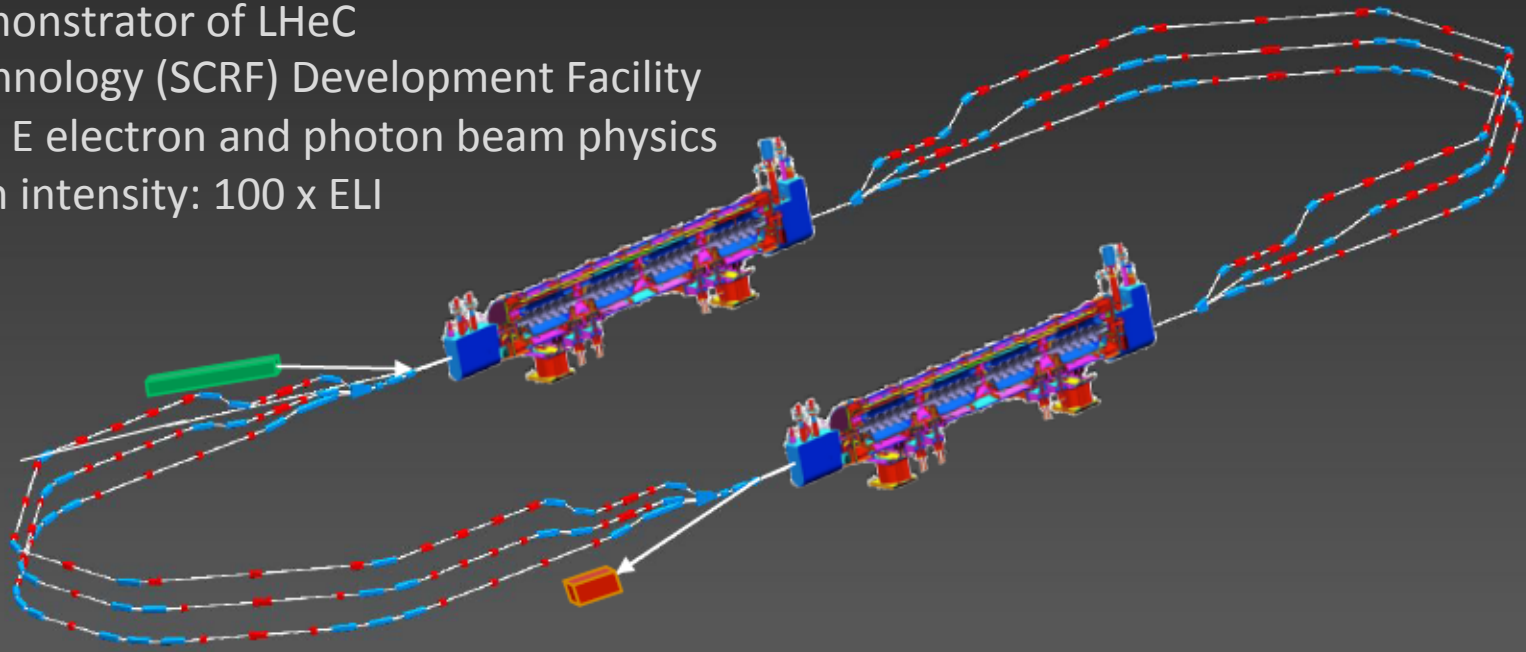

$H \rightarrow b\bar{b}$ in LHeC Detector

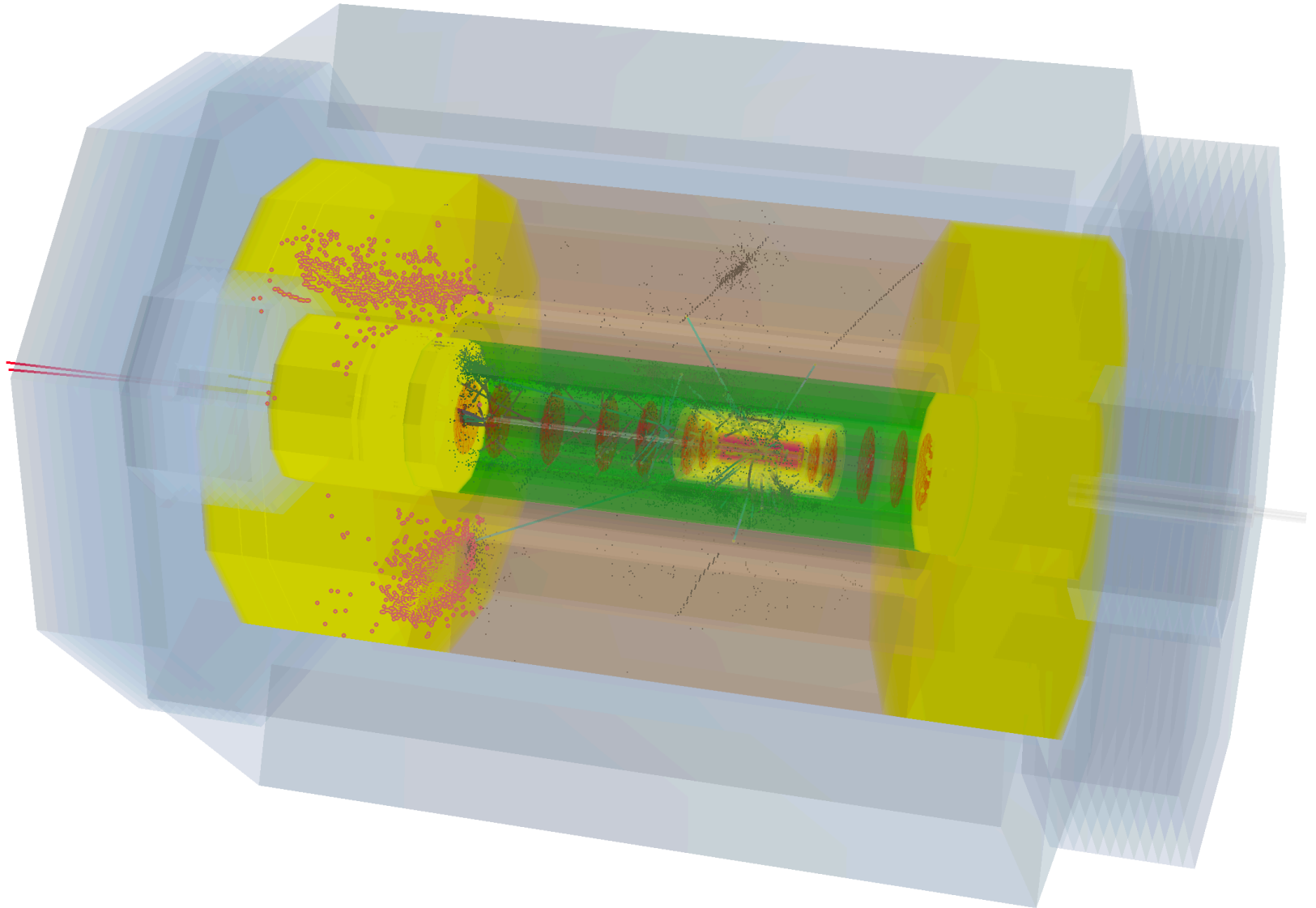

*“The future belongs to those who believe
in the beauty of their dreams.”*

Anna Eleanor Roosevelt
(1884-1962)



Universal Declaration of Human Rights (1948)

cited by Frank Zimmermann at the FCC Meeting at Washington DC, March 2015

CERN can do pp and lp: in the 80ies it successfully did

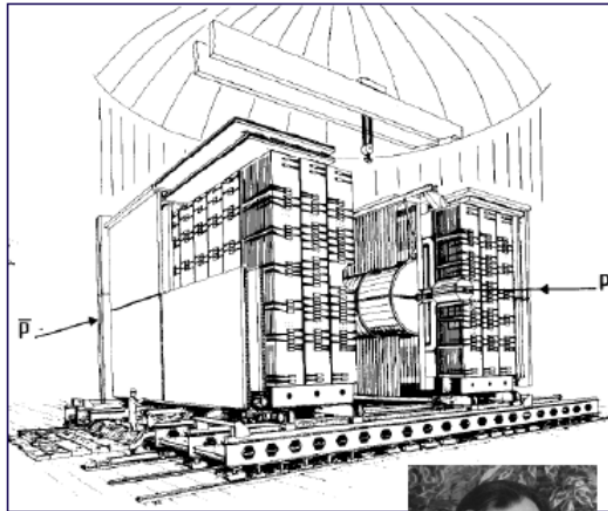

UA1



“ We have two tasks: kill Weinberg Salam, kill QCD”
Carlo Rubbia: 1978 BCDMS meeting at Dubna.
The failure to fulfill his task made Carlo famous...



UA2

Pierre Darriulat
now in Vietnam

Charged Currents



BEBC, CDHS(W), CHARM, CHORUS

Neutral Currents

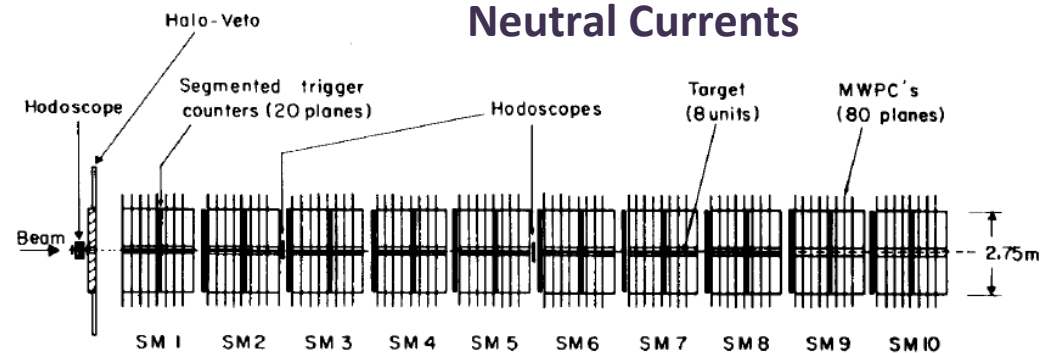

BCDMS, EMC, SMC, COMPASS

Electron-Hadron Scattering at the Energy Frontier – A Higgs Physics Facility Resolving the Substructure of Matter

Draft Table of Contents (9. June 2016)

1. Introduction: The LHC, Modern Particle Physics and the Rôle of ep/eA
2. Physics: QCD/PDFs, Higgs, top, BSM, small x, eA at the LHeC; key items at 1.9/3.4 TeV
3. ERL electron beam: Design, Components, Injector, Dump, Civil Engineering ..
4. LHeC Performance: Collider Parameters, Luminosity, Joint Operation, Infrastructure..
5. Detector: Machine Interface (IR), Design and Performance, Components, Software
6. Installation of the Machine and Detector
7. Summary

Appendix:

- Status of the LHeC Demonstrator and ERL Developments
- Cost-Energy Relation and Cost Estimate for LHeC
- Detector Cost Estimate
- Extensions into the HE LHC Phase
- Electron-Hadron Scattering with the FCC (link to FCC CDR)

**In agreement with DG we
Work on an update of the
LHeC CDR as input to Euro
Strategy. We find it is worth
it the deeper we look.**

**We'd be glad to have many
of you with us.**

Update of the LHeC CDR^{*)} and input to EU Particle and Nuclear Physics Strategy

*) [arXiv:1206.2913](https://arxiv.org/abs/1206.2913)

The LHeC – Science + Status