

A piece of layered rock, possibly a sedimentary or metamorphic rock, with various shades of brown, tan, and grey. The rock has a rough, irregular shape and shows signs of fracturing and layering. The text is overlaid on the rock in a purple color.

MAGNETIC MONOPOLES AT THE LHC AND IN THE COSMOS

PHILIPPE MERMOD
PARTICLE PHYSICS SEMINAR
UNIVERSITY OF LIVERPOOL
19 FEBRUARY 2014

MONOPOLE – THE BASICS

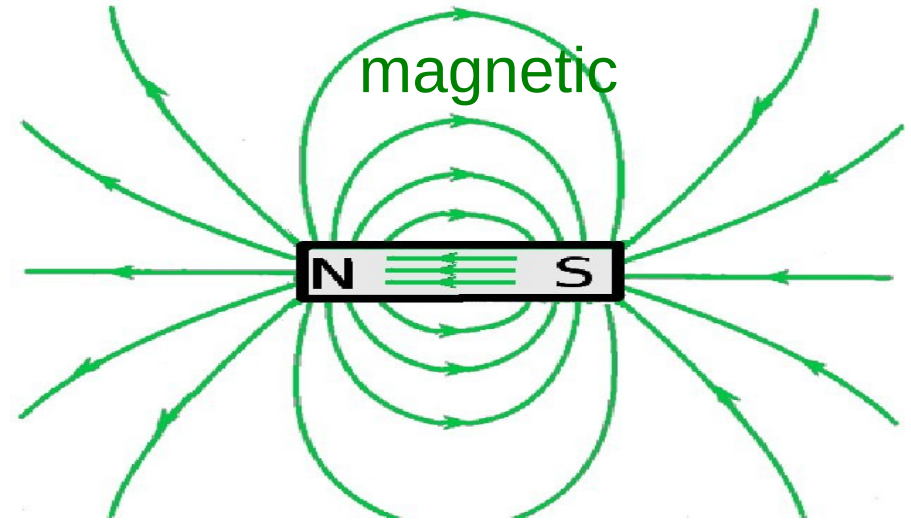
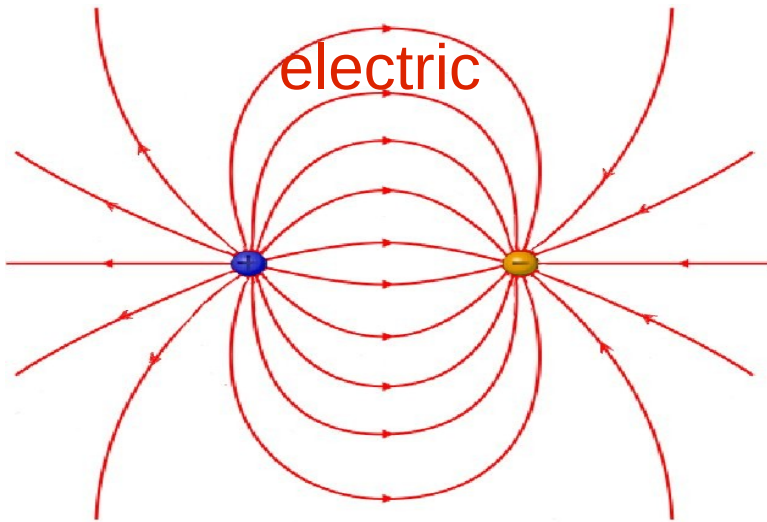

Sources of electric field exist (e.g. electrons, protons)

– Are there magnetic equivalents?

proton

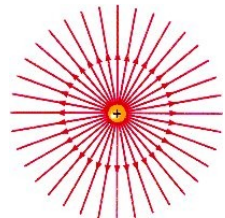

magnetic monopole



MAXWELL'S EQUATIONS

(1862)

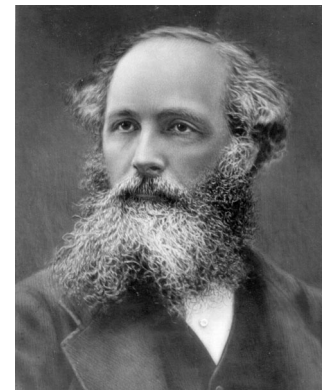

Without monopoles

$$\nabla \cdot \mathbf{E} = 4\pi\rho_e$$

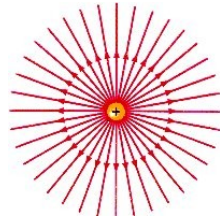

$$\nabla \cdot \mathbf{B} = 0$$

$$-\nabla \times \mathbf{E} = \frac{1}{c} \frac{\partial \mathbf{B}}{\partial t}$$

$$\nabla \times \mathbf{B} = \frac{1}{c} \frac{\partial \mathbf{E}}{\partial t} + \frac{4\pi}{c} \mathbf{j}_e$$

With monopoles

$$\nabla \cdot \mathbf{E} = 4\pi\rho_e$$

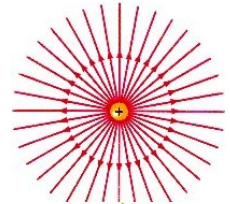

$$\nabla \cdot \mathbf{B} = 4\pi\rho_m$$



$$-\nabla \times \mathbf{E} = \frac{1}{c} \frac{\partial \mathbf{B}}{\partial t} + \frac{4\pi}{c} \mathbf{j}_m$$

$$\nabla \times \mathbf{B} = \frac{1}{c} \frac{\partial \mathbf{E}}{\partial t} + \frac{4\pi}{c} \mathbf{j}_e$$

DIRAC's ARGUMENT

Proc. Roy. Soc. A 133, 60 (1931)

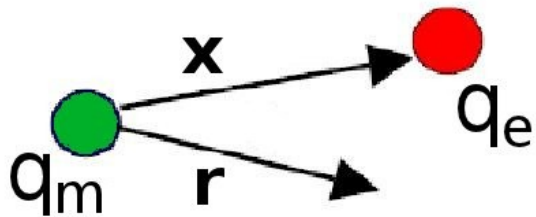

$$\mathbf{L} = \int \mathbf{r} \times \mathbf{E} \times \mathbf{B} d\mathbf{r} = \frac{\mu_0 q_e q_m}{4\pi} \hat{\mathbf{x}}$$
$$\Rightarrow q_e q_m = n \frac{h}{\mu_0} \quad (n \text{ integer number})$$

Explains quantisation of electric charge!

- Fundamental magnetic charge (with $q_m = g_e c$ and $n = 1$)

$$g_D = h/(\mu_0 e^2 c) = 68.5$$

- Ionisation at high velocities $\propto g^2$
→ >4500 times more than a proton!

't HOOFT AND POLYAKOV's GUT MONOPOLES

Nucl. Phys. B79, 276 (1974)



Assume the U(1) group of electromagnetism is a subgroup of a broken gauge symmetry

- Monopoles arise as solutions of the field equations.
Very general result!
- Monopole mass \sim unification scale

**LHC
reach**

GUT monopole

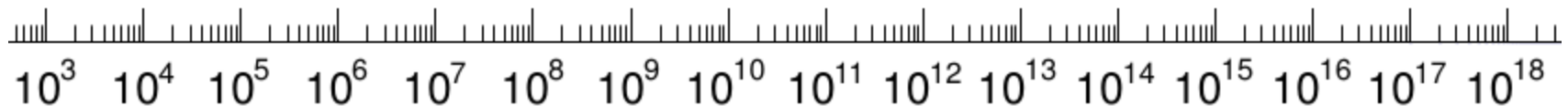

Possible monopole mass range (GeV)

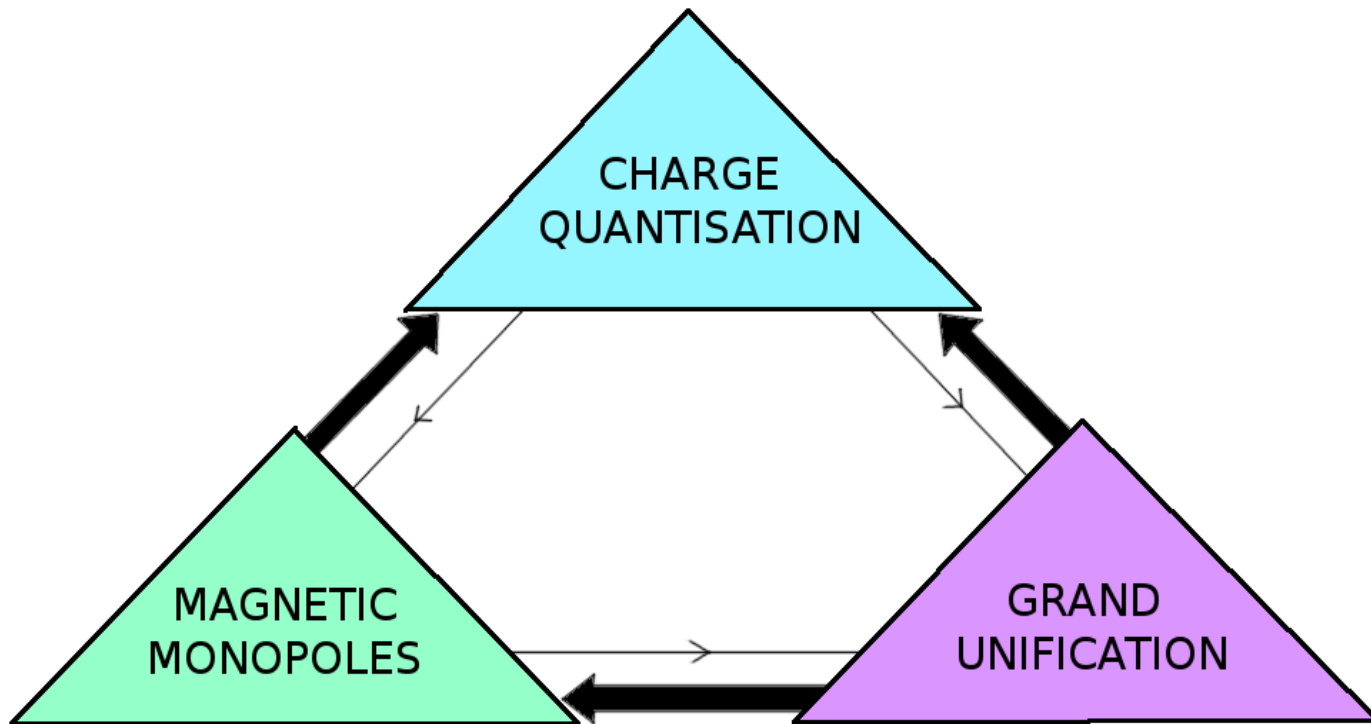

No sign of them up to mass ~ 1 TeV so far.

→ Explore higher masses

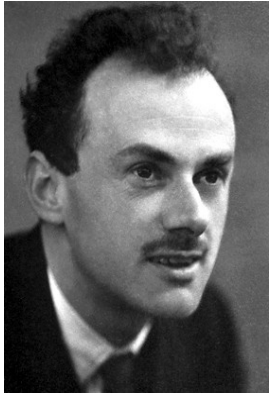

Bevatron

IHEP

ISR

CESR

SLAC

LEP

Tevatron

AGS

Fermilab

PETRA

TRISTAN

HERA

LHC

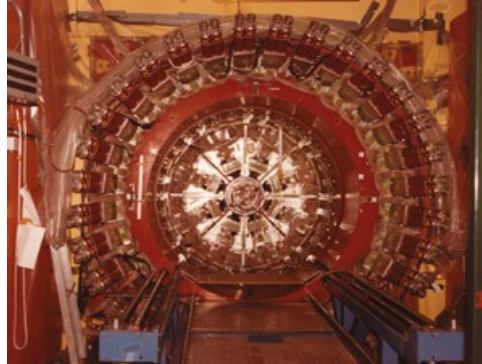
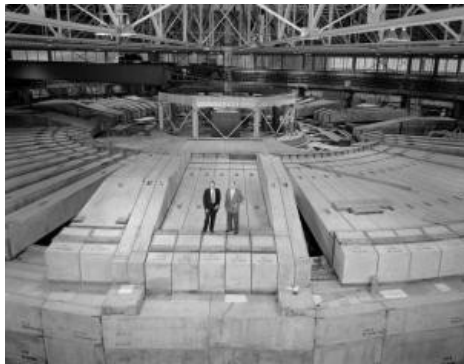

COLLIDER SEARCH TECHNIQUES FOR DIRECT DETECTION

- General-purpose detectors
- Nuclear-track detectors
- Trapping experiments – induction technique

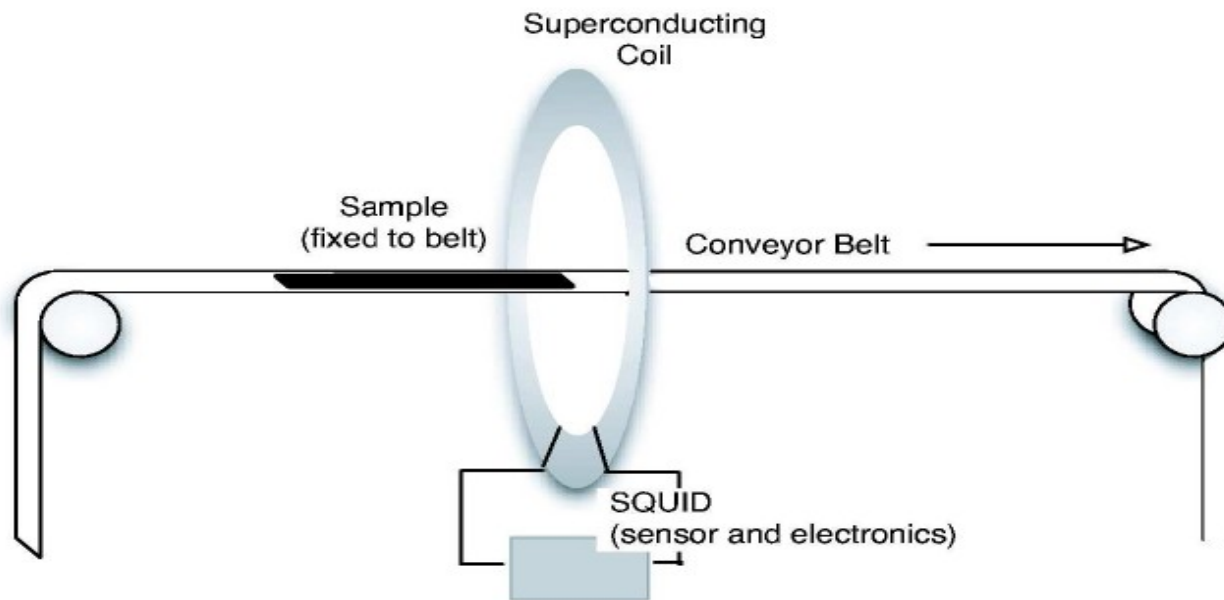
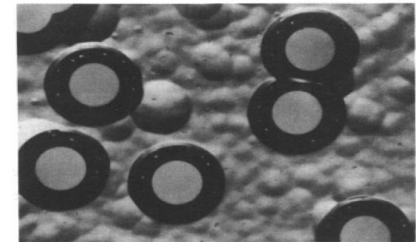
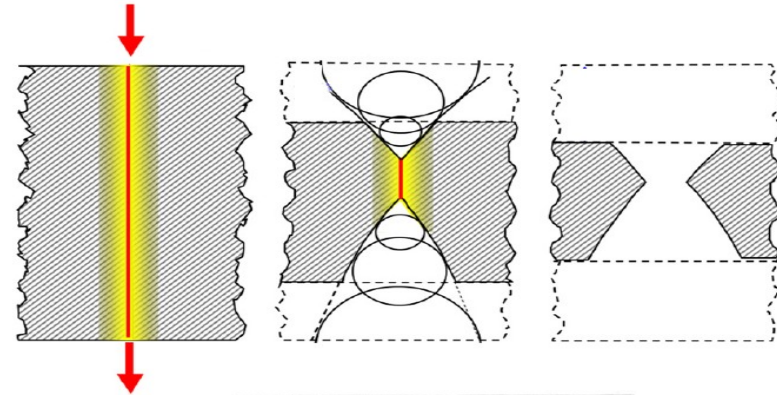

DIRECT COLLIDER SEARCHES – CURRENT LIMITS

Phys. Rept. 438, 1 (2007), arXiv:hep-ph/0611040

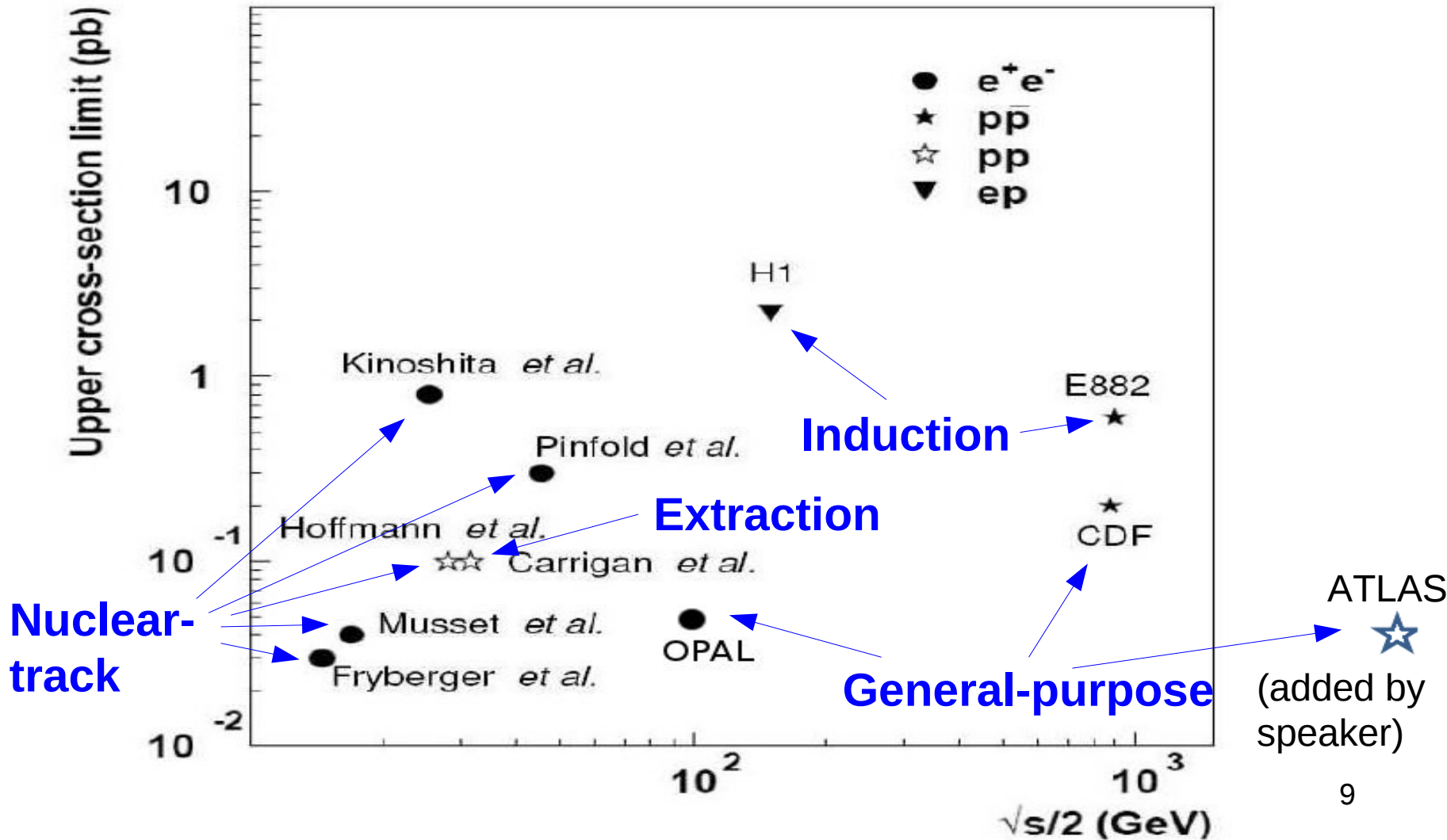

ATLAS SEARCH

First monopole constraints at the LHC

- 2 fb⁻¹ of 7 TeV pp collision data
- Cross section limits *for $g = g_D$* and $200 < M < 1500$ GeV

PRL 109, 261803 (2012), arXiv:1207.6411

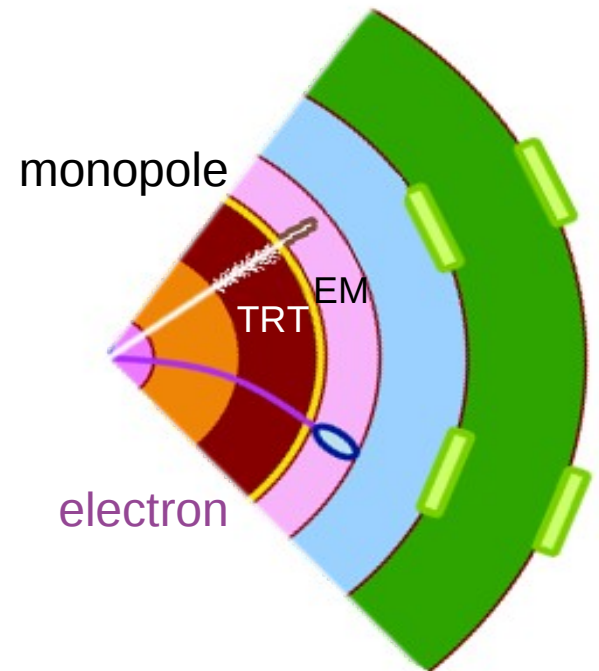
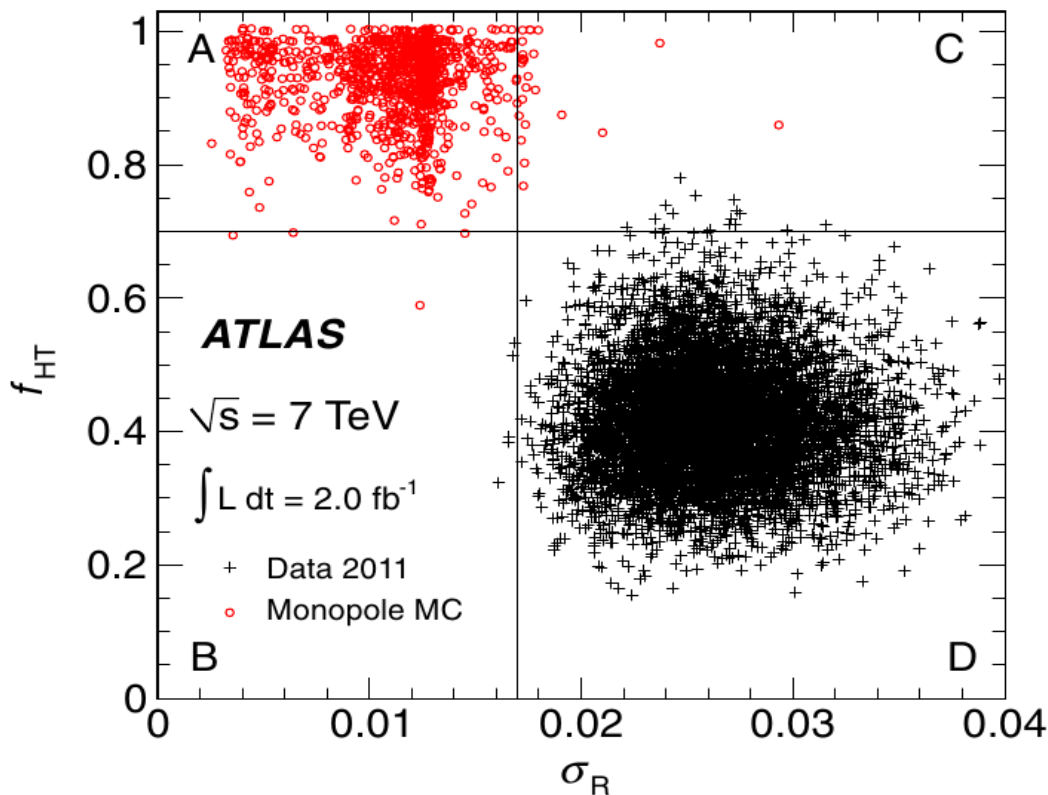

NEW ATLAS HIP SEARCHES

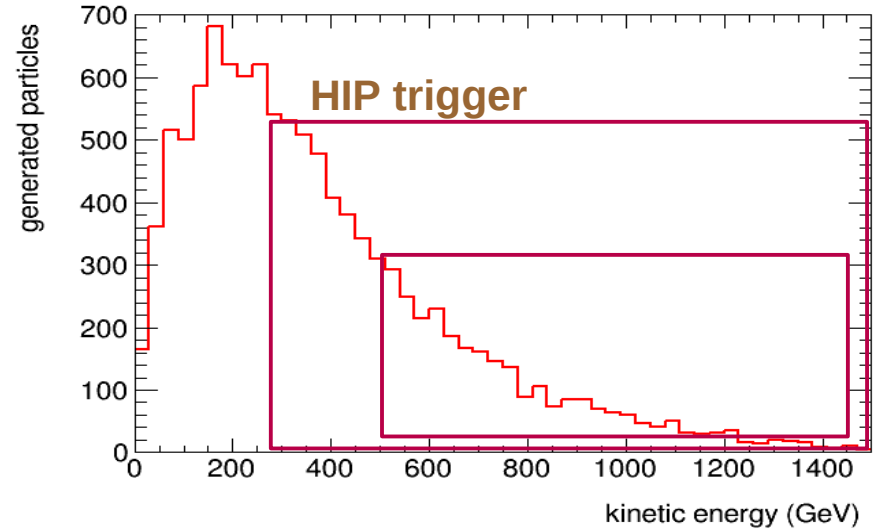
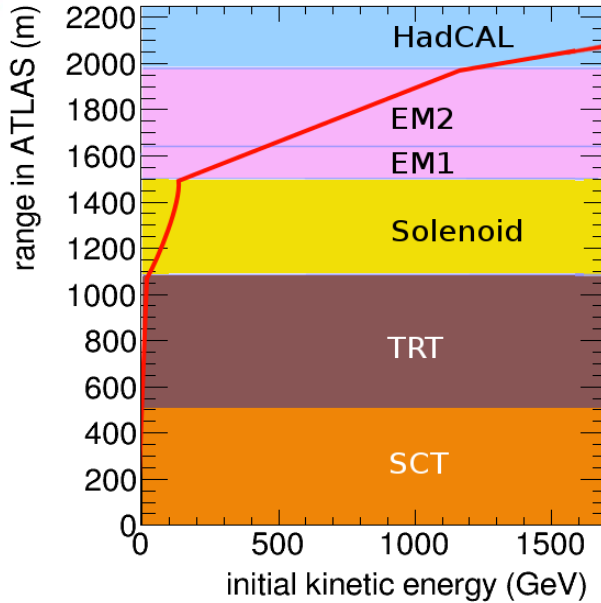
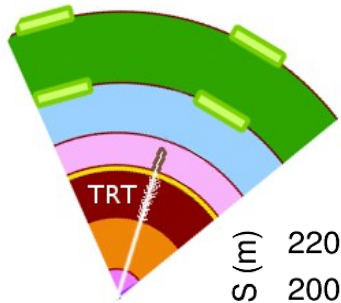

HIP trigger

- 7 fb⁻¹ of 8 TeV data
- Preparations for 14 TeV collisions

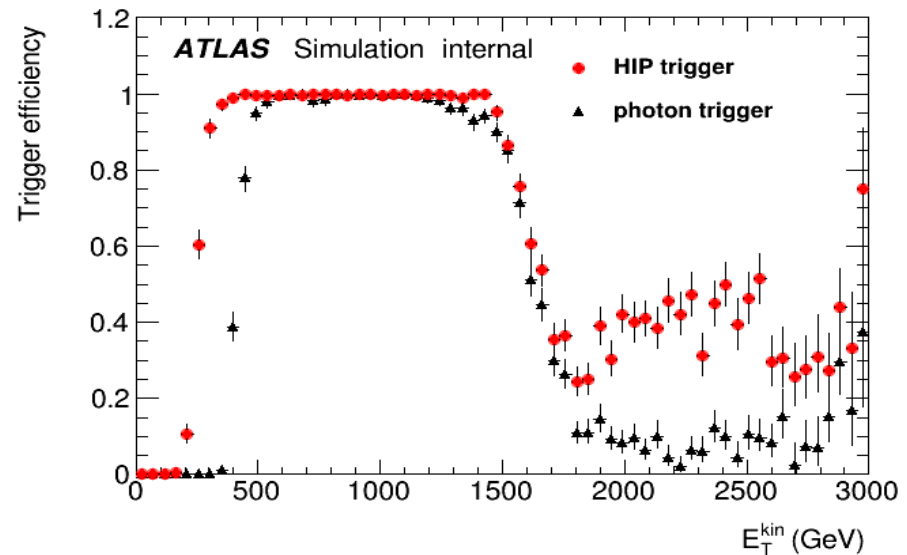

MoEDAL

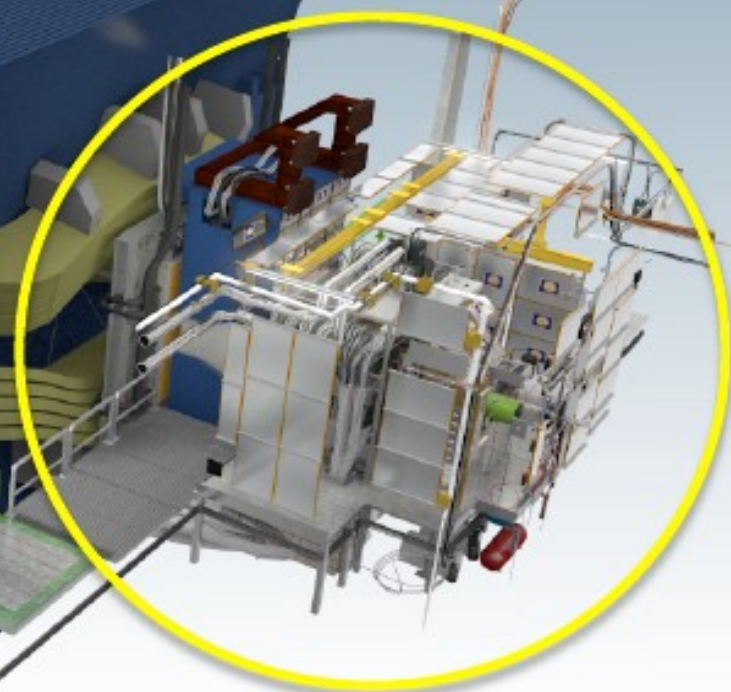
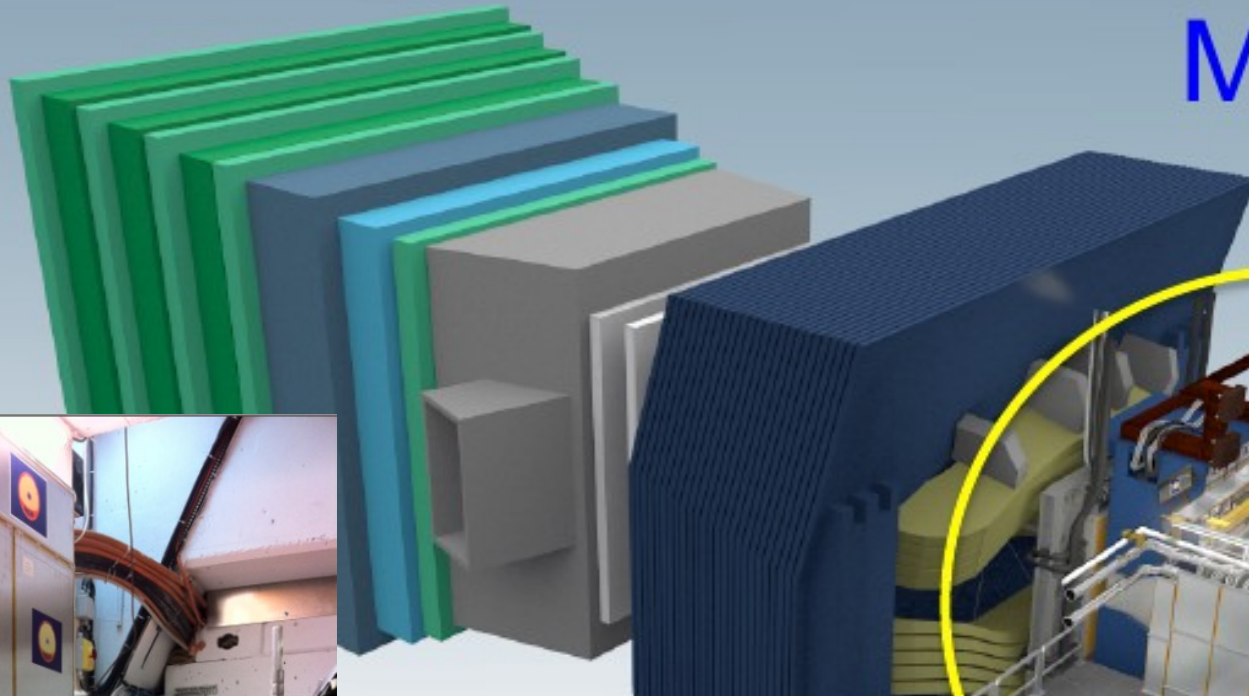

MAGNETIC MONOPOLE TRAPPER (MMT)

arXiv:1311.6940

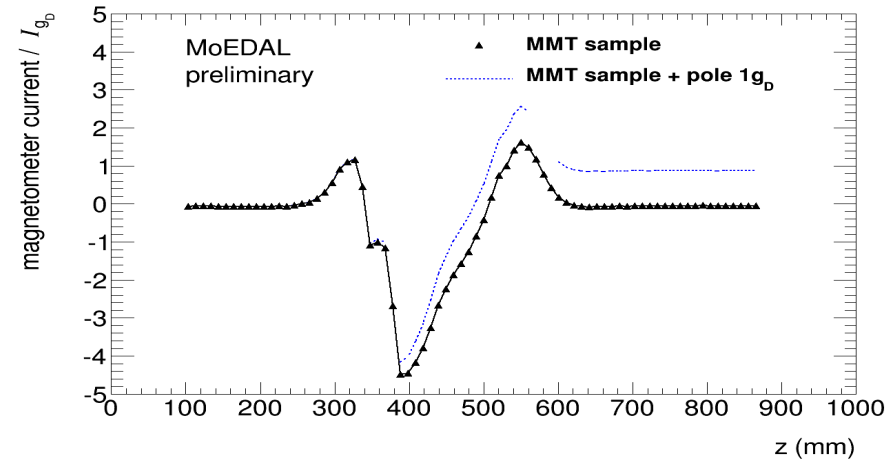
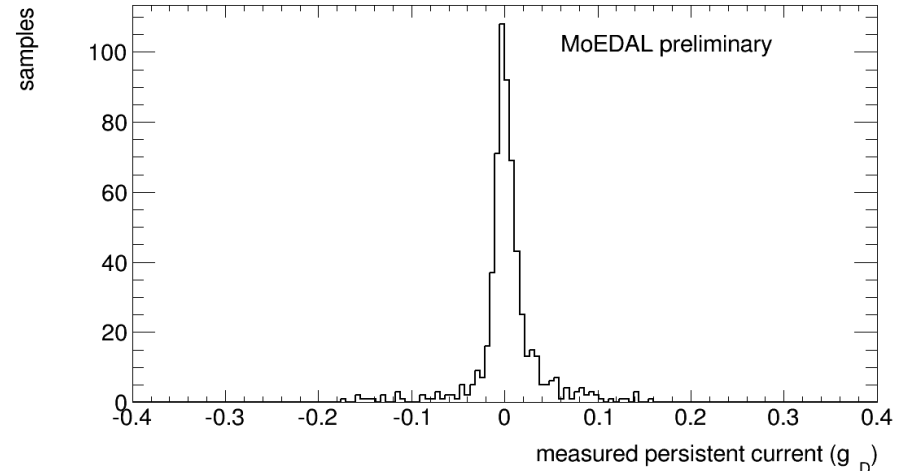
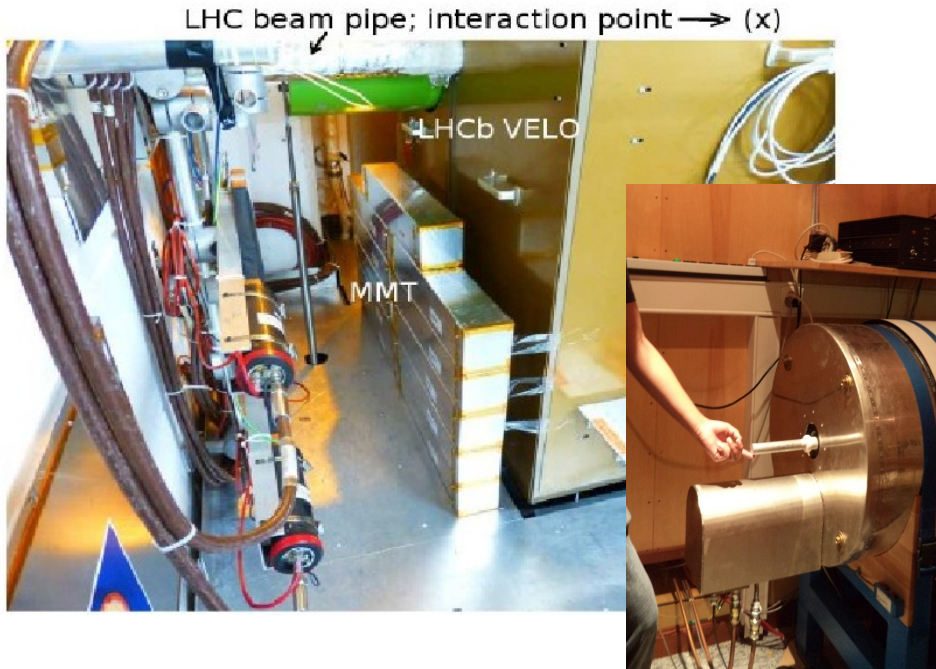

Aluminium test array

- Exposed to 8 TeV collisions
- Scanned with superconducting magnetometer in Zürich

First LHC constraints on multiply-charged monopoles

LHC BEAM PIPES

ATLAS and CMS beryllium pipes replaced after 8 TeV runs

- Available for analysis in 2017
- Cut and scan with magnetometer



Only way to detect very-high-charge monopoles

EPJC 72, 1985 (2012), [arXiv:1112.2999](https://arxiv.org/abs/1112.2999)

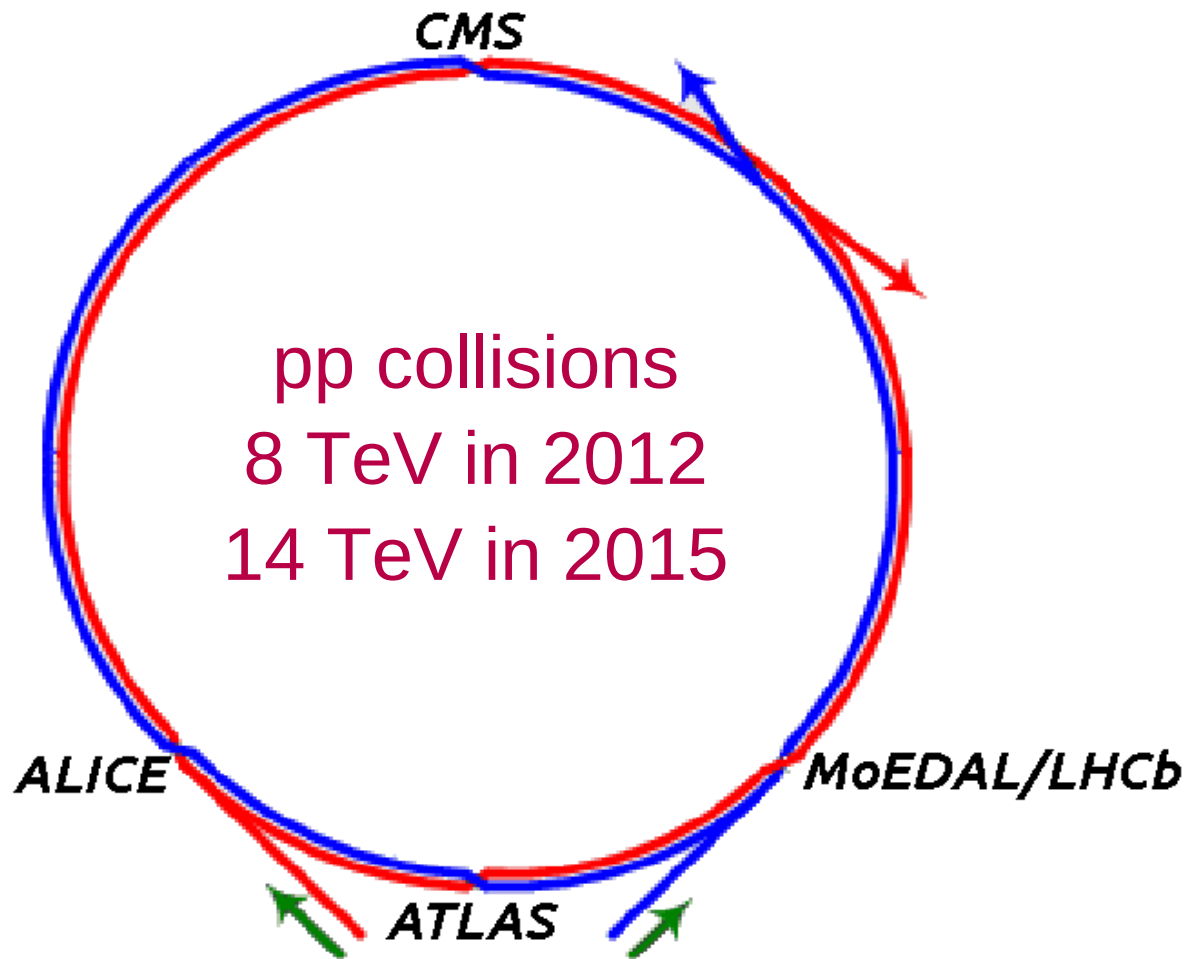

LHC 8 TeV COVERAGE

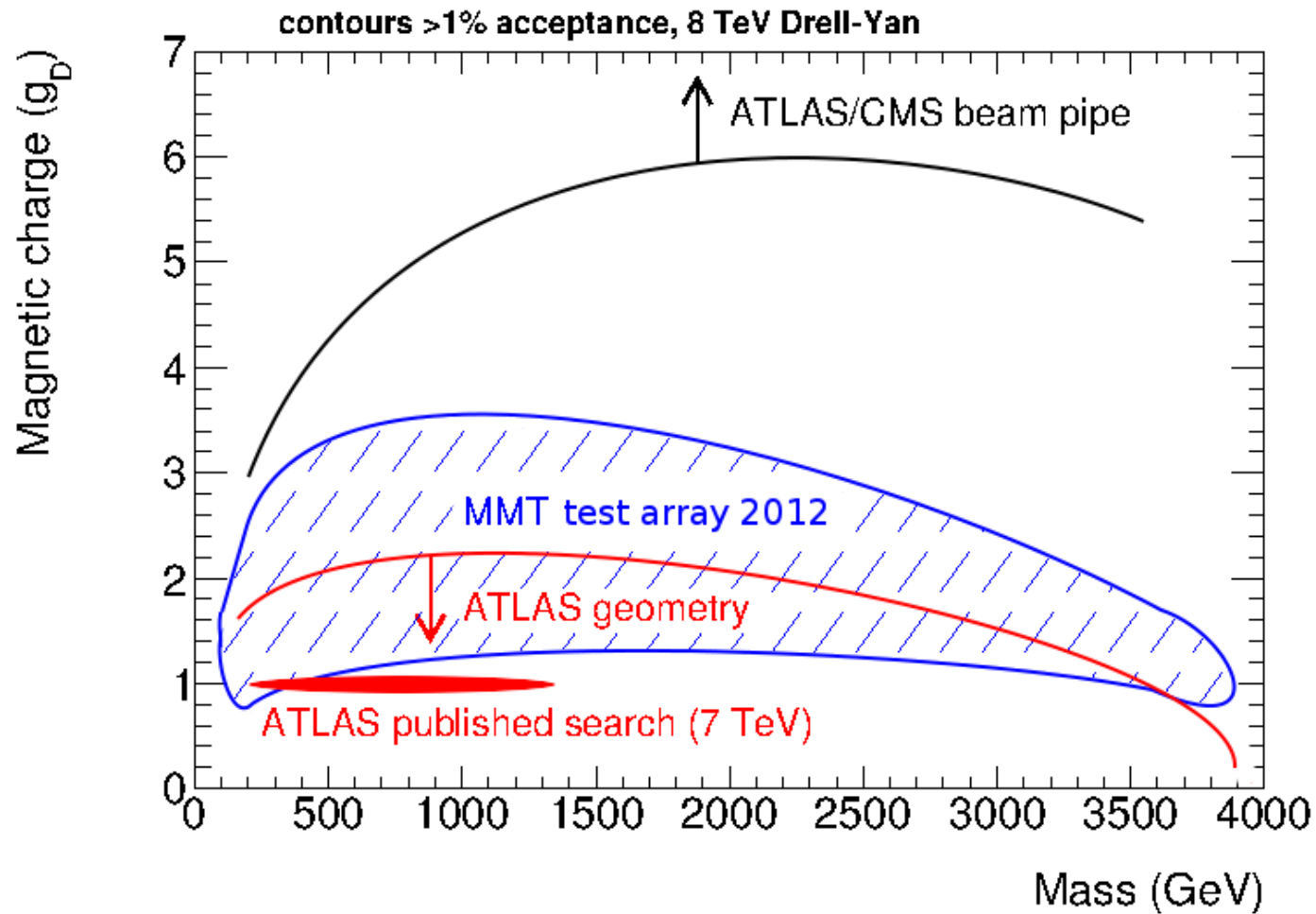

LHC 14 TeV PROSPECTS

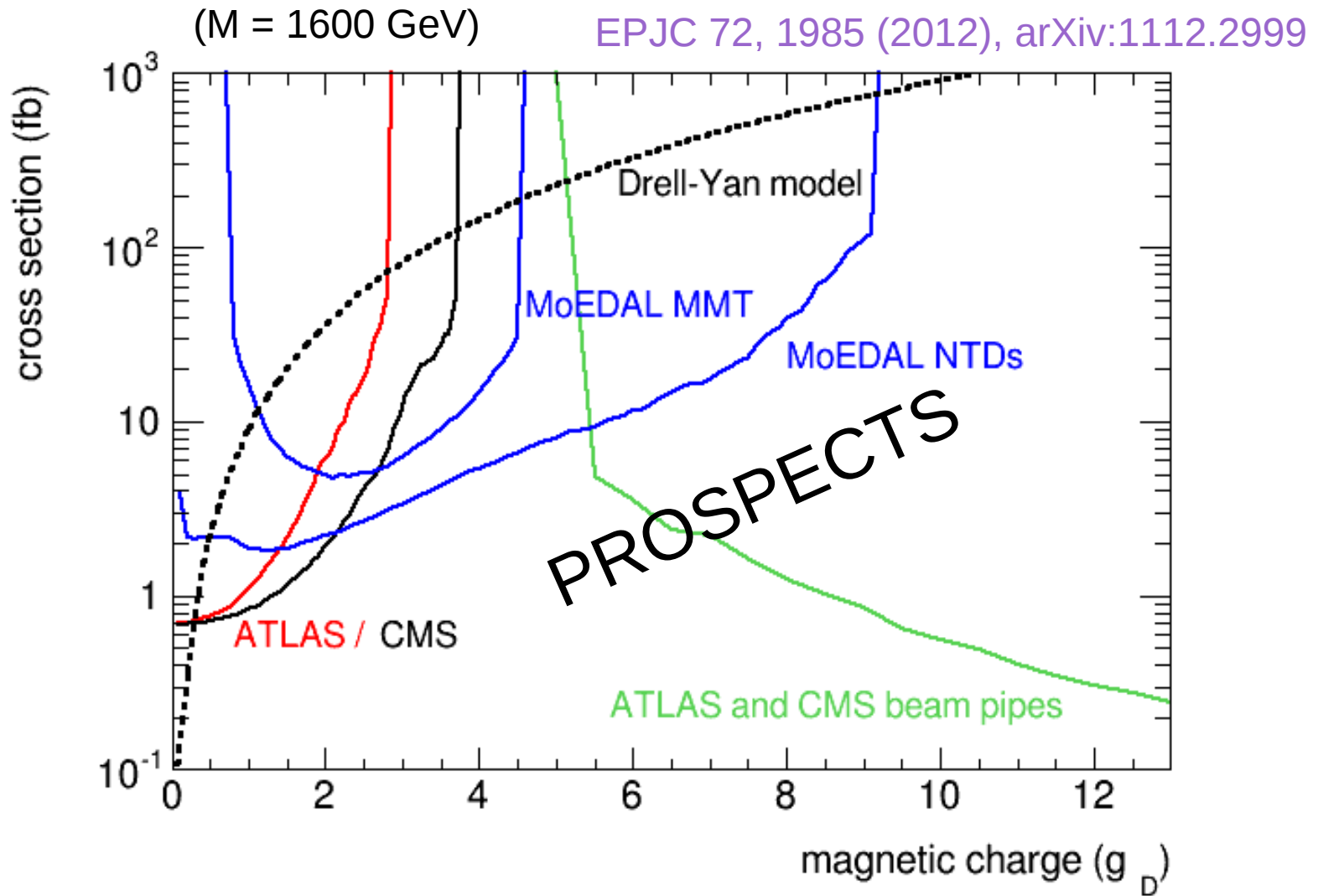

PRIMORDIAL MONOPOLES

Big Catastrophe:

Enormous GUT monopole density!

Inflation theory solves this problem by diluting the monopoles

Large uncertainty on relic monopole abundances

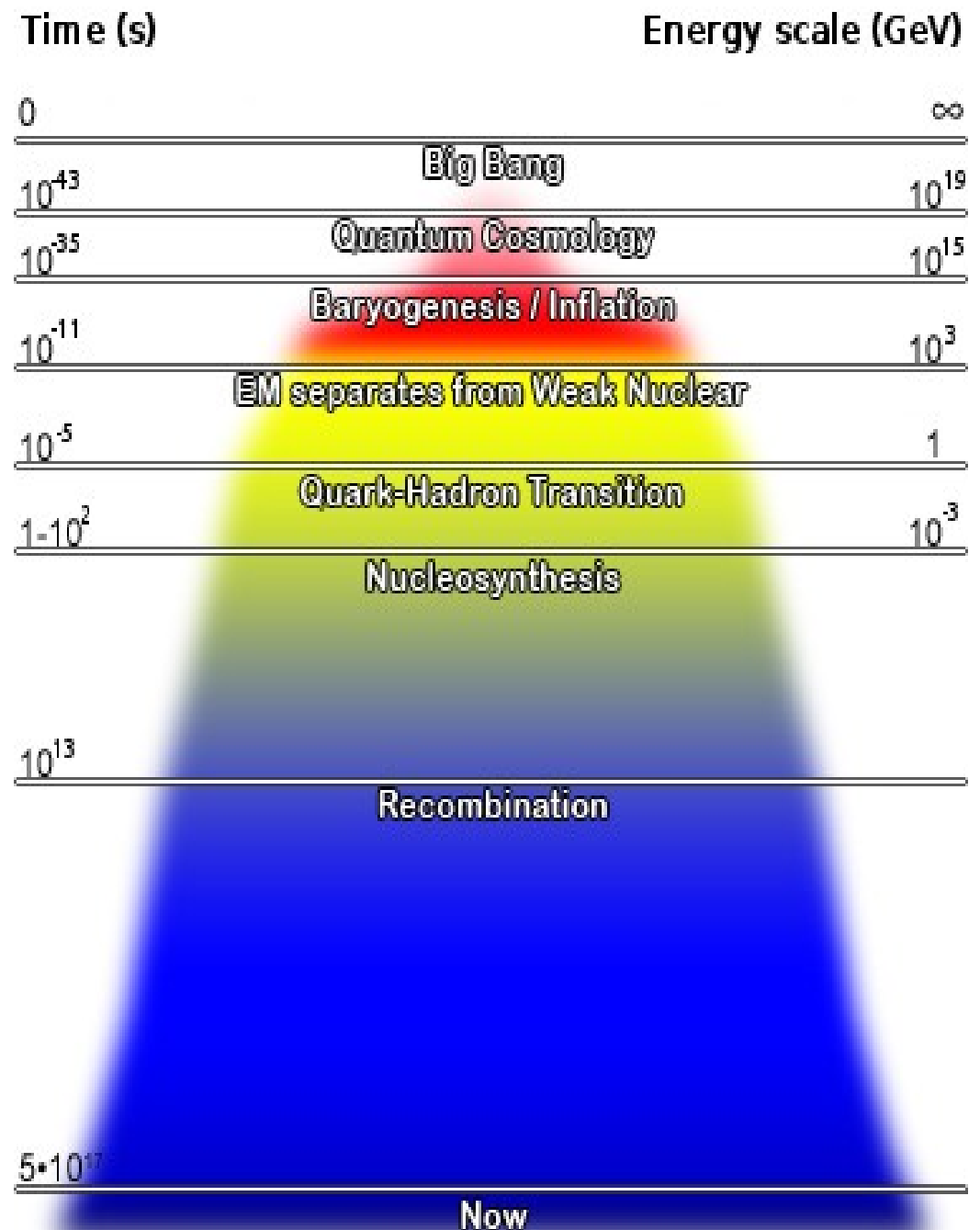



INDUCTION ARRAYS

- Response depends only on magnetic charge → can probe very low velocities / high masses
- Exposure ~ 1 year
- Cryogenics limit area to ~1 m²
- Spurious offsets can happen → need multiple loops
- $F < 2 \cdot 10^{-13} \text{ cm}^{-2} \text{ s}^{-1} \text{ sr}^{-1}$

PRL 64, 835 (1990)

PRL 64, 839 (1990)

PRD 44, 622 (1991)

PRD 44, 636 (1991)

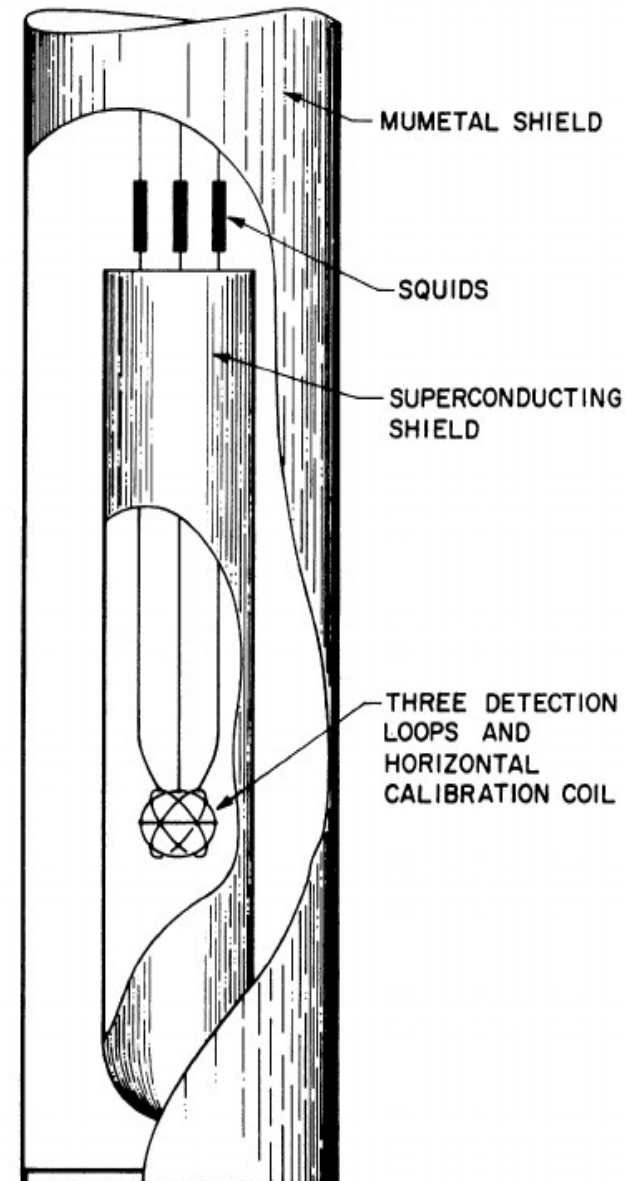

IONISATION ARRAYS – MACRO

- ~1400 m underground
- 1000 m², 10 m height
- Exposure: 5 years
- **Various detection techniques:**
 - Scintillator (time-of-flight):
 $0.0001 < \beta < 0.01$
 - Scintillator (dE/dx):
 $0.001 < \beta < 0.1$
 - Streamer tubes:
 $0.001 < \beta < 1$
 - Nuclear-track:
 $0.001 < \beta < 1$
- $F < 10^{-16} \text{ cm}^{-2}\text{s}^{-1}\text{sr}^{-1}$



SLIM

- Altitude: 5230 m
(Chacaltaya observatory)
- 400 m²
- Exposure: 4 years
- $F < 10^{-15} \text{ cm}^{-2}\text{s}^{-1}\text{sr}^{-1}$



EPJC 55, 57 (2008), arXiv:0801.4913

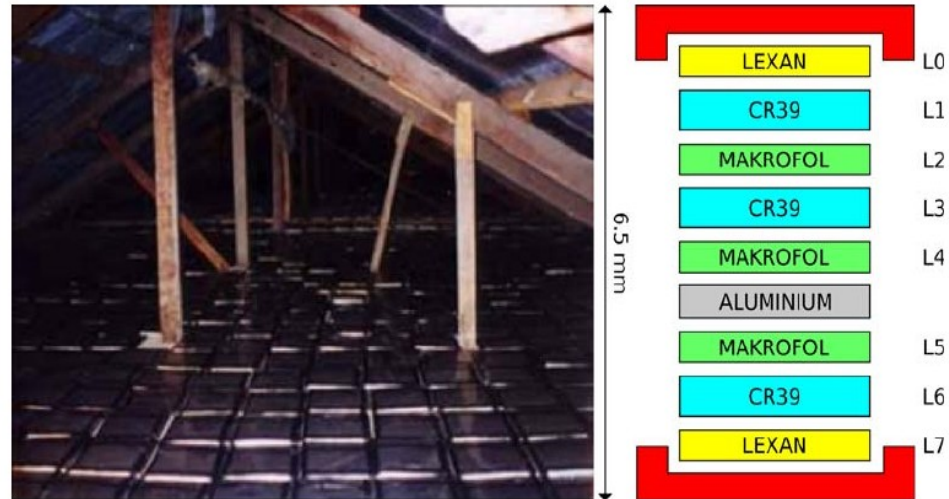
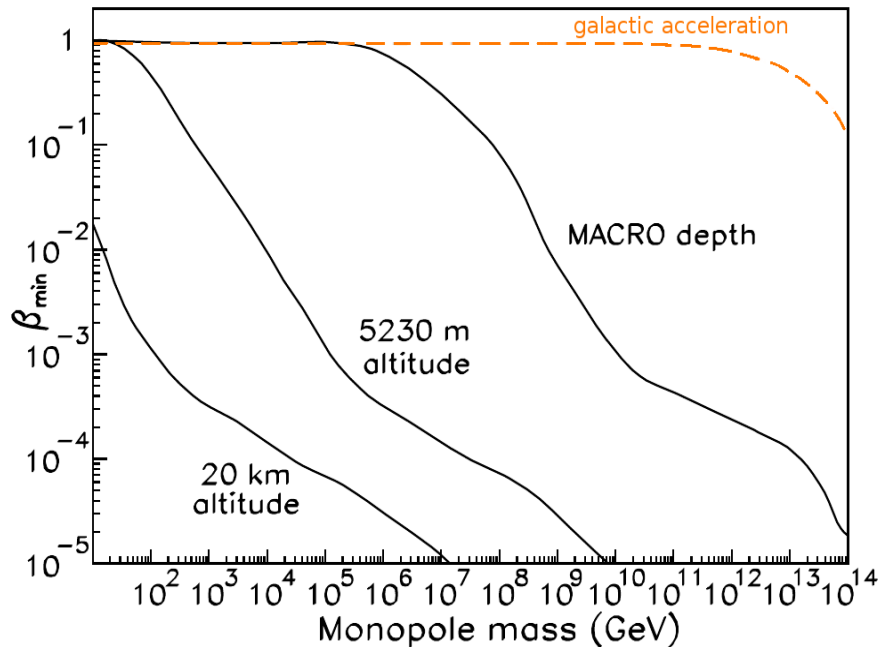

NEUTRINO OBSERVATORIES

Upgoing monopole
(must traverse Earth)

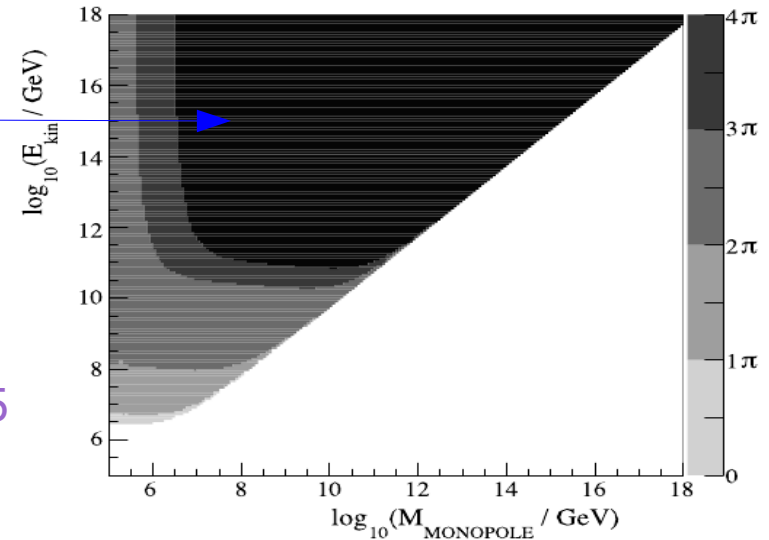

PRD 78, 075031 (2008), arXiv:0806.2129
 PRD 83, 023513 (2011), arXiv:1008.1282
 Astropart. Phys. 35, 634 (2012), arXiv:1110.265
 PRD 87, 022001 (2013), arXiv:1208.4861

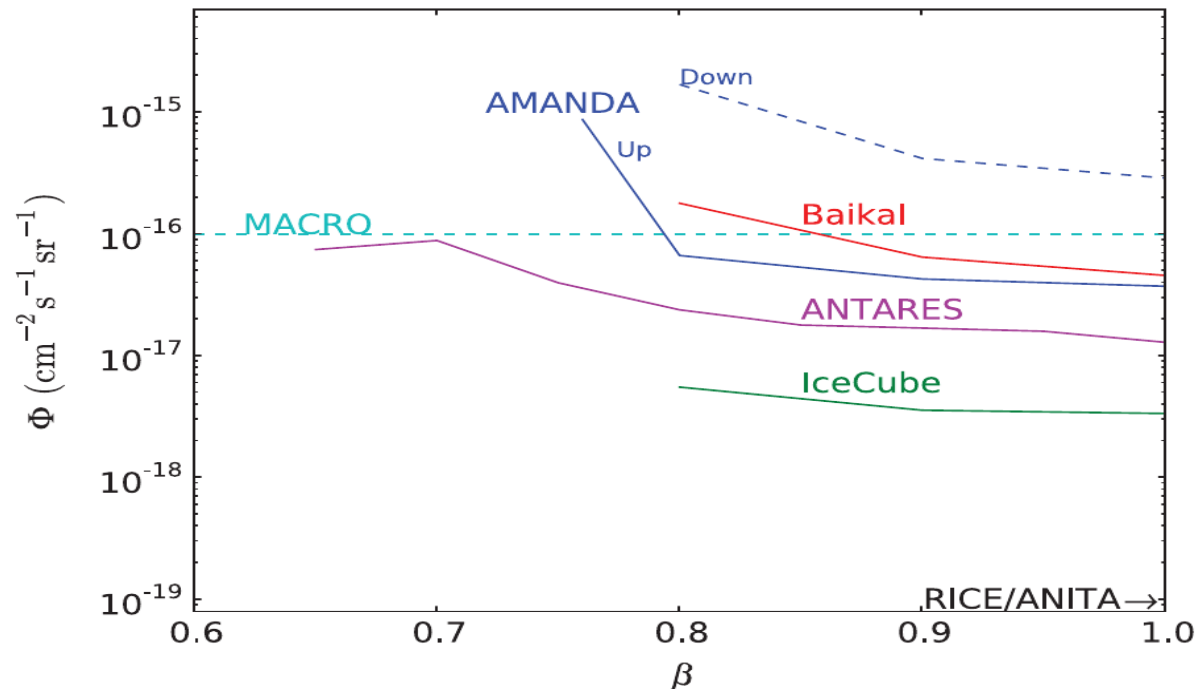
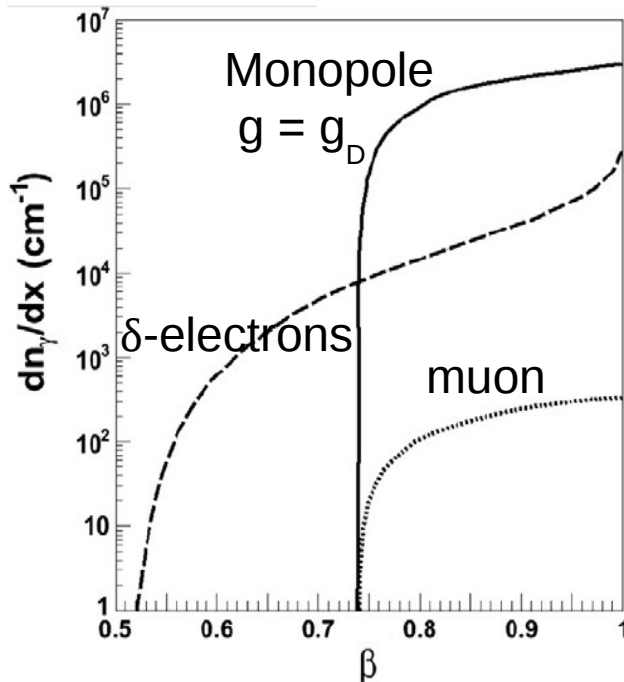

ANCIENT MICA

> 500 millions years exposure time!

Track formed only if:

- $g \geq 2 g_D$ (perhaps relativistic $g = g_D$)
- Or, low-velocity ($\beta \sim 10^{-3}$) monopole captured a nucleus on its way through the rock

Under one of the above assumptions

$$F < 5 \cdot 10^{-20} \text{ cm}^{-2} \text{ s}^{-1} \text{ sr}^{-1}$$

PR 184, 1398 (1969)

PRL 52, 1265 (1984)

PRL 56, 1226 (1986)

Europhys. Lett. 12, 25 (1990)

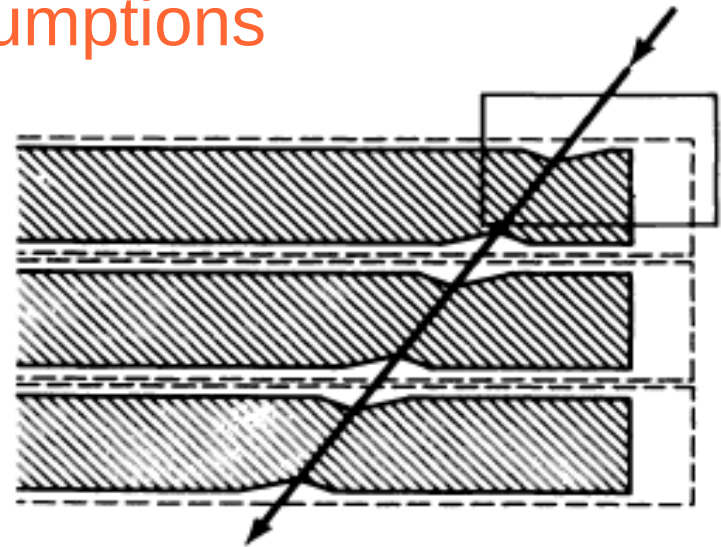

MATTER SEARCHES

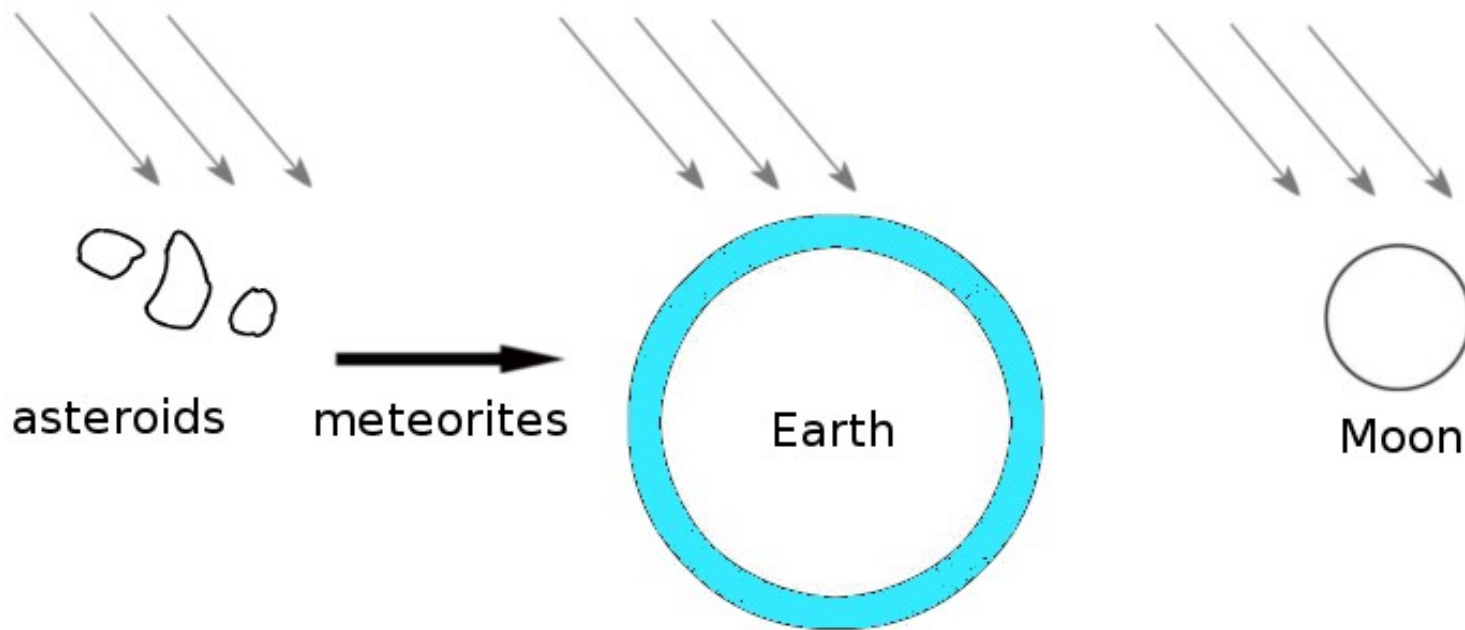

COLLECTION FROM ATMOSPHERE

50000 m² coverage

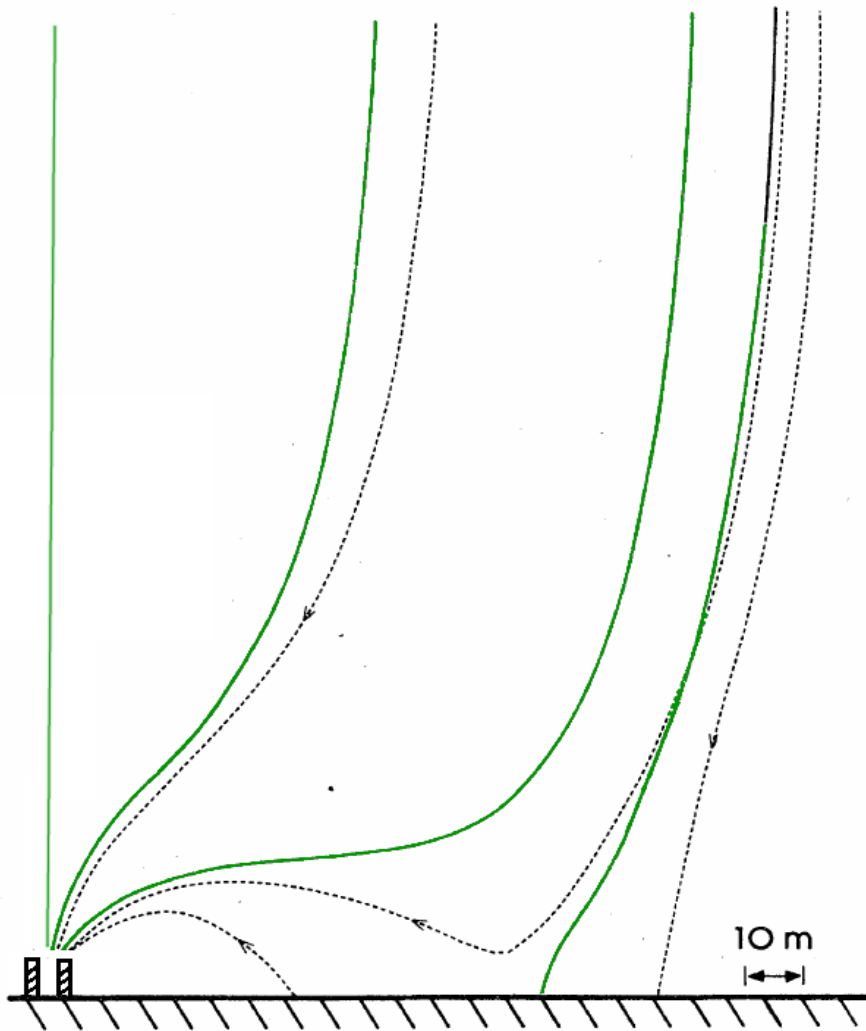

PR 83, 899 (1951)
PR 149, 1070 (1966)
PRD 24, 612 (1981)

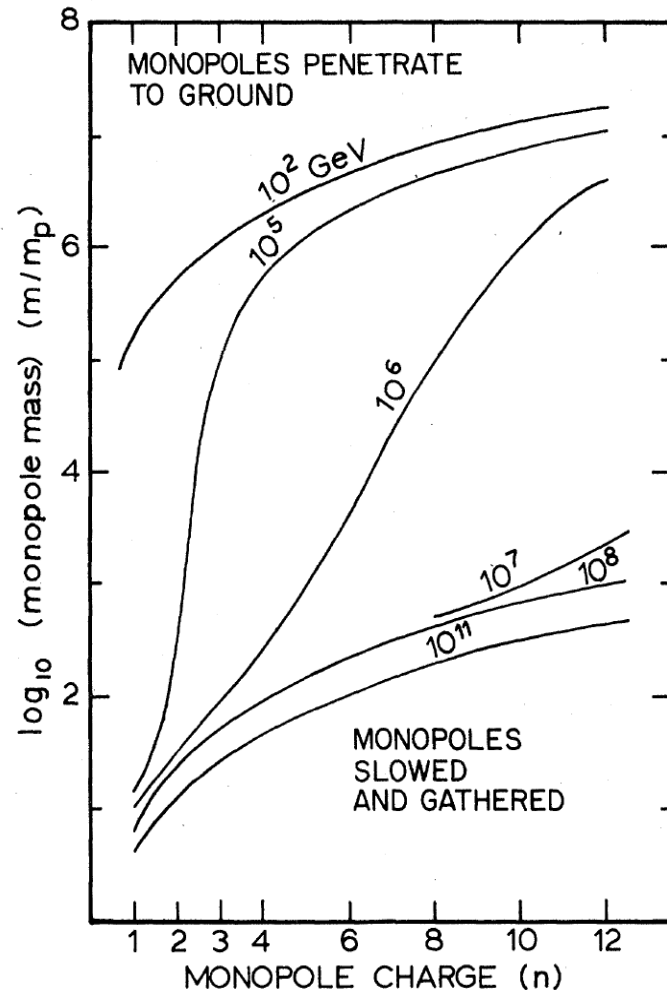

EXTRACTION TECHNIQUE

- Meteorite fragment Nucl. Phys. 49, 87 (1963)
- Magnetite and meteorite Phys. Rev. 132, 387 (1963)
- Deep-sea manganese nodules Phys. Rev. 177, 2029 (1969)
- Deep-sea sediments Phys. Rev. D 4, 1285 (1971)
- Air and sea water Phys. Rev. D 13, 1823 (1976)

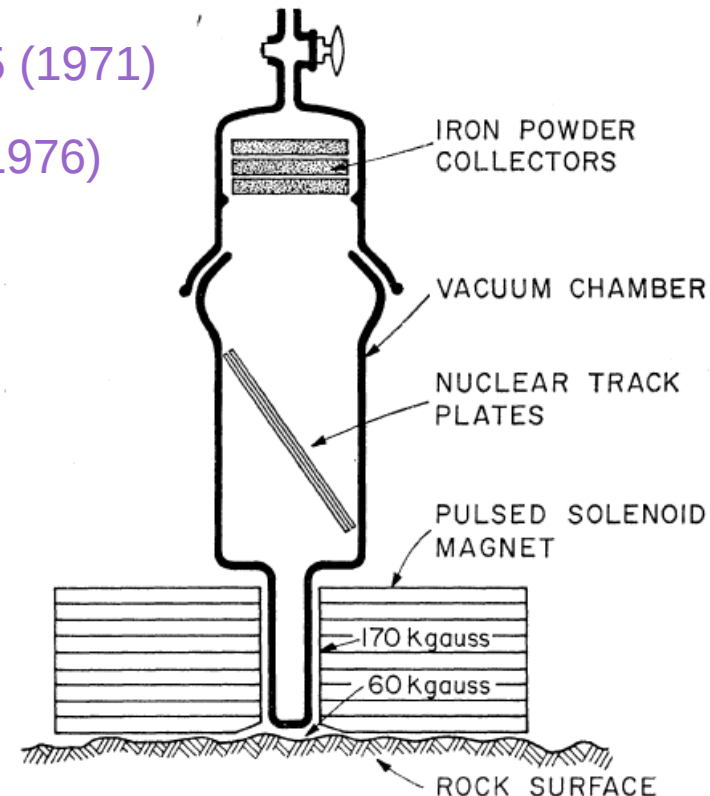
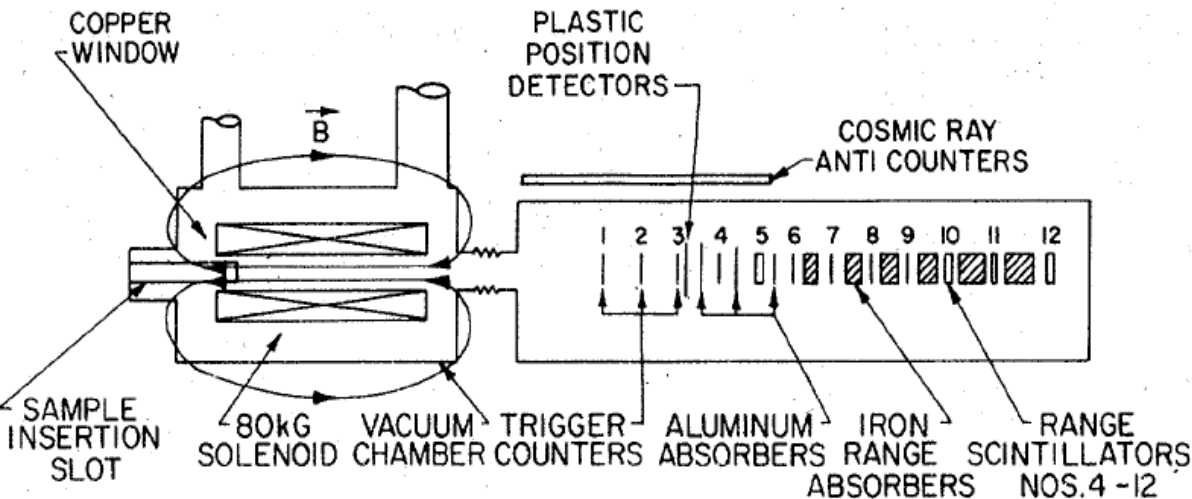

LARGE-SCALE INDUCTION SEARCH

- 180 kg sea water
- 145 kg manganese nodules
- 498 kg deep schist at 25 km depth
- 20 times more material than all previous searches together
- Robust technique

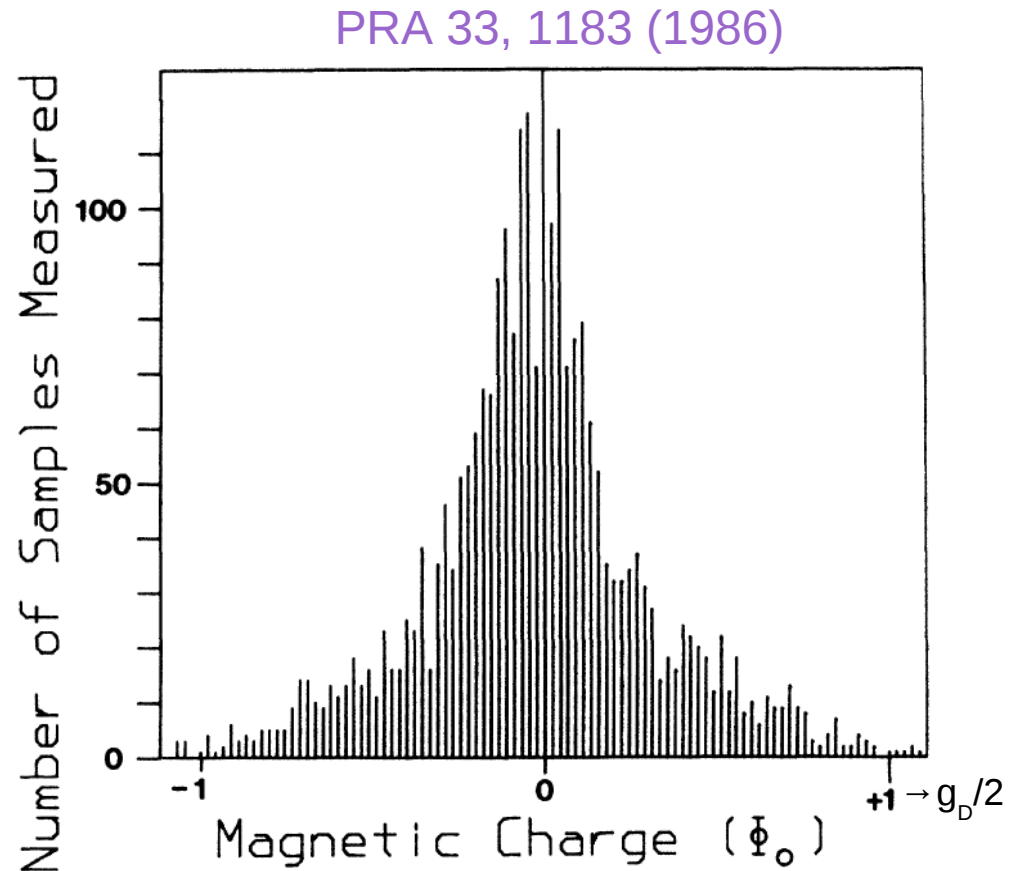

MOON ROCKS

- 48 kg returned from Apollo missions
- 4 billions years exposure
- No atmosphere and no magnetic field → robust assessment of monopole fate after stopping (few meters depth)



PRD 4, 3260 (1971)
PRD 8, 698 (1973)

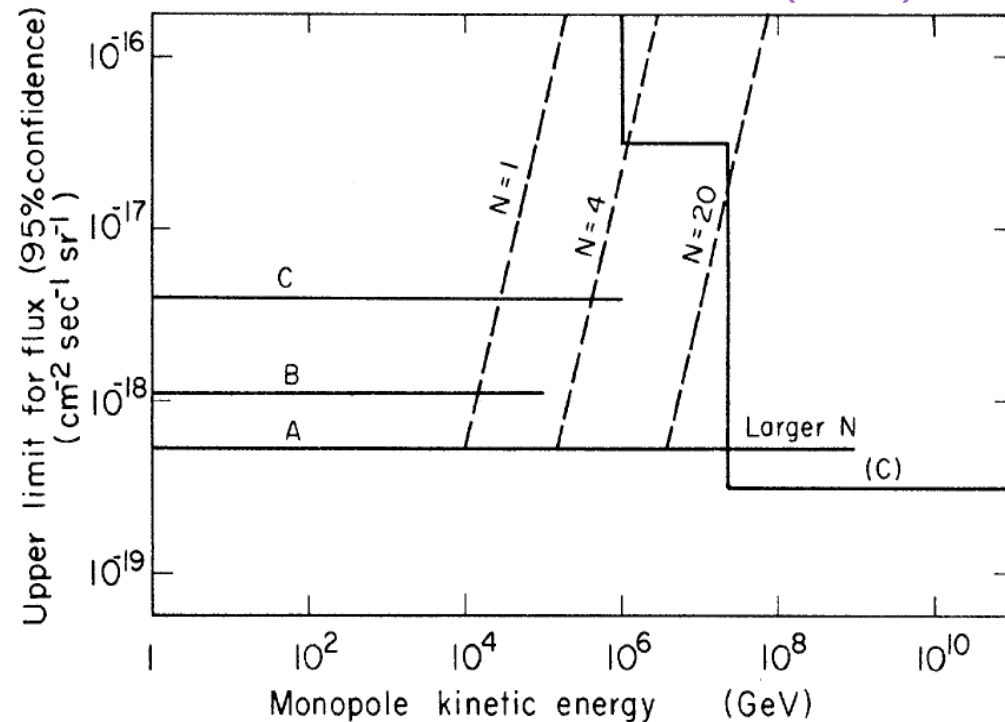
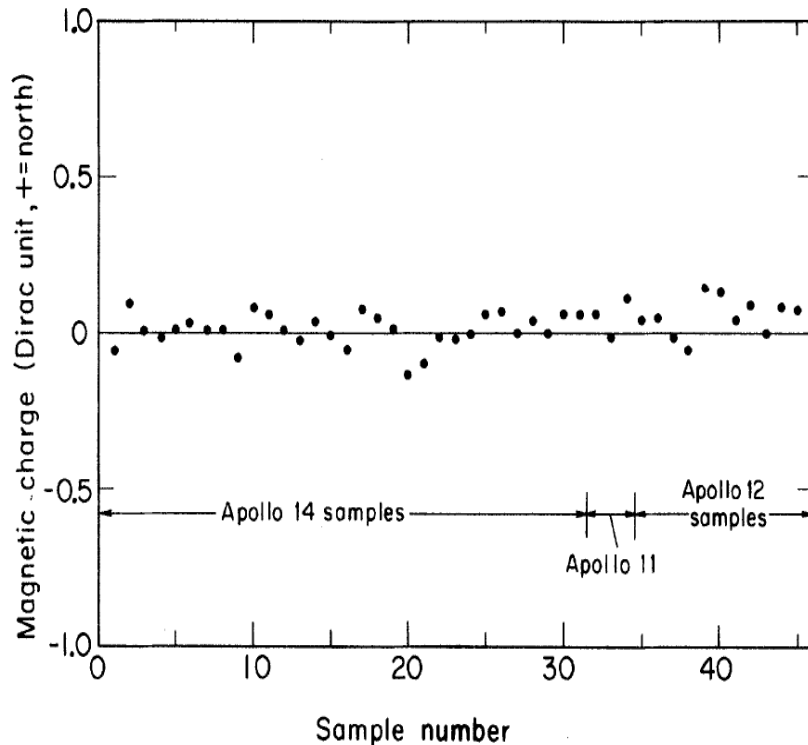

STELLAR MONOPOLES

Cloud

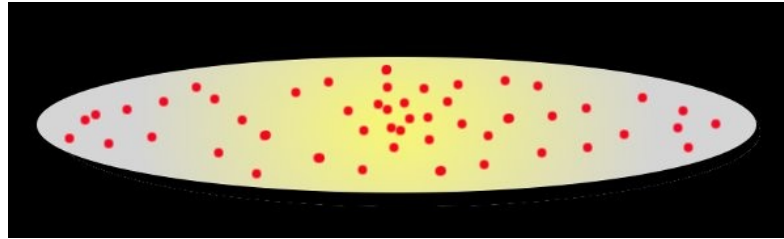

Planetary System

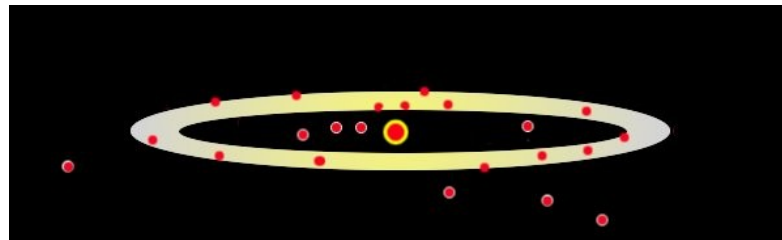

Heavier
than the
heaviest
nuclei →
absent from
crust

Planetary
differentiation

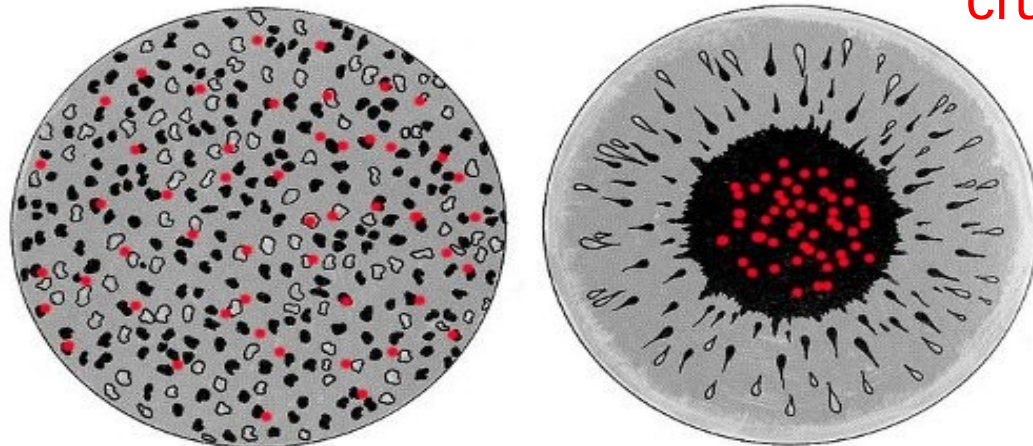

EARTH HEAT

Heat from monopole-antimonopole annihilations during geomagnetic reversals

→ limit $\rho < 10^{-4}$ mon./g [Nature 288, 348 \(1980\)](#)

Must assume mass $\sim 10^{16}$ GeV and:

- Stable dipole magnetic field when no reversal
- Monopoles and anti-monopoles both present

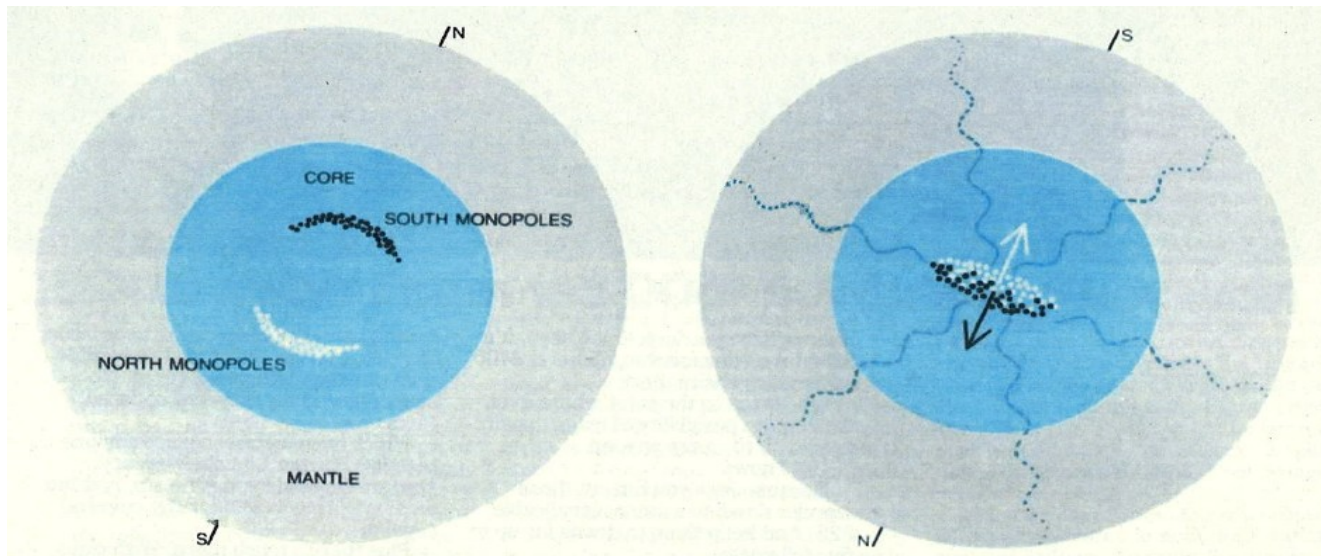

MOON FIELD

Magnetometer observations aboard Explorer 35 orbiting the Moon: No radial component

→ limit $\rho < 4 \cdot 10^{-9}$ mon./g PRD 27, 1525 (1983)

Must assume monopoles predominantly of one sign

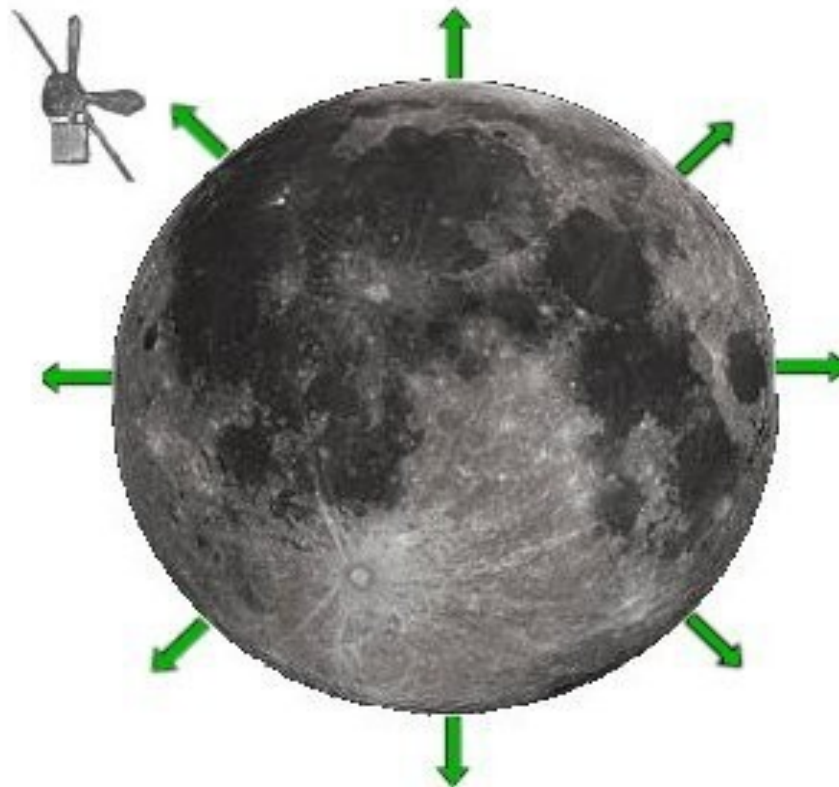

METEORITES



- **331 kg of rocks with induction technique**
(meteorites, ferromanganese nodules, iron ores, blueschists, sediments, kimberlites, chromates)
- **112 kg of meteorites** Phys. Rev. Lett. 75, 1443 (1995)
 - ~100 kg chondrites → **stellar monopoles!**
 - Masses up to 10^{17} GeV, beyond which monopoles might be dislodged by meteor impact

POLAR VOLCANIC ROCKS

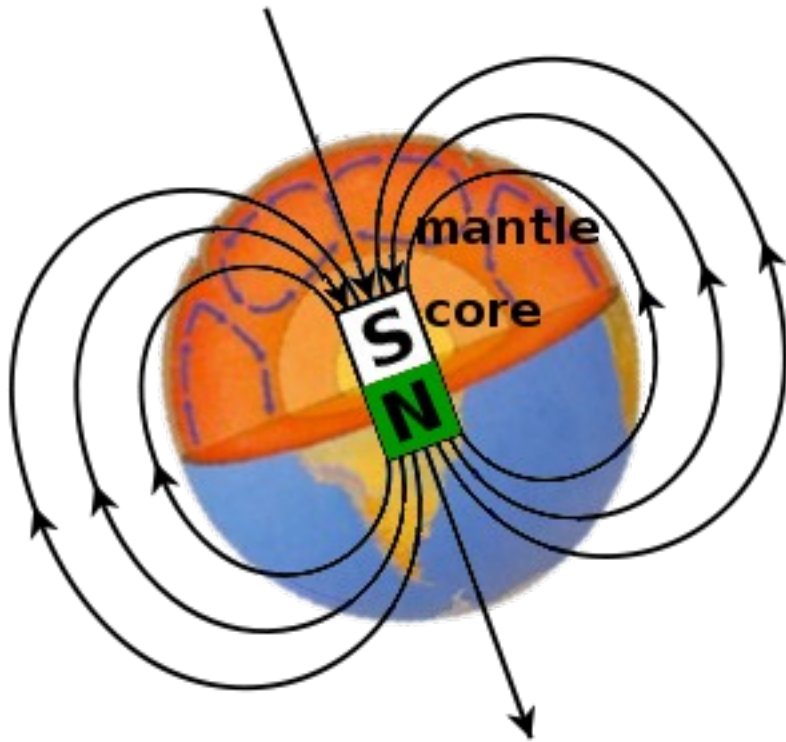

For Dirac charge ($n = 1$), magnetic force exceeds gravitational force above core-mantle boundary for:

$$M < 4 \cdot 10^{14} \text{ GeV}$$

Over geologic time, accumulation in the mantle beneath the geomagnetic poles

POLAR ROCKS – SAMPLES

High latitude ($>63^\circ$), mantle derived

- Hotspots
- Mid-ocean ridges
- Large igneous provinces
- Isotopic content indicating deep origins

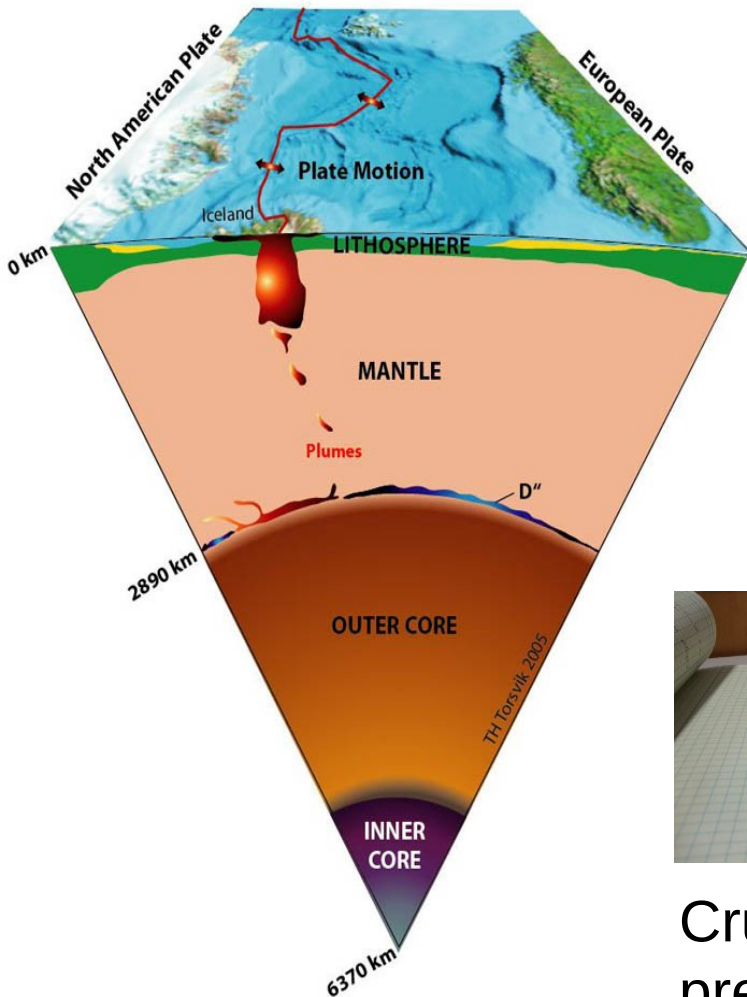

Crushed to reduce magnetisation for precise magnetometer measurement

POLAR ROCKS – RESULTS

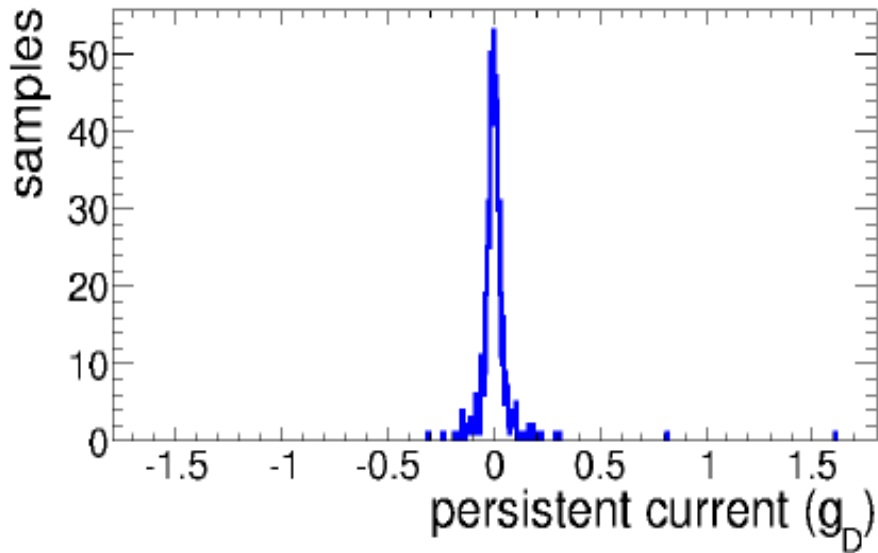

Phys. Rev. Lett. 110, 121803 (2013)

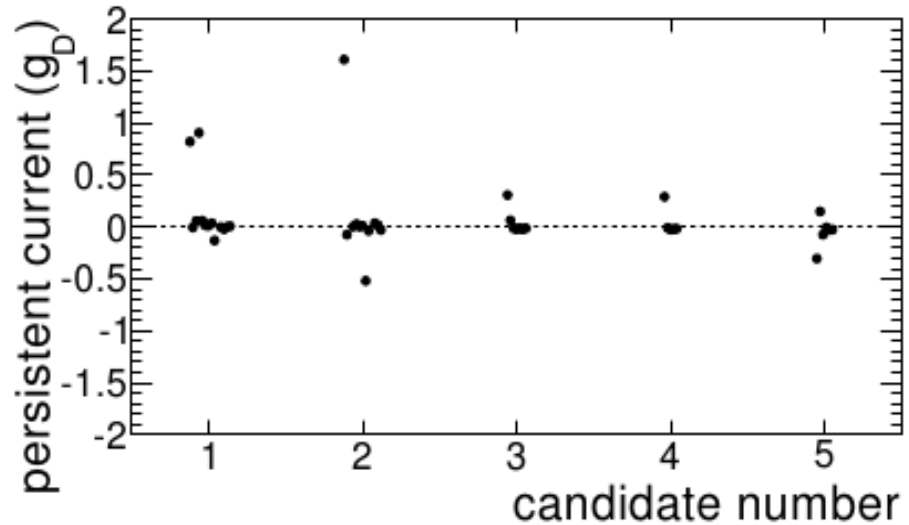

No monopoles found in 24 kg of polar volcanic rocks

- In simple model, translates into limit of less than 1.6 monopole per 100 kg in the Solar System

LIMITS ON STELLAR MONOPOLE DENSITY IN THE SOLAR SYSTEM

Earth heat
< 10^{-4} mon./g

Meteorites
< $2.3 \cdot 10^{-5}$ mon./g

Polar volcanic rocks
< $1.6 \cdot 10^{-5}$ mon./g

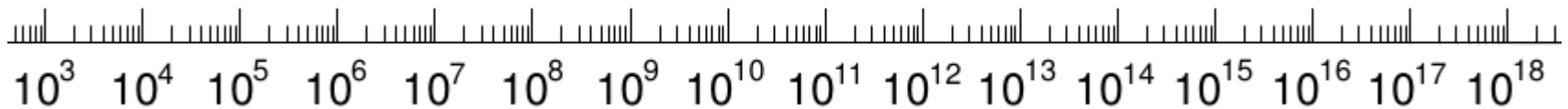

monopole mass (GeV)

COSMIC FLUX LIMITS – SUMMARY 1

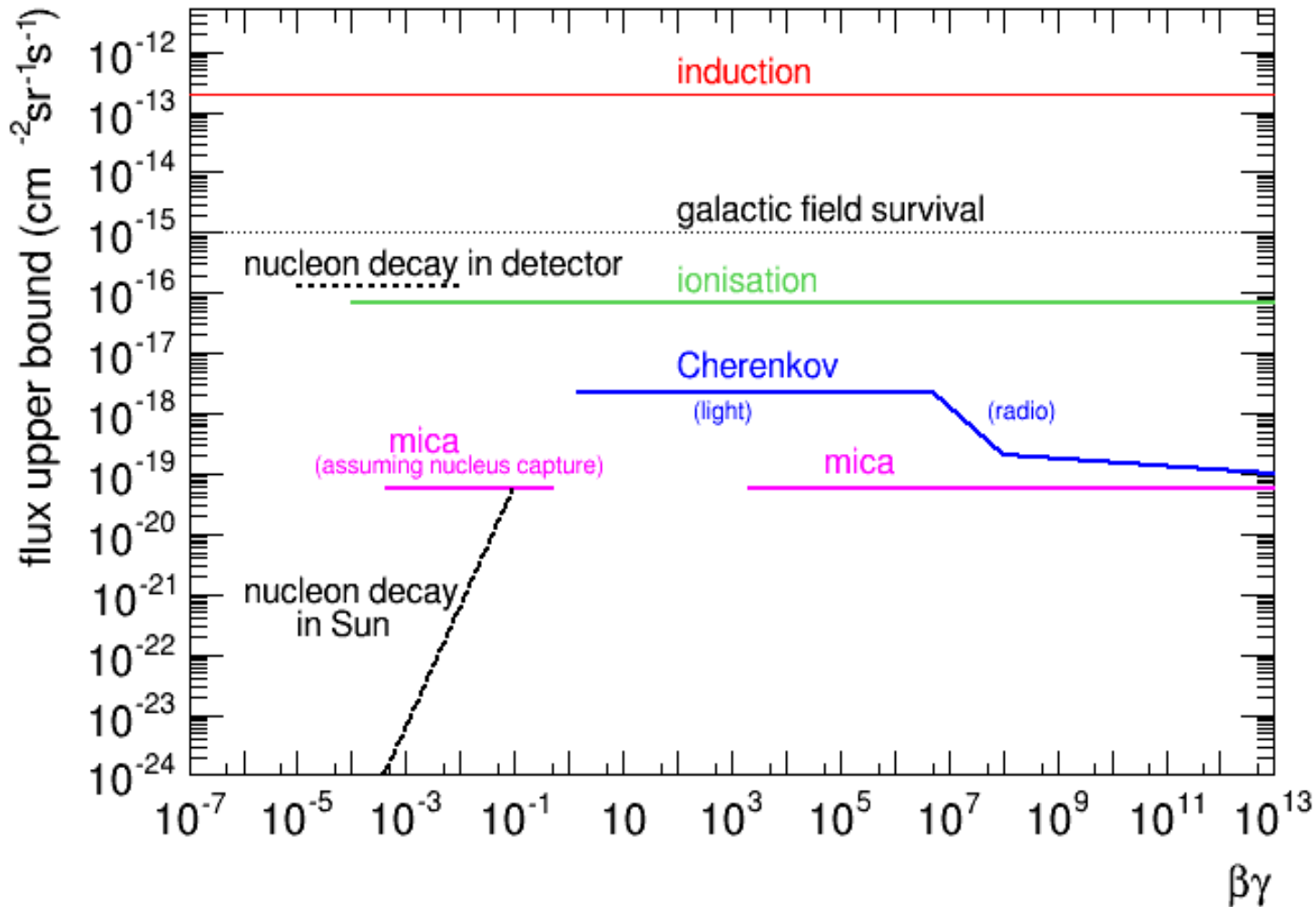

COSMIC FLUX LIMITS – SUMMARY 2

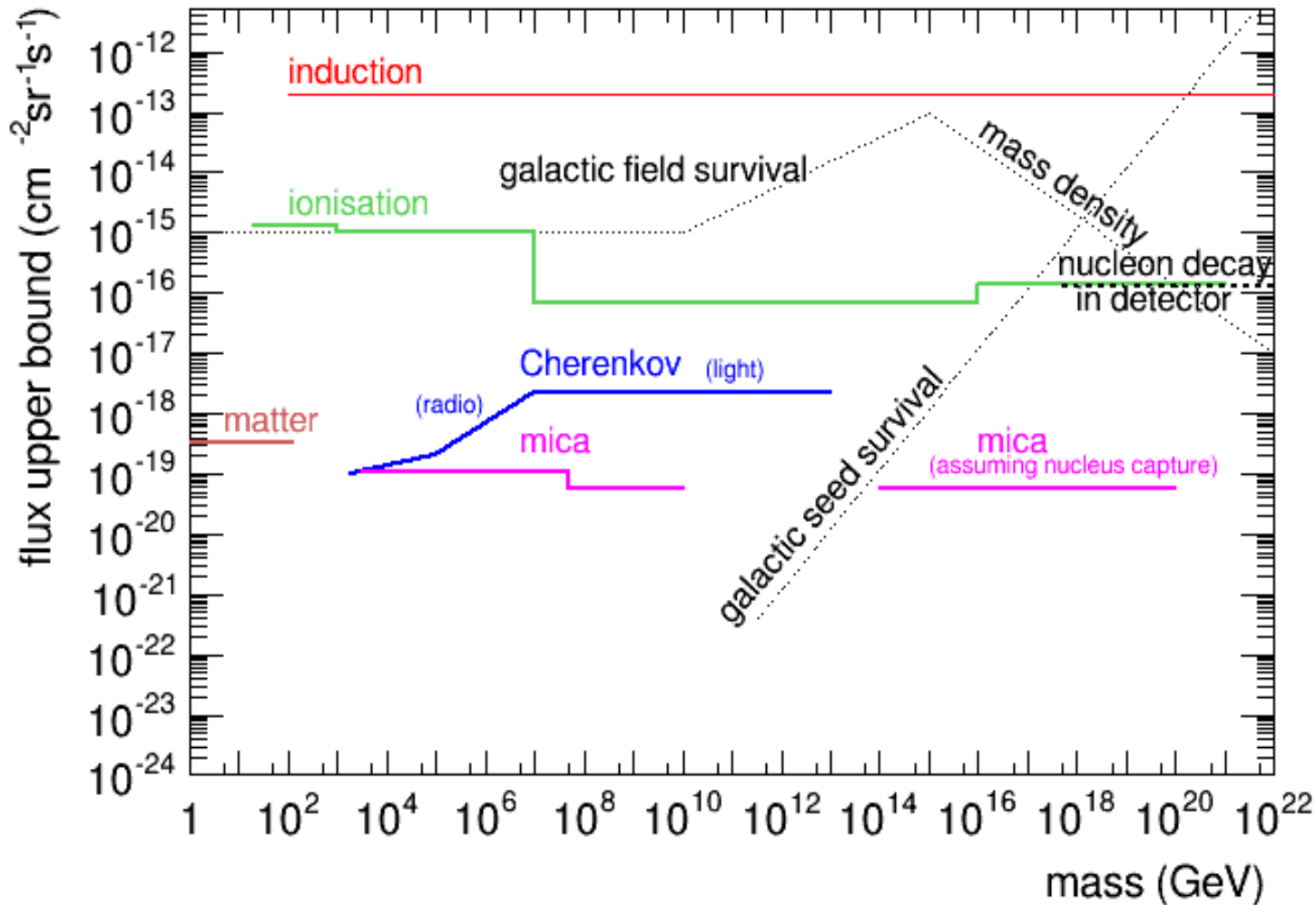

SUMMARY

Magnetic monopoles are fundamental, well-motivated objects

80 years after the Dirac argument, searches for monopoles are still very much alive

- In-flight detection with ATLAS / MoEDAL
- Trapping arrays / beam pipes
- Cosmic induction / ionisation / Cherenkov arrays
- Fossil tracks in mica
- Monopoles in sediments / rocks / meteorites

CAN WE DO BETTER?

Future Circular Colliders

- 10^{12} Z bosons → indirect effects $M < \sim 10$ TeV
- 100 TeV pp collider → direct searches $M < \sim 45$ TeV

Acoustic neutrino detectors

- 100 km³ → gain factor 20

Modern scanners with sub-micrometer precision at >100 cm² per hour

- 10 km² NTD array → gain factor 10
- 100 m² of ancient mica → gain factor 1000

Stellar monopoles

- 1 ton of polar rocks → gain factor 40
- Comet / asteroid fragments gathered in space missions

Extra slides

Schwinger's argument

Phys. Rev. 144, 1087 (1966)



Postulate particle carrying both electric and magnetic charges → **dyon**

- Quantisation of angular momentum with two dyons (q_{e1}, q_{m1}) and (q_{e2}, q_{m2}) yields:

$$q_{e1}q_{m2} - q_{e2}q_{m1} = 2n \frac{h}{\mu_0} \quad (n \text{ integer number})$$

- **Fundamental magnetic charge is now $2g_D$!**
- With $|q_e|=1/3e$ (down quark) as the fundamental electric charge, it even becomes $6g_D$

Monopole production

EM coupling constant for Dirac charge = 34.25

→ non-perturbative dynamics, no reliable cross sections and kinematics!

“Natural” benchmark models:

photon fusion

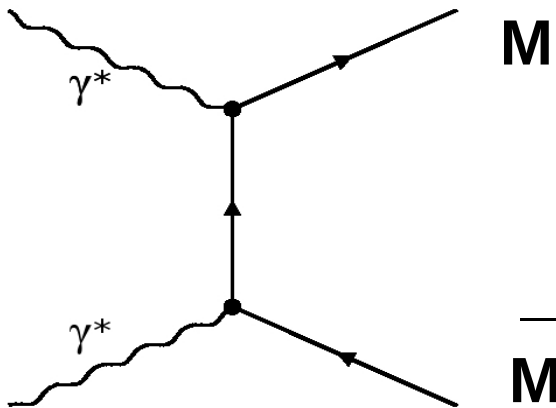

Drell-Yan

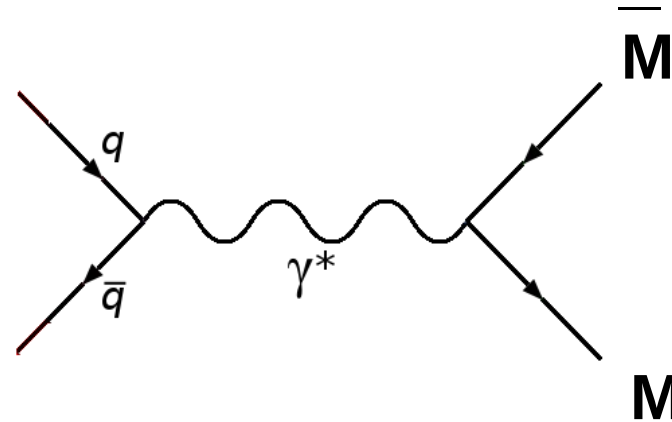

Remark: magnetic charge conservation prescribes that monopoles are **stable** and **produced in pairs**

Monopole bending

arXiv:1112.2999

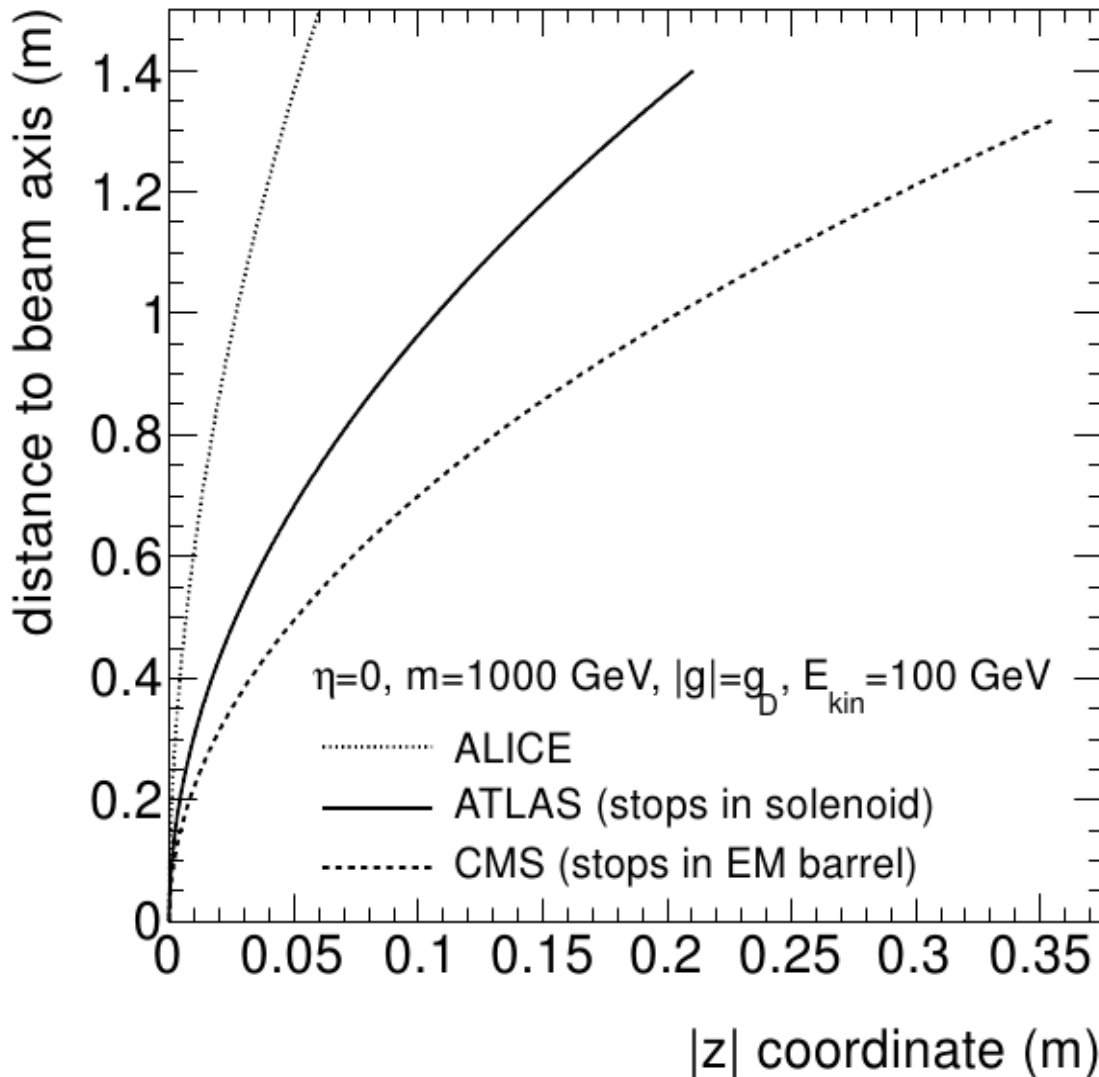

**Acceleration
along magnetic
field:**

$$F_m = q_m \cdot B$$

- Straight line in xy plane
- Parabola in rz plane

Monopole ionisation energy loss

Electric

$$-\frac{dE}{dx} = K \frac{Z}{A} \frac{z^2}{\beta^2} \left[\ln \frac{2m_e c^2 \beta^2 \gamma^2}{I} - \beta^2 \right]$$

Magnetic

$$-\frac{dE}{dx} = K \frac{Z}{A} g^2 \left[\ln \frac{2m_e c^2 \beta^2 \gamma^2}{I_m} + \frac{K(|g|)}{2} - \frac{1}{2} - B(|g|) \right]$$

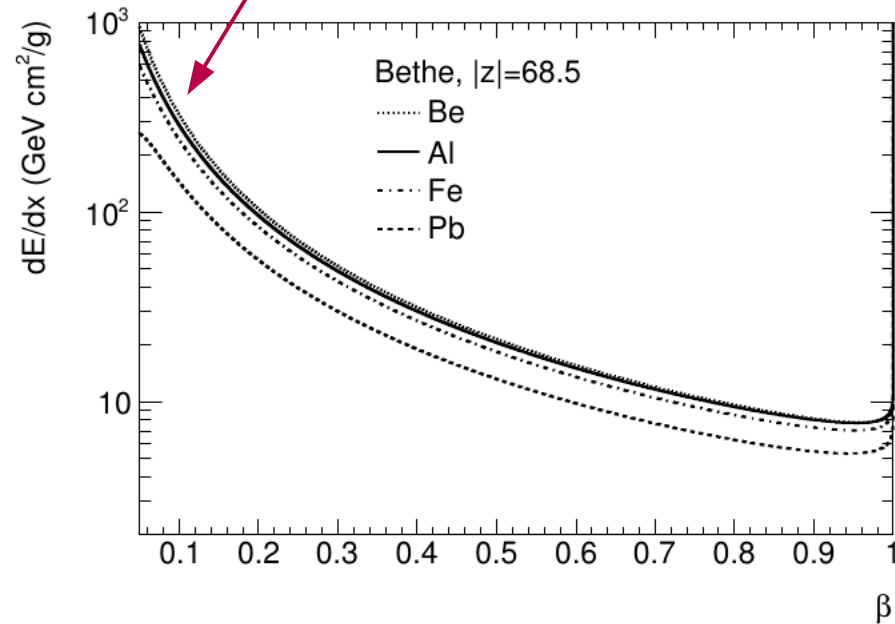

No Bragg peak!

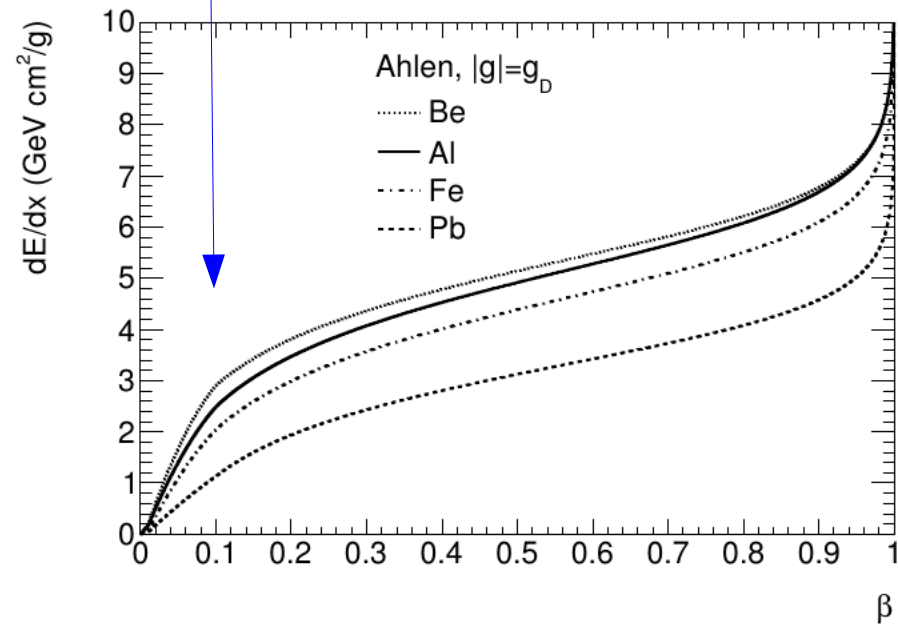

Dirac monopole: $|g_D| = 68.5 \rightarrow$ several thousand times greater dE/dx than a minimum-ionising $|z|=1$ particle

Monopole binding in matter

- **To atoms and molecules**
 - Binding energies of the order of a few eV
- **To nuclei with non-zero magnetic moments**
 - Binding energies of the order of 200 keV
- **At the surface of a ferromagnetic**
 - Image force of the order of 10 eV/\AA
 - **Robust prediction** (classical)

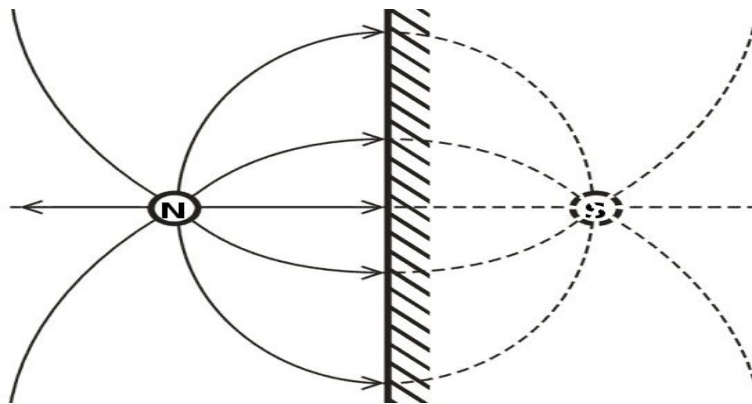

Monopole production kinematics

arXiv:1112.2999

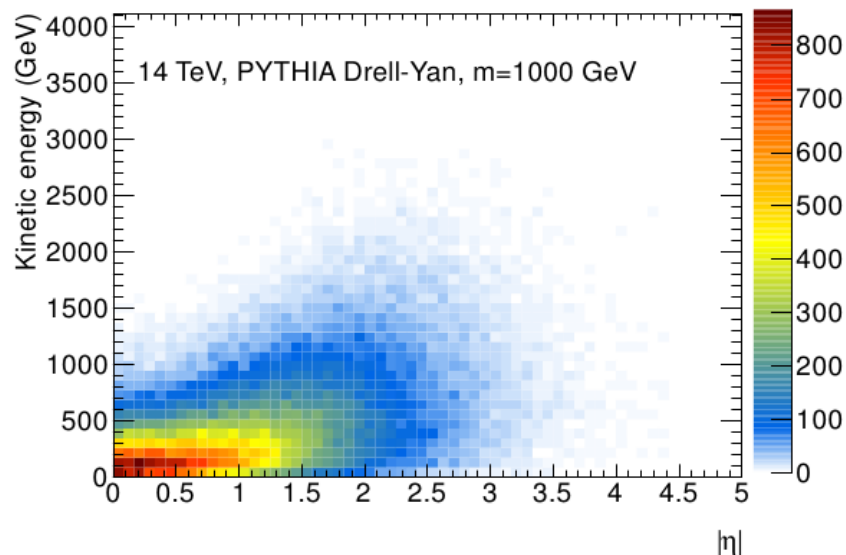
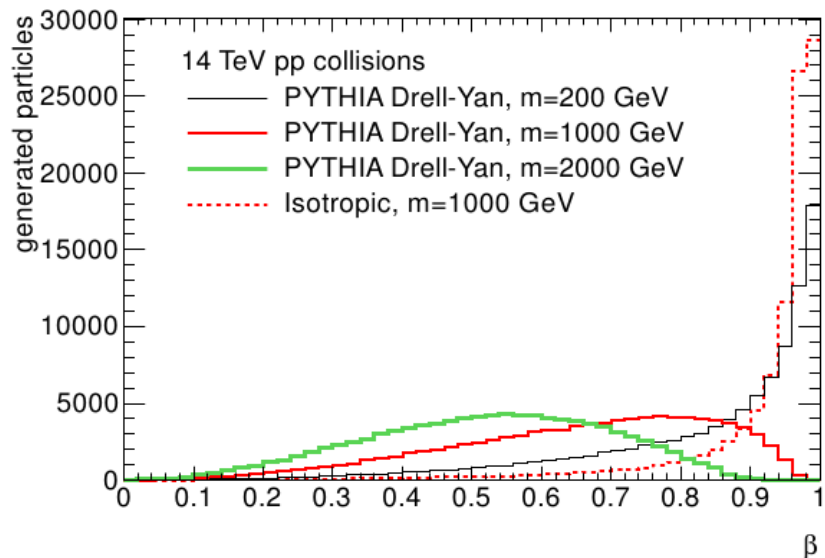
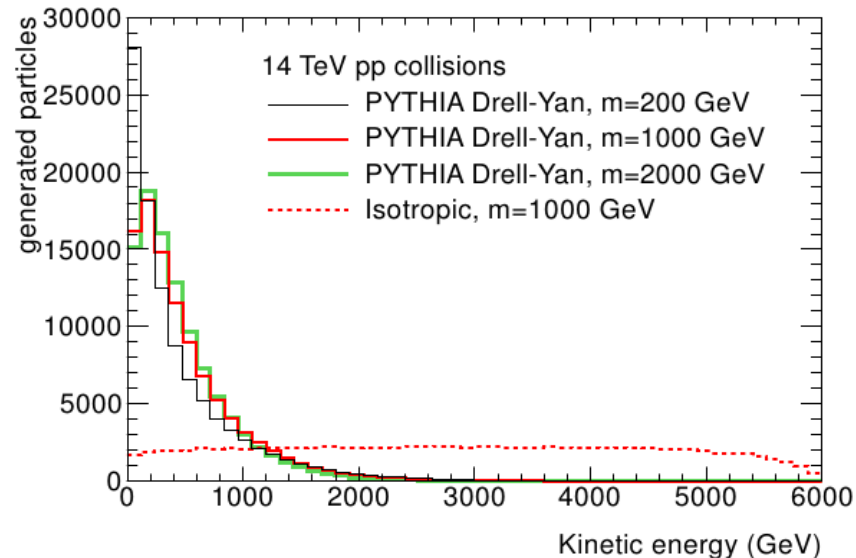
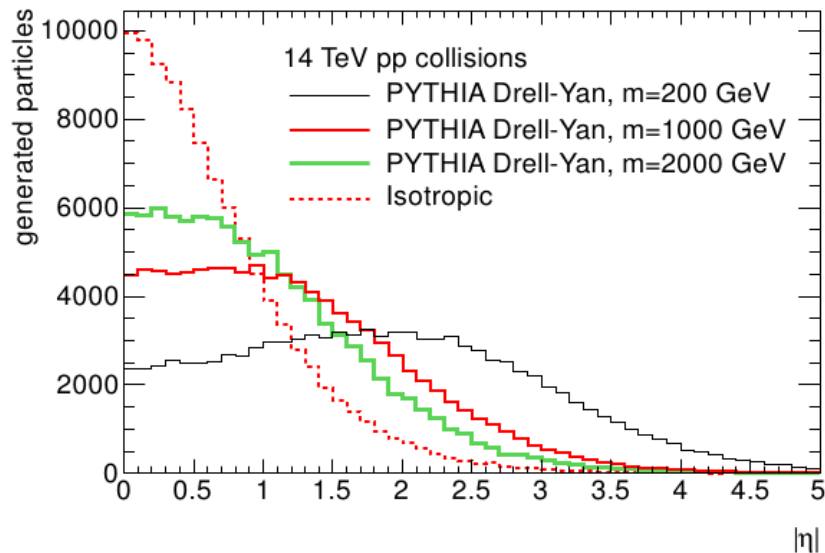

Range of monopoles in ATLAS and CMS

arXiv:1112.2999 (2012)

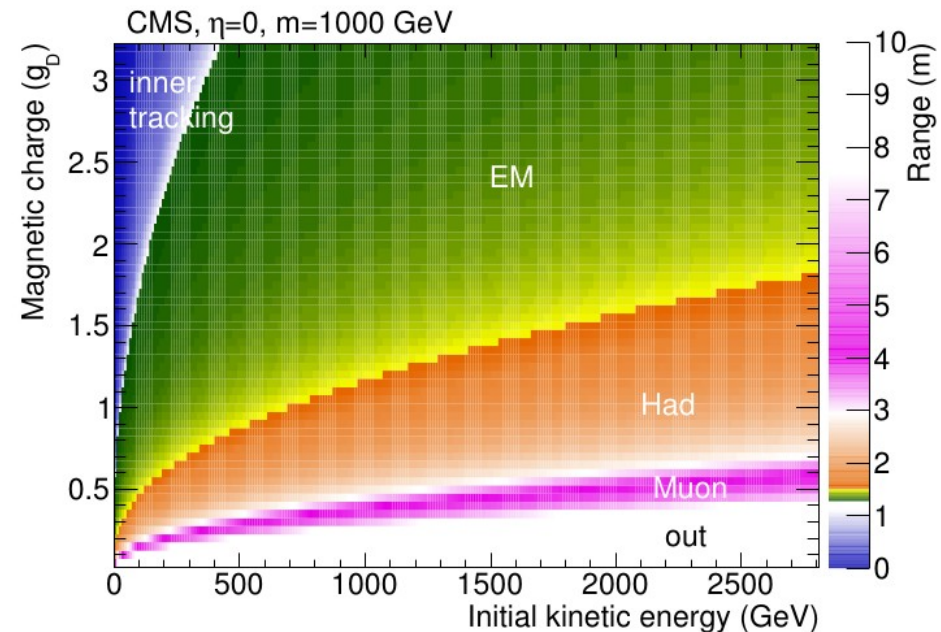
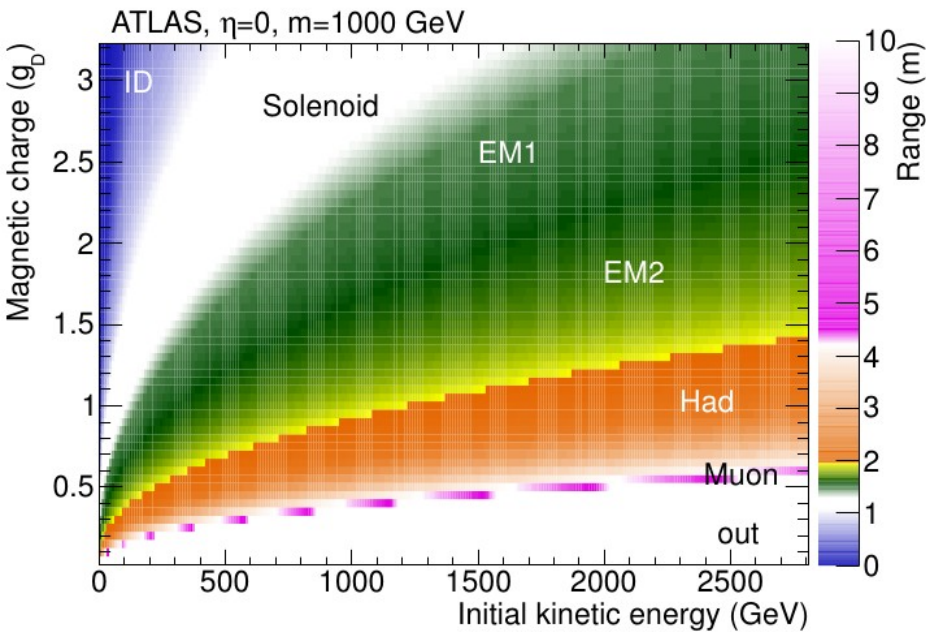

ATLAS search multiply-charged particles

First HIP search at the LHC

- Very first data (summer 2010)
- Standard EM trigger and reco
- Interpretation $6e < |q_e| < 17e$

arXiv:1102.0459 (2011)

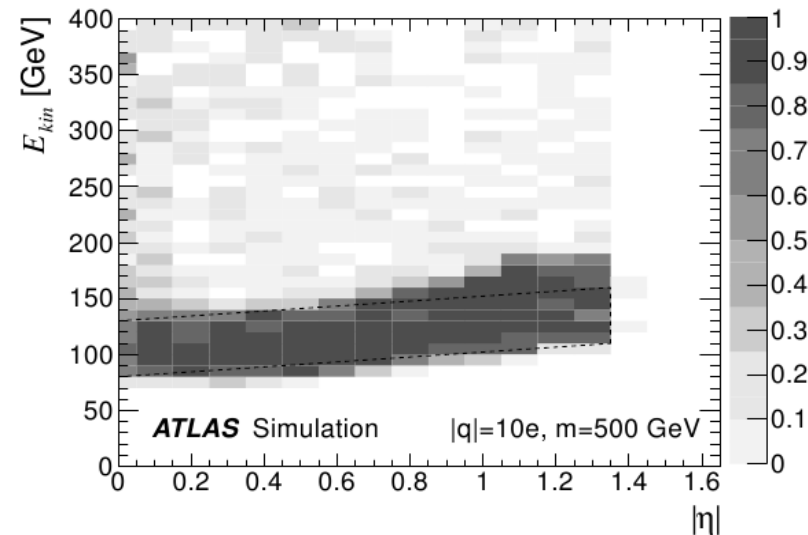
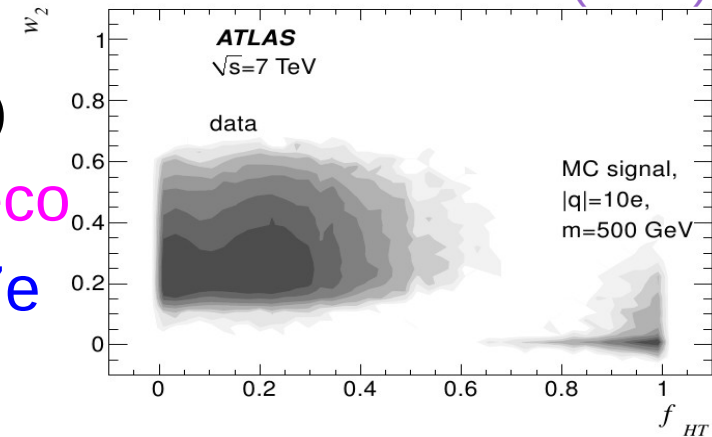

Model-independent approach:
1-2 pb limits set in well-defined kinematic ranges

ATLAS monopole search – principle

ATLAS-CONF-2012-062

- Data from 2011 (2 fb⁻¹)
- Standard EM trigger
- Special tracking
 - Count TRT hits in window around EM cluster
 - Robust against delta-electrons and anomalous bending

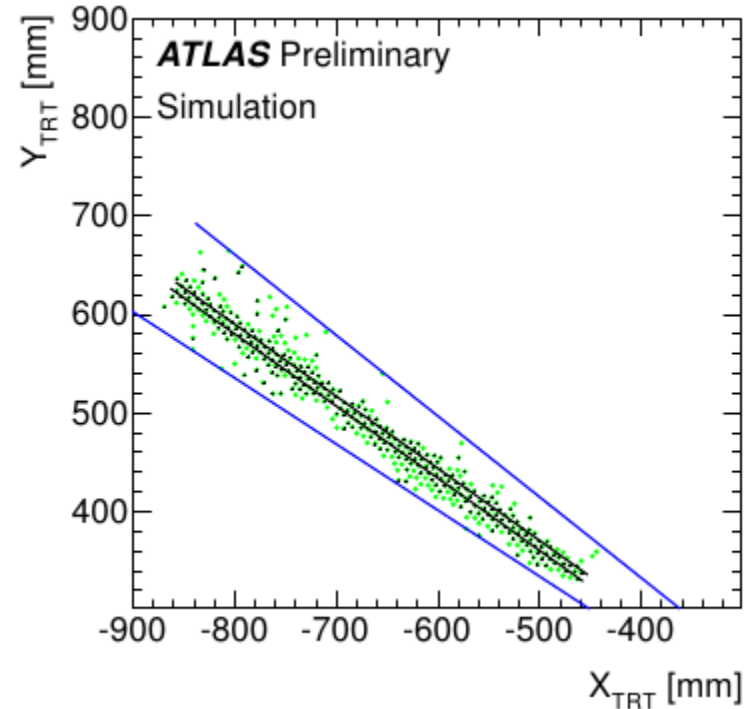

- Interpretation for magnetic monopole with minimum charge ($|g| = g_D$)
 - Applying HIP correction in LAr
 - Simulating monopole dE/dx and trajectory in Geant4

ATLAS monopole search – results

- Valid for Dirac ($n=1$) monopoles
- Blue curve is model-independent (factoring out acceptance)

PRL 109, 261803 (2012), arXiv:1207.6411

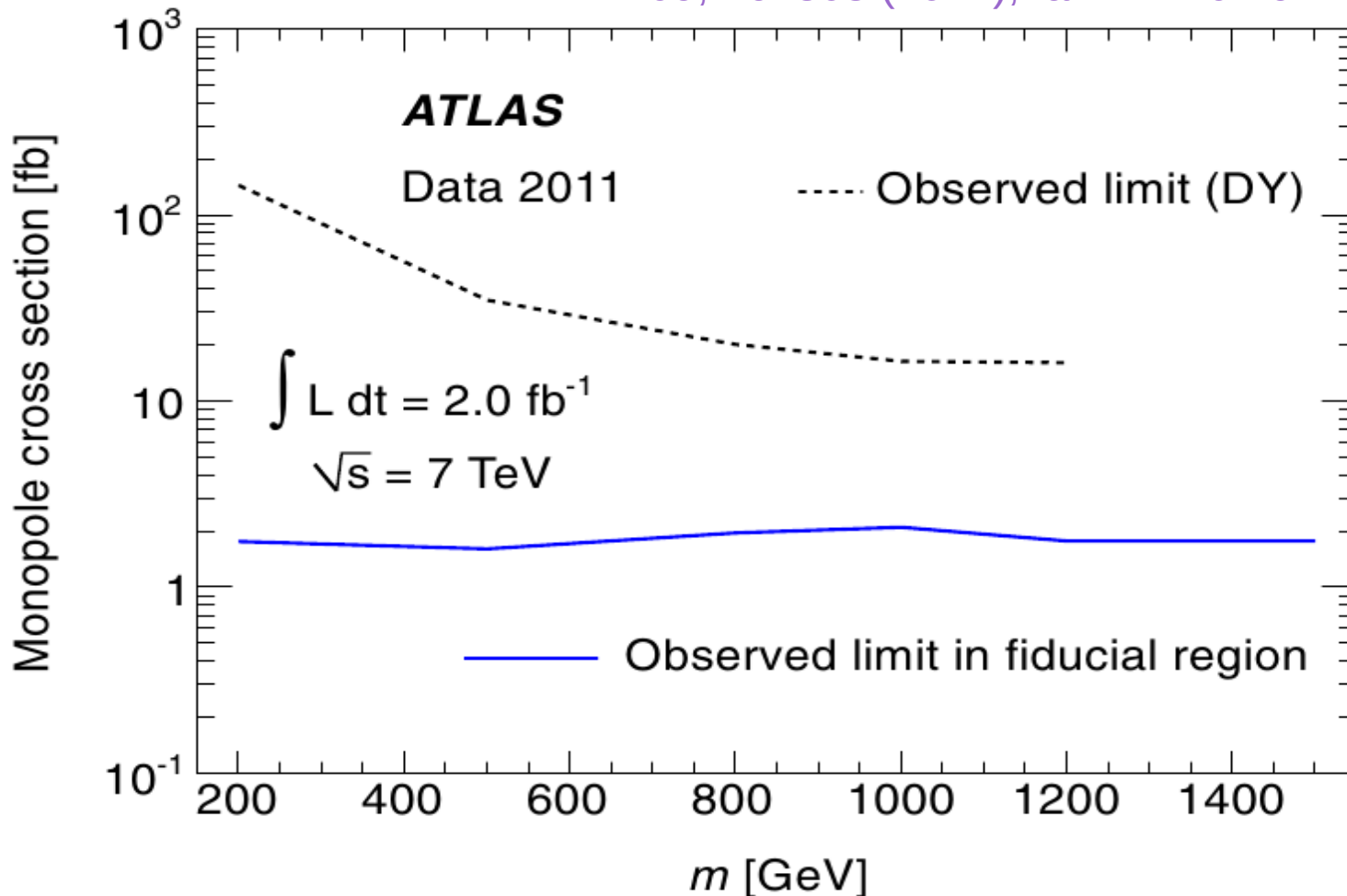

LEP1, track-etch

- Plastic detectors surrounding 15 interaction point
- 0.3 pb limit (up to 45 GeV HIPs)

Phys. Rev. D 46, R881 (1992)

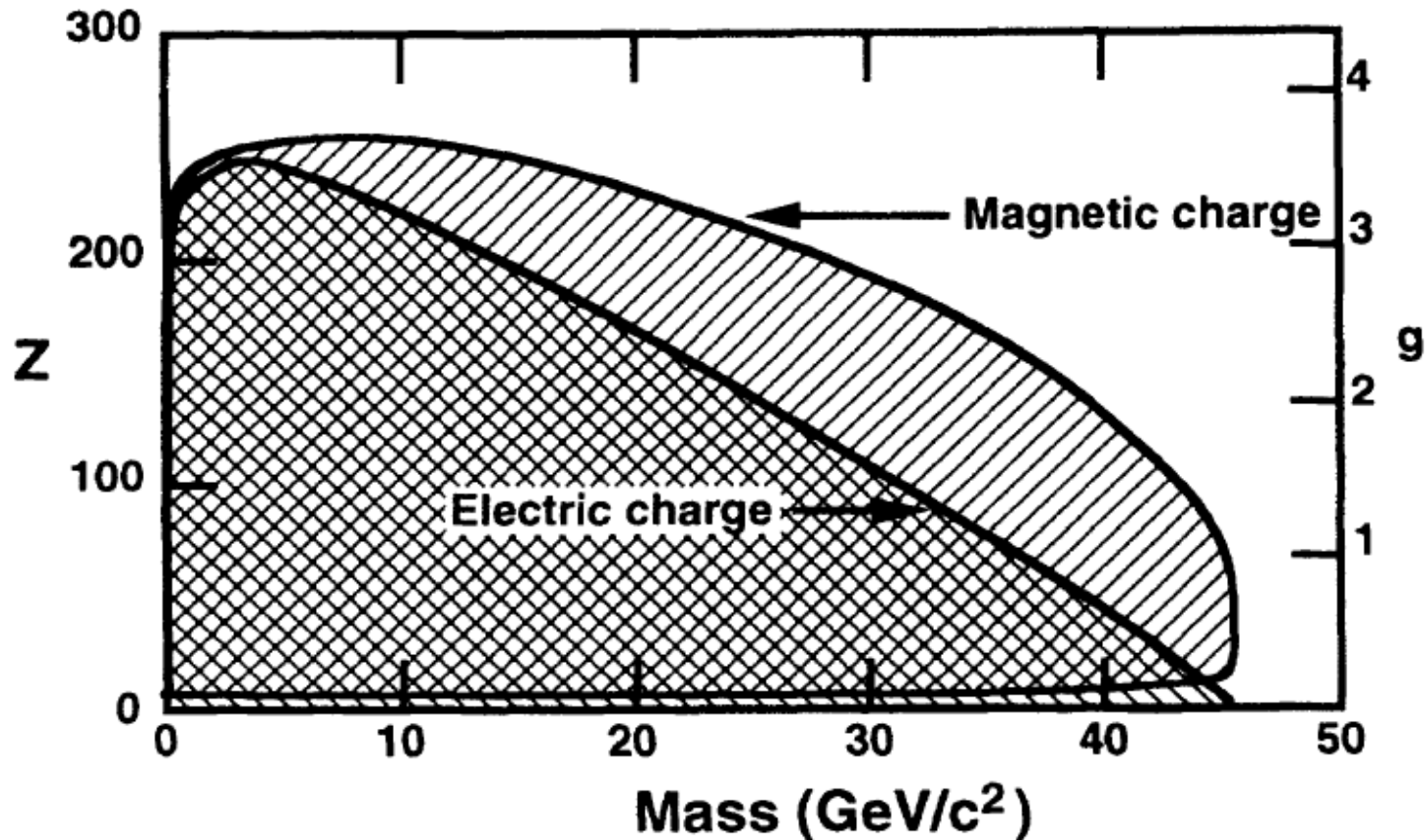

LHC reach in mass and charge

arXiv:1112.2999 (2012)

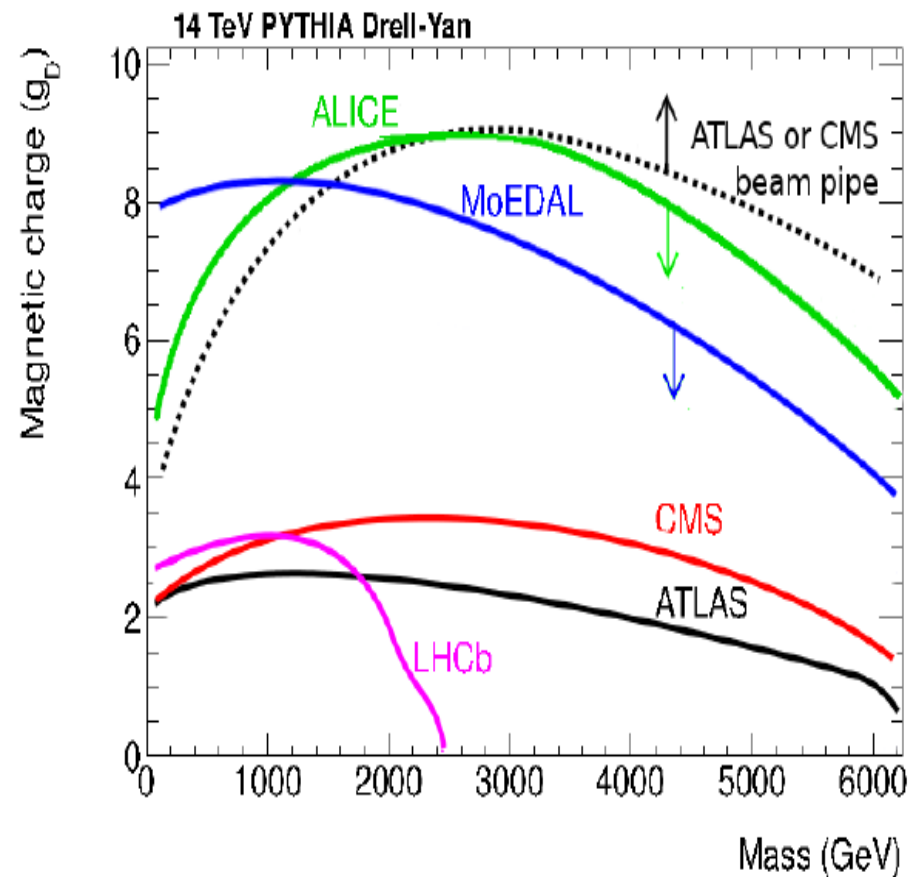
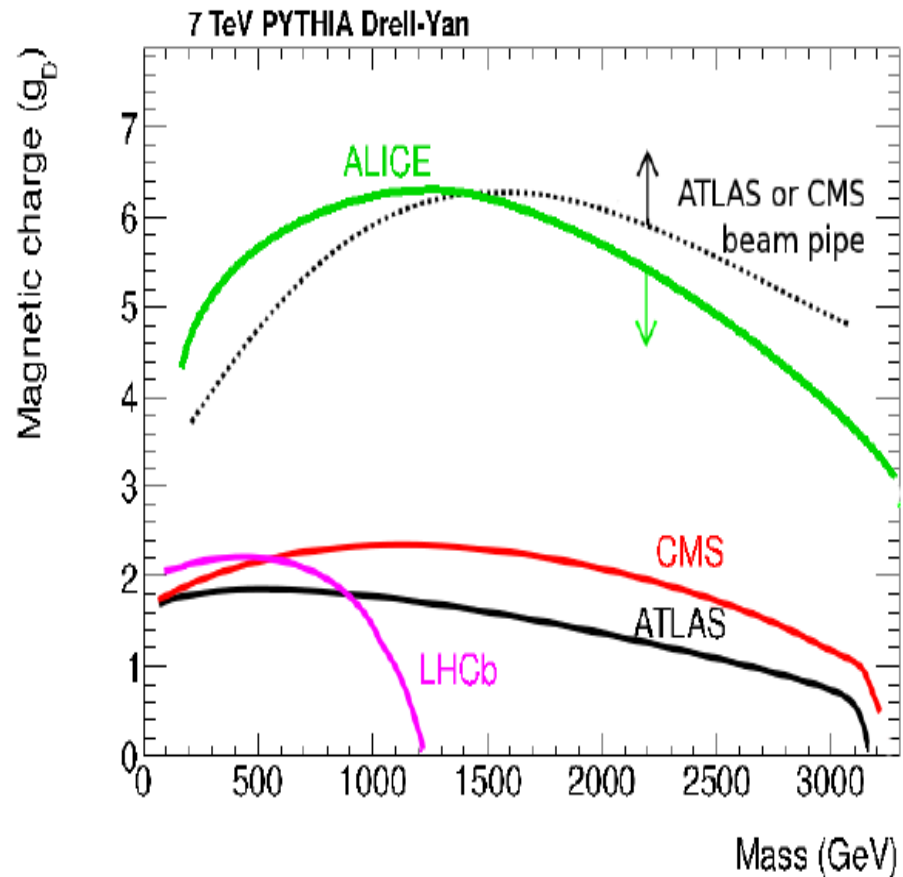

Monopoles in 100 TeV pp collisions

Contours with $>5\%$ acceptance

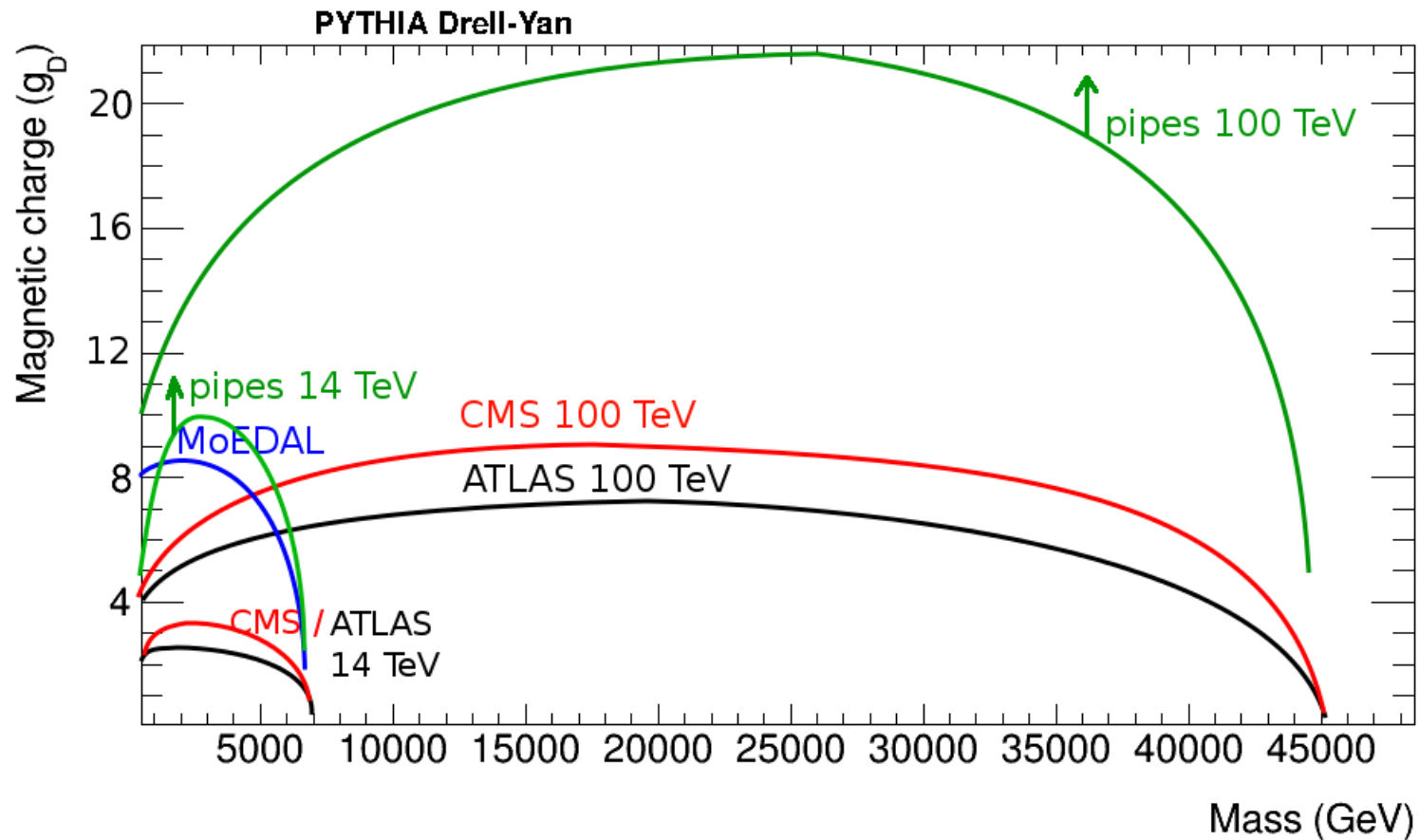

Muon anomalous magnetic moment ($g-2$)

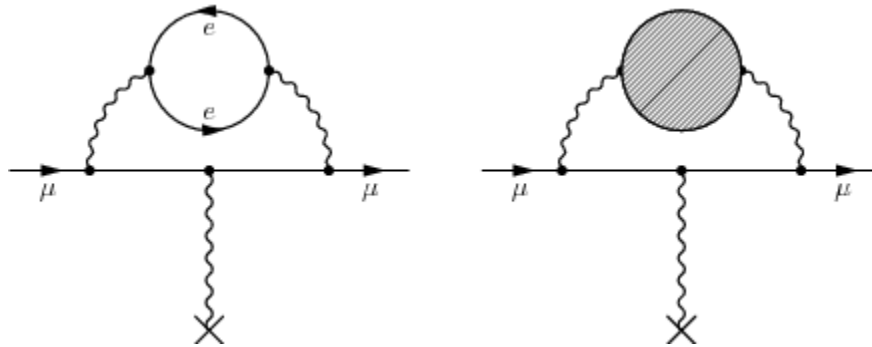

- An example of a virtual process which can hint at new physics at high energy scales
- Was used to constrain Dirac monopoles to $M > 120$ GeV (PLB 262, 463 (1991)) – no recent study to my knowledge
- Large model uncertainties on such bounds
 - Higher-order corrections in perturbative calculations
 - Assume spin-1/2, point-like monopole
- Still, the authors claim to be able to provide correct order of magnitude

Z decay to three photons

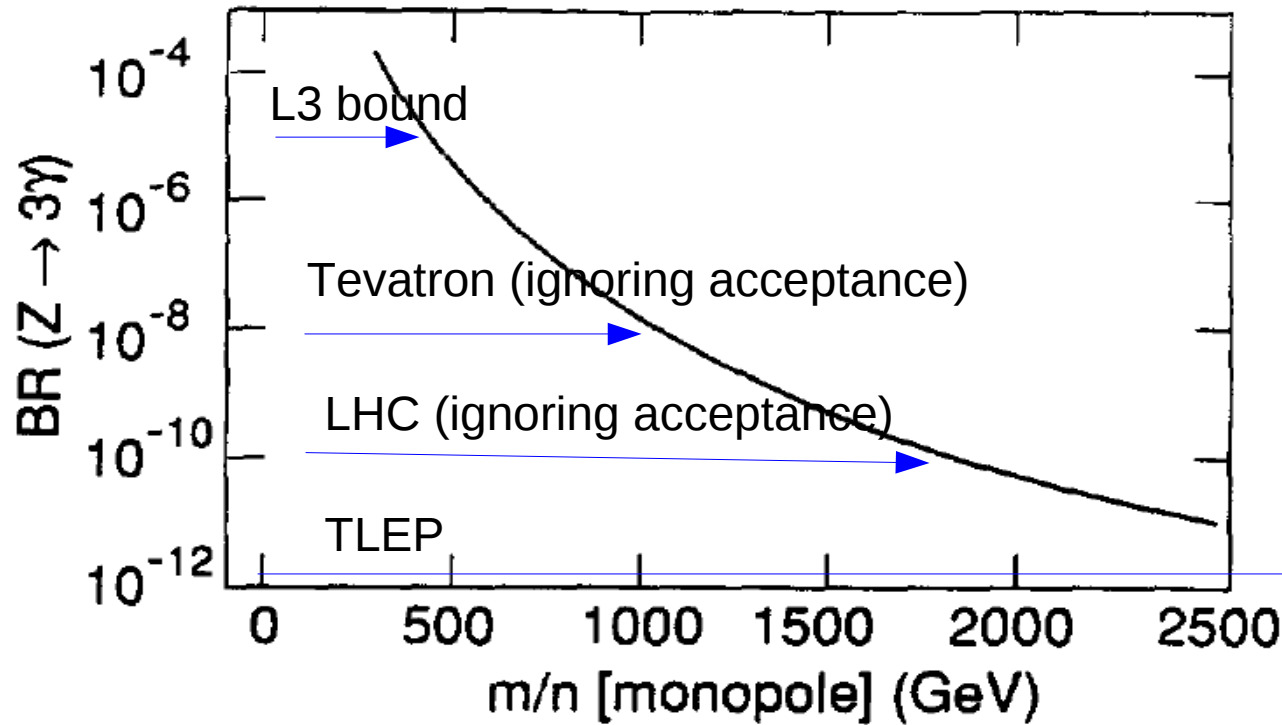
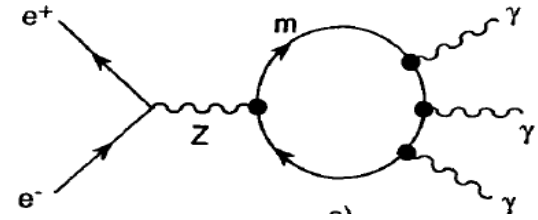

TLEP would be awesome!

H1 beam pipe (HERA, induction)

- Monopoles and dyons with very high magnetic charges would stop in the Al beam pipe!
- 0.1 – 1 pb limit (up to 140 GeV monopole with $g \geq g_D$)

arXiv:hep-ex/0501039 (2005)

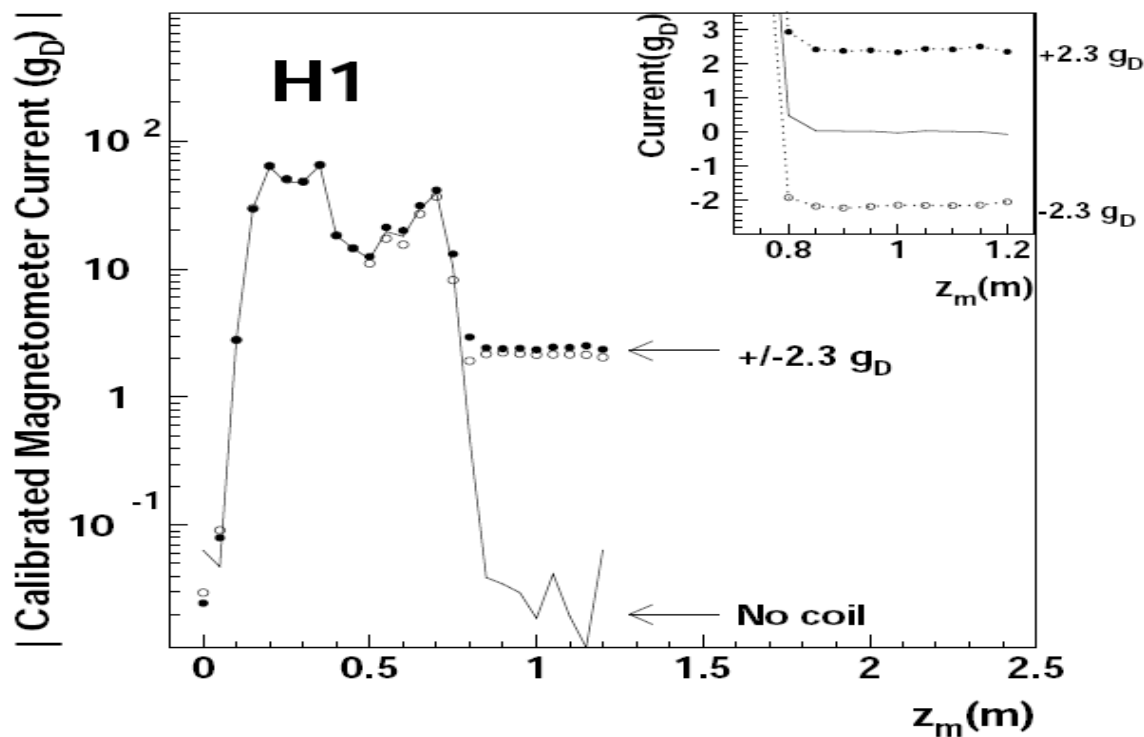

RICE (radio Cherenkov)

- Antennas buried in polar ice
 - Can identify strong radio wave signal from coherent Cherenkov radiation expected from ultra-relativistic monopole ($\beta \approx 1$)
 - “intermediate mass”
- $F < 10^{-18} \text{ cm}^{-2}\text{s}^{-1}\text{sr}^{-1}$ ($\gamma > 10^7$)

arXiv:0806.2129 (2008)

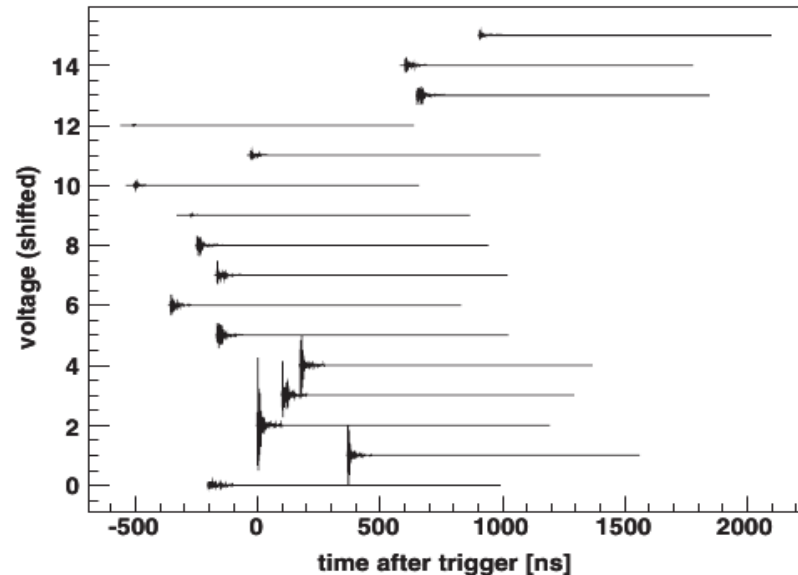
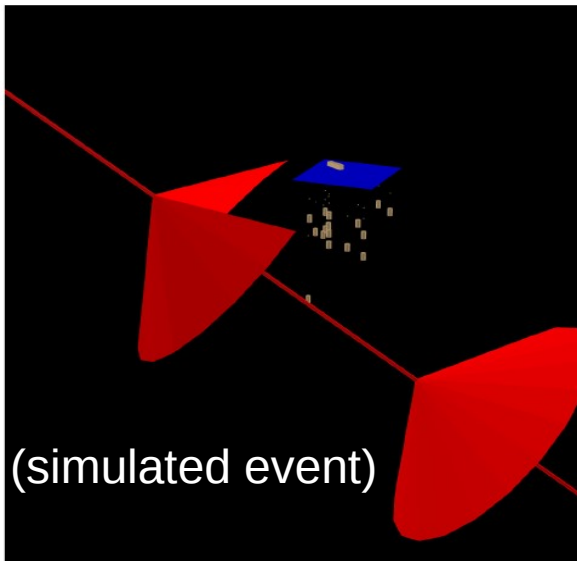

Magnetometer tests for trapped monopoles searches (1)

Laboratory of Natural Magnetism, ETH Zurich

Magnetically shielded room

DC-SQUID magnetometer



Magnetometer tests for trapped monopoles searches (2)

Proof-of-principle using accelerator material near CMS

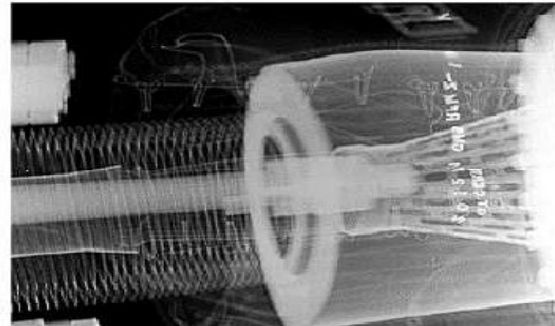
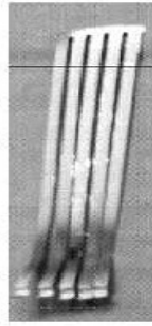
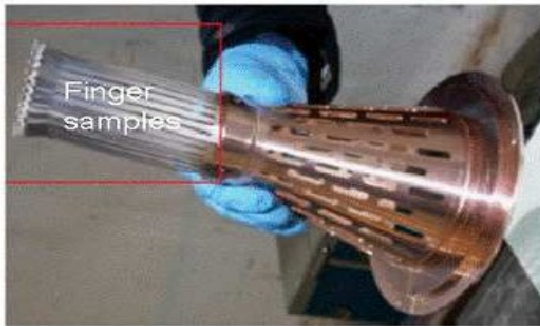

X-ray image of defective plug-in module

Calibration cross-check with long, thin solenoids

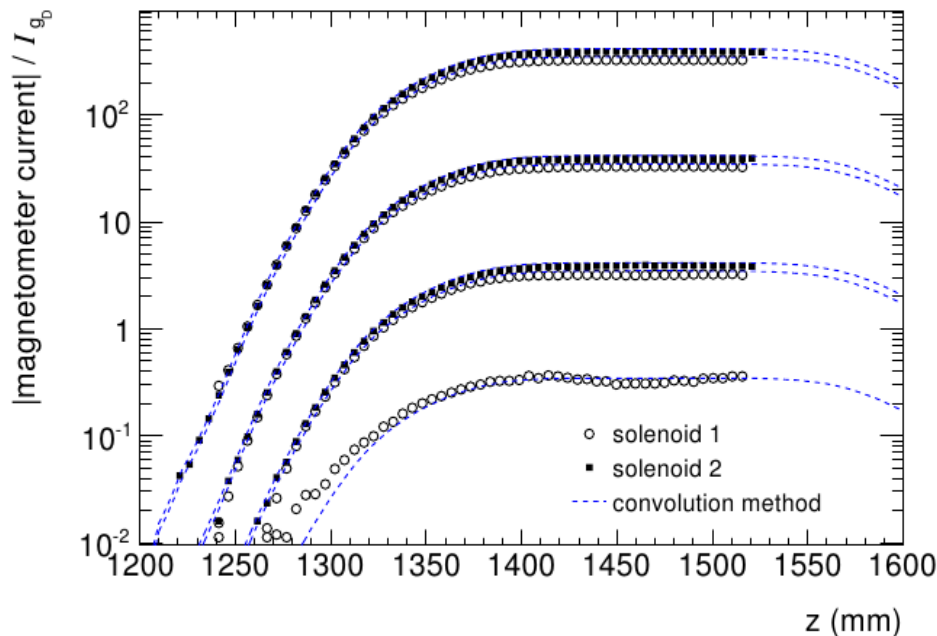

Eur. Phys. J. C 72, 2212 (2012)

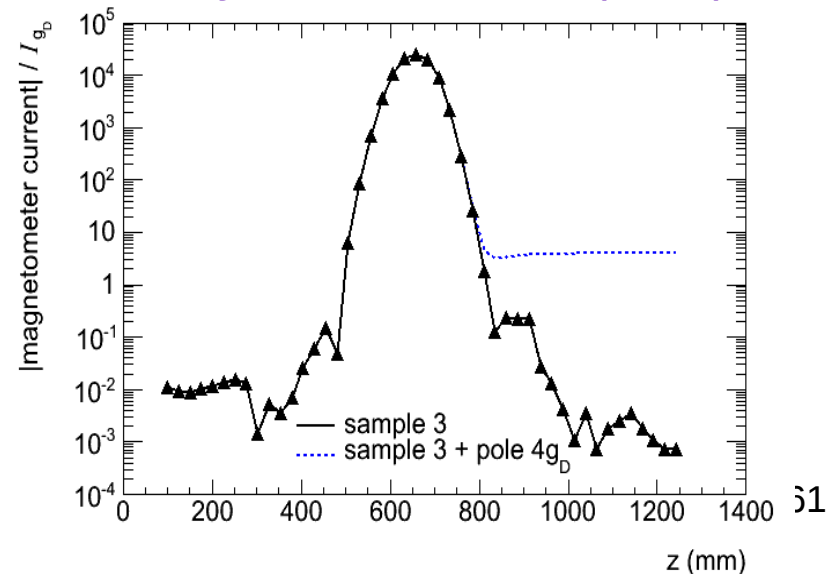

Iron ore (induction)

Superconducting coil placed under a furnace where iron ore is heated to 1300 °C

- Large amounts (>100 tons) of material
- Assume ferromagnetic binding

Must also assume no binding to nuclei!

PRD 36, 3359 (1987)

